

H. R. MOORE.
Organ-Stop Action.
No. 199,090. Patented Jan. 8, 1878.

Fig. 1.

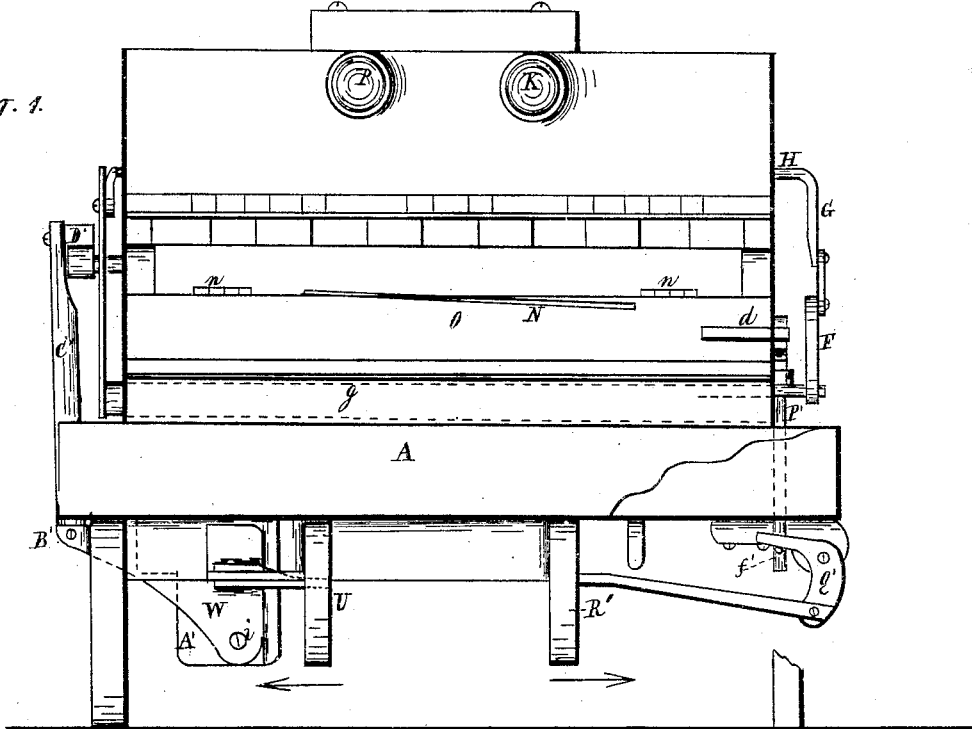
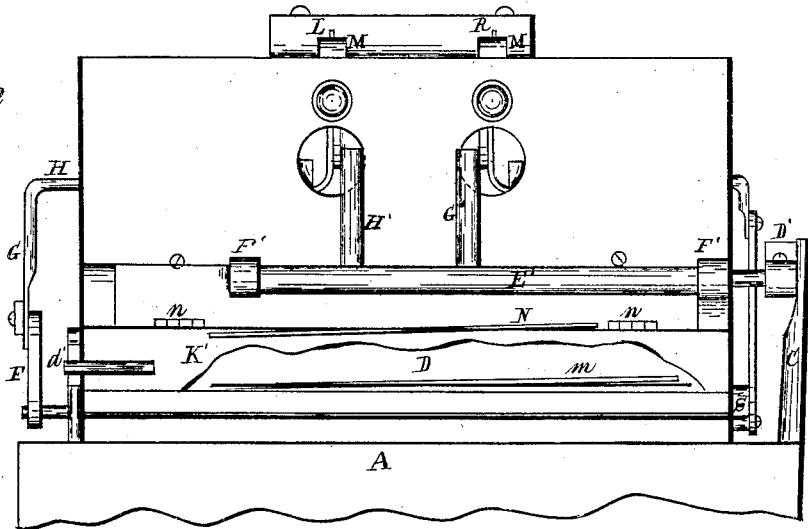

Fig 2



Witnesses.
Chas. J. Powell
W. H. Beecher

Inventor.
H. R. Moore
Per Burdick & Co
Attys.

H. R. MOORE.

Organ-Stop Action.

No. 199,090.

Patented Jan. 8, 1878.

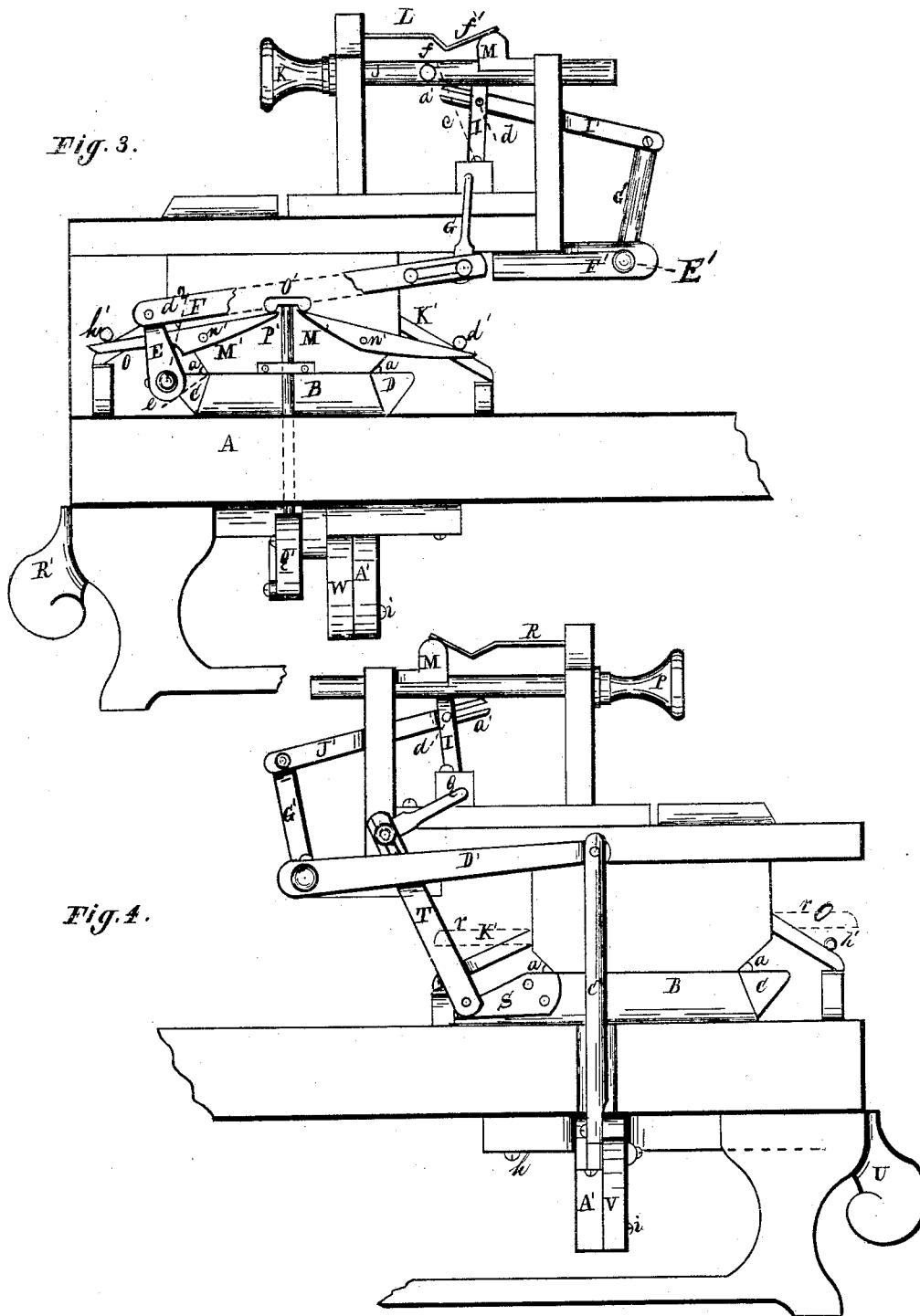

Witnesses.
 Chas. J. Powell.
 W. H. Beecher

Inventor.
 H. R. Moore
 Per Burridge & Co
 Attys.

H. R. MOORE.
Organ-Stop Action.
No. 199,090. Patented Jan. 8, 1878.

Fig. 5.

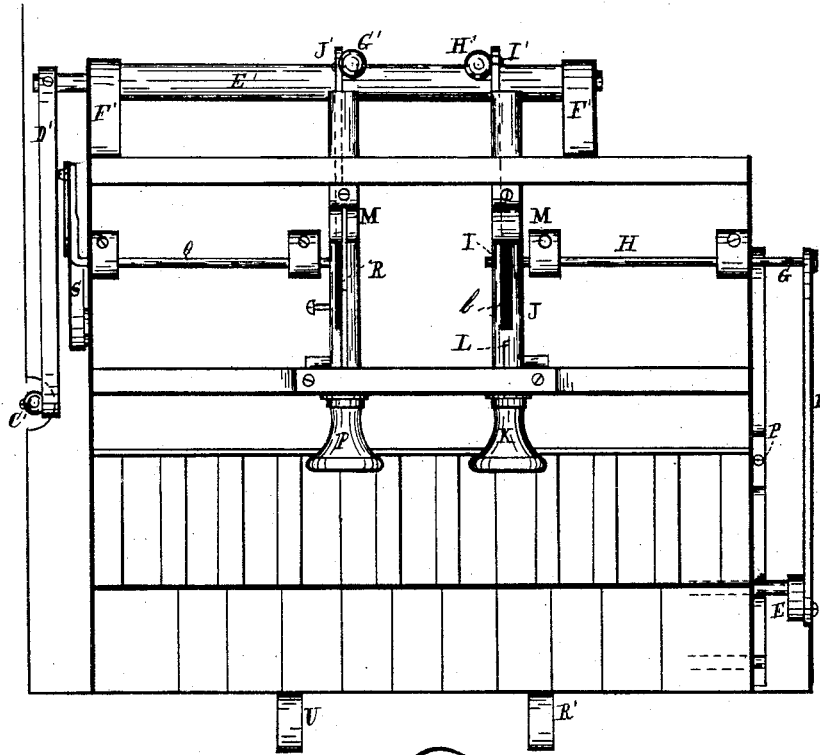
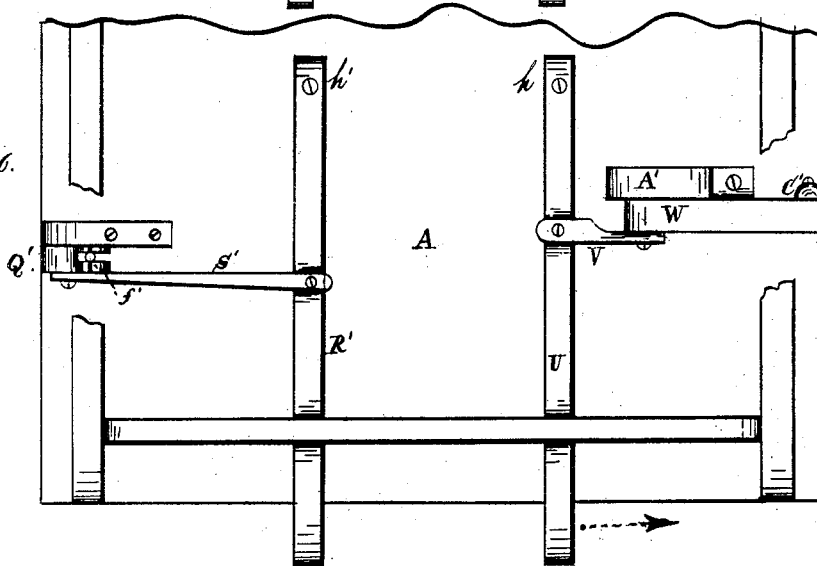

Fig. 6.



Witnesses.
Chas. J. Bowtell
W. H. Beecher

Inventor.
H. R. Moore
Per Burdick & Co
Attys.

UNITED STATES PATENT OFFICE.

HARTWELL R. MOORE, OF NORWALK, OHIO.

IMPROVEMENT IN ORGAN STOP-ACTIONS.

Specification forming part of Letters Patent No. **199,090**, dated January 8, 1878; application filed June 23, 1877.

To all whom it may concern:

Be it known that I, HARTWELL R. MOORE, of Norwalk, in the county of Huron and State of Ohio, have invented new and useful Improvements in the Mode of Operating the Mutes and Swells of Reed-Organs, of which the following is a description, reference being had to the accompanying drawings, making a part of this specification, in which—

Figure 1 is a sectional front view of an organ with the case removed. Fig. 2 is a sectional view of the back of the organ, having the case removed. Figs. 3 and 4 are sectional end views of the same. Fig. 5 is a plan view of the organ with the case removed. Fig. 6 is a sectional view of the under side of the organ.

Like letters of reference refer to like parts in the several views.

The nature of this invention relates to reed or cabinet organs, so called; and the object of the invention is to operate the swells and mutes thereof by an arrangement of levers, said levers being operated either by the hand singly or jointly by the knees, at the will of the performer, in the manner substantially as follows. So much only of the organ is shown in the drawings as will be sufficient to illustrate the application of the new to the old parts of the instrument.

In the drawings, A represents the wind-chest, on which certain parts of the organ are placed. B is the socket-board or chamber in which the reeds are arranged. Each side of the socket-board is closed by mutes C D, respectively hinged thereto at the points *a*, Figs. 3 and 4. Said mutes are opened separately or jointly, as the case may be, as follows. Separately thus: To the mute C is secured an arm, E, to which is attached a link, F, whereby it is connected to the crank G of the shaft H, Figs. 1 and 5. To the opposite end of the shaft H is an arm, I, Figs. 3 and 5. The upper end of said arm is inserted loosely in and through the draw-rod J of the knob K. A slot, *b*, is cut longitudinally in the draw-rod for its admission, as shown in Fig. 5.

By this arrangement of devices it will be obvious that on pulling forward or out the knob K the arm I will be drawn forward, as indicated by the dotted line *c*, Fig. 3. This

movement of the arm actuates the crank G and link F, which, in turn, draw back the arm E to the position indicated by the dotted line *d*, thereby lifting the mute C to the position indicated by the dotted line *e*. The mute is retained in this open position by a spring, L, Fig. 3. (Represented in Fig. 5 as broken away, in order that the slot *b* may be seen.) On pulling out the knob the lug or cam M is pulled under the elbow *f* of the spring L, whereon the free end of the spring rests. The elbow *f* in the spring falls upon the opposite side of the lug M. In this position the tension of the spring is sufficient to hold the mute open; but it will readily yield on pushing the knob partly in under the extension *f'* of the spring L. The knob will be still further pushed in automatically by the spring that closes the mute.

The inclined sides of the elbow of the spring allow it to slide readily over the top of the lug or cam on pushing the knob in or on pulling the same out. On pushing the knob in the mute is closed by a spring arranged in connection therewith, as the spring N, Fig. 1, is arranged in connection with the swell O, under which swell, and parallel therewith, the mute C is situated, as indicated by the dotted line *g*.

The mute D, arranged in the same way on the opposite side of the socket-board, is opened and closed, substantially in the same manner, by a knob, P, shaft Q, and spring R, Figs. 4 and 5, which are duplications of the knob K and other parts connected to it, above described, for opening the mute C.

To said mute D is secured an arm, S, Fig. 4, whereby it is connected to a crank of the shaft Q by the link T, all of which are substantially the same as the devices for operating the mute C, and which are manipulated by the knob P, as aforesaid.

The same arrangement can be adapted to any number of mutes.

In the event the performer requires both of the mutes C and D to be opened simultaneously, it may be done by the knee-lever U, Figs. 1 and 6. Said lever is pivoted at the point *h* to the under side of the wind-chest. To the lever is attached, by a link, V, a bell-crank, W, Figs. 1 and 3, pivoted at the point

i to a pendant, A', Fig. 1. At the end B' of said crank is attached a link, C', the upper end of which is secured to an arm, D', Fig. 1, on the end of a shaft, E', Fig. 5, having its bearings in the projectures F'.

From said shaft E' project upward arms G' and H', Figs. 2 and 5, to the upper ends of which are pivoted, respectively, the links I' and J'. The inner ends of these links are bifurcated, in which are loosely held pins *d*, whereby the arms I of the shafts H and Q are, respectively, attached, as shown in said Figs. 4 and 5.

As shown in the drawings, the pins *d d* rest against the base or bottom of the bifurcations of the links. Hence, as the links may be moved forward they necessarily carry forward with them the arms I in connection therewith.

Said forward movement is effected by the knee-lever U, above alluded to, as follows: On pushing the lever sidewise in direction of the arrow the bell-crank will draw downward the end of the arm D', to which it is connected by the link C'. This movement of the arm actuates the shaft E', thereby pushing forward the arms G' and H', together with their respective bifurcated links J' and I'. This simultaneous forward movement pushes forward the arms I, respectively, of the shafts Q and H, which, by virtue of their connection with the mutes C and D, respectively, as above described, are thereby opened at the same time without in the least disturbing the knobs P and K, whereby they are actuated separately, as hereinbefore described.

On releasing the pressure from the knee-lever the mutes will close by means of the springs attached to them, as shown at *m*, Fig. 2, in which a portion of a swell, K', is shown as broken away to show the mute D thereunder and the spring *m*, whereby it is closed, when opened, either by the knobs or by the knee-lever. The opposite mute C is arranged in the same way, and also provided with a similar spring.

Having described the manner of operating the mutes, the swells K' and O are operated substantially as follows: Said swells are hinged, respectively, to the sides of the "building up" on the socket-board, as shown at *n* in Figs. 1 and 2. From one end of each of the swells projects a pin, *d'* and *h'*, Figs. 3 and 4. To the end of said building up on the socket-board is pivoted, at *n'*, a pair of levers, M' and M'. One end of each respectively extends to and under the head O' of the rod P', Fig. 3.

To the under side of the wind-chest A referred to is pivoted a bell-crank, Q', into the bifurcated end of which the end of the rod P'

descends, and is therein secured by a pin, *f'*, Figs. 1 and 6. The lower end of said bell-crank is attached to a knee-lever, R', pivoted at *h'* to the under side of the wind-chest by a link, S', as shown in Fig. 6.

By this arrangement of devices the two swells O and K' are opened as follows: On pressing the knee-lever R' sidewise, as indicated by the arrow 2, the bell-crank will draw down the rod P', the head O of which, as a consequence, will depress the inner ends of the levers M' and M', thereby elevating their outer ends, and with them, respectively, the swells O and K', as indicated by the dotted lines *r*, Fig. 4. The swells remain thus opened so long as the knee-pressure is maintained on the knee-lever, which pressure being removed, the swells will close by the action of the springs N, Figs. 1 and 2.

The slots *b* in the draw-rods alluded to not only hold the ends of the arms I for actuating them, but the slots also serve to retain the shafts H and Q from longitudinal movement, and at the same time prevent the draw-rods from revolving. They also allow the arms I freedom to move when operating the mutes by the knee-lever.

It will be obvious that, by the above-described arrangement of devices for operating the swells and mutes of the organ, the instrument is thereby placed under complete and easy control of the performer, so that the effect of a musical composition can be fully and properly rendered, and the tones of the organ modulated, as may be desired.

What I claim as my invention, and desire to secure by Letters Patent, is—

1. The spring L, having the elbow *f* and extension *f'*, in combination with the lug or cam M on the draw-rod J, substantially as and for the purpose specified.

2. The shaft E', arms or standards H' and G', and bifurcated links I', J', and L', in combination with the arms I I, for operating jointly the mutes D and C, substantially as herein set forth.

3. In combination with the shaft E', the arm D', link C', bell-crank W, link V, and knee-lever U, all constructed and arranged to operate in the manner as and for the purpose set forth.

4. In combination with the swells K' and O, the levers *n' n'*, rod P', head O', and bifurcated bell-crank Q', constructed and arranged substantially as herein described, and for the purpose set forth.

HARTWELL R. MOORE.

Witnesses:

W. H. BURRIDGE,
J. H. BURRIDGE.