

B. F. MORRIS.  
Reversible Plow.

No. 199,093.

Patented Jan. 8, 1878.

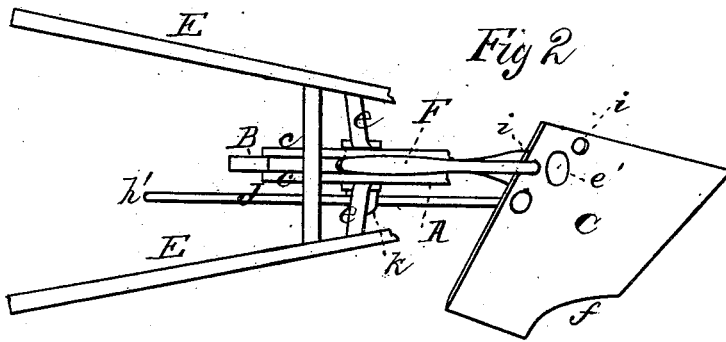
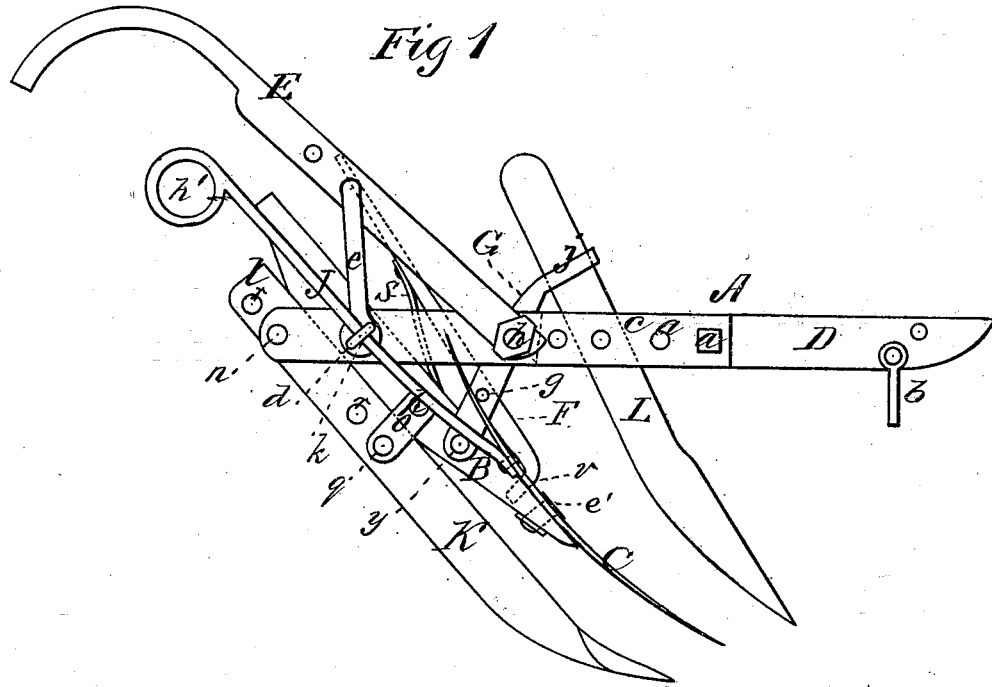

WITNESSES  
*Mary S. Utley*  
*F. J. Masi*

INVENTOR  
*Benjamin F. Morris*  
*E. W. Anderson*  
ATTORNEY

# UNITED STATES PATENT OFFICE.

BENJAMIN F. MORRIS, OF SALTILLO, ASSIGNOR OF ONE-HALF HIS RIGHT TO THOMAS F. SWIFT, OF SCOTT'S HILL, AND WILLIAM H. STRICKLAND, OF DECATUR COUNTY, TENNESSEE.

## IMPROVEMENT IN REVERSIBLE PLOWS.

Specification forming part of Letters Patent No. **199,093**, dated January 8, 1878; application filed November 3, 1877.

*To all whom it may concern:*

Be it known that I, BENJAMIN FRANKLIN MORRIS, of Saltillo, in the county of Hardin and State of Tennessee, have invented a new and valuable Improvement in Reversible Plows; and I do hereby declare that the following is a full, clear, and exact description of the construction and operation of the same, reference being had to the annexed drawings, making a part of this specification, and to the letters and figures of reference marked thereon.

Figure 1 of the drawings is a representation of a side view of my invention, and Fig. 2 is a top view thereof.

This invention has relation to improvements in that class of plows wherein the share is capable of being thrown to the right or left for the purpose of turning the sod in a corresponding direction.

The nature of the invention consists in combining, with a beam, the reversible plow, pivoted thereto, the colter, and the forked and looped brace, secured to the beam and looped over the colter, and a snap-latch, extending through and pivoted to said brace.

In the annexed drawings, the letter A designates the beam, B the standard, and C the share, of my improved plow.

The beam is composed of two spaced parallel metallic plates, *c c*, secured at their front ends, by means of bolts *a*, to a draft-bar, D, carrying on its front end the clevis *b*.

The standard B extends upward between the side plates *c c* of the beam, and is secured thereto by means of an eyebolt, *d*, extending through registering perforations in the beam and standard. This bolt also serves to secure the lower ends of two brace-rods, *e*, which connect the plow-handles E and the beam, an ordinary nut being applied to one end of the bolt for the purpose.

The plow C is lozenge-shaped and longitudinally concave, and is secured to the lower end of the beam by means of a pivot, *e'*, extending through one of the obtuse angles of the plow, the other angle opposite thereto being cut out, as shown at *f*. At each side of the pivot, and equidistant therefrom, a perfora-

tion, *i*, is made, with one or the other of which the lower end of a vertically-vibrating snap-latch, F, is engaged, according to whether the plow is right or left hand. This catch is pivoted at *g* in the forked end of an inclined brace, G, of which the lower end straddles the standard, and is secured thereto by means of a suitable bolt, *y*, and extends upward through the space between the plates *c* of the beam to the rear within easy reach of the plowman. The inclined brace aforesaid is secured to the beam by means of a bolt, *h*, extending through registering perforations in the plow-handles, the beam, and the said brace, a nut being used to clamp the said parts together, and is provided at its upper extremity with a loop, *j*, of oblong form, through which the upper end of the shank of a metallic colter, L, is passed. This colter is inclined, as shown in Fig. 1, and fits snugly in an inclined seat formed between the plates *c* by the end of the draft-bar, and a spacing-block bolted in place between the said plates.

The colter neither vibrates rearward nor to the front, and the brace will hold the standard immovable when under strain, even should the bolt *h* break.

The catch F is engaged automatically with the perforations *i* of the plow, during the reversal of the same, by means of a spring, S, secured at one end to the said latch and bearing at the other against the standard.

J represents a metallic rod, having at its rear end a handle-loop, *h'*, and pivoted at its lower end to the plow. This handle extends through the eye *k* of bolt *d* rearward within reach of the man holding the handles E.

By pressing down upon the snap-latch its down-turned end is disengaged from the plow, which may then be shifted from right to left, or the reverse, by means of the operating-rod J.

The ends of the plates *c* of the beam extend to the rear of the standard, and afford a seat between them for the shank *l* of a subsoil-plow, K, that is connected to the beam by a bolt, *n*, and its appropriate nut, and to the standard of the plows by links *o*, pivoted to each side of the said standard at *p*, and to the shank of the subsoiler by a removable through-bolt, *q*.

The shank of the plow K has two or more spaced perforations, *r*, for the reception of bolt *n*, and a like number for bolt *q*, so that the penetration of the subsoiler into the ground may be regulated at pleasure, according to the depth of the mold or surface soil. This is accomplished by shifting the bolts *n q* from an upper to a lower series of perforations, according to whether the penetration of the subsoiler is to be increased or diminished.

What I claim as new, and desire to secure by Letters Patent, is—

The combination, with the beam B, the re-

versible plow C, pivoted thereto, the colter L, and the forked and looped brace G, secured to the beam and looped over the colter, of the snap-latch F, extending through and pivoted to said brace, substantially as specified.

In testimony that I claim the above I have hereunto subscribed my name in the presence of two witnesses.

BENJAMIN FRANKLIN MORRIS.

Witnesses:

J. T. MADDOX,

M. MONTGOMERY.