

T. F. RANDOLPH.  
Ditching-Machine.

No. 199,106.

Patented Jan. 8, 1878.

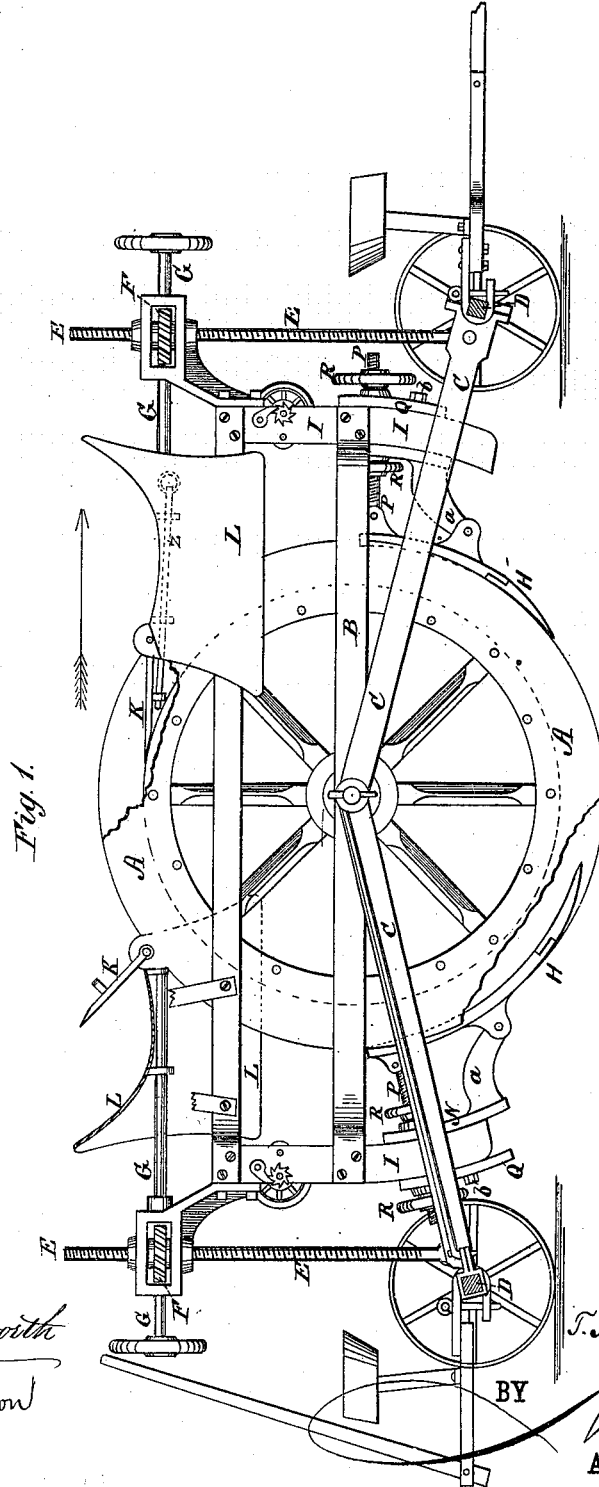

Fig. 1.

WITNESSES:

*W. W. Hollingsworth*  
*John Kemont*

INVENTOR:

*T. F. Randolph*

BY

*James L. ...*  
ATTORNEYS.

T. F. RANDOLPH.  
Ditching-Machine.

No. 199,106.

Patented Jan. 8, 1878.

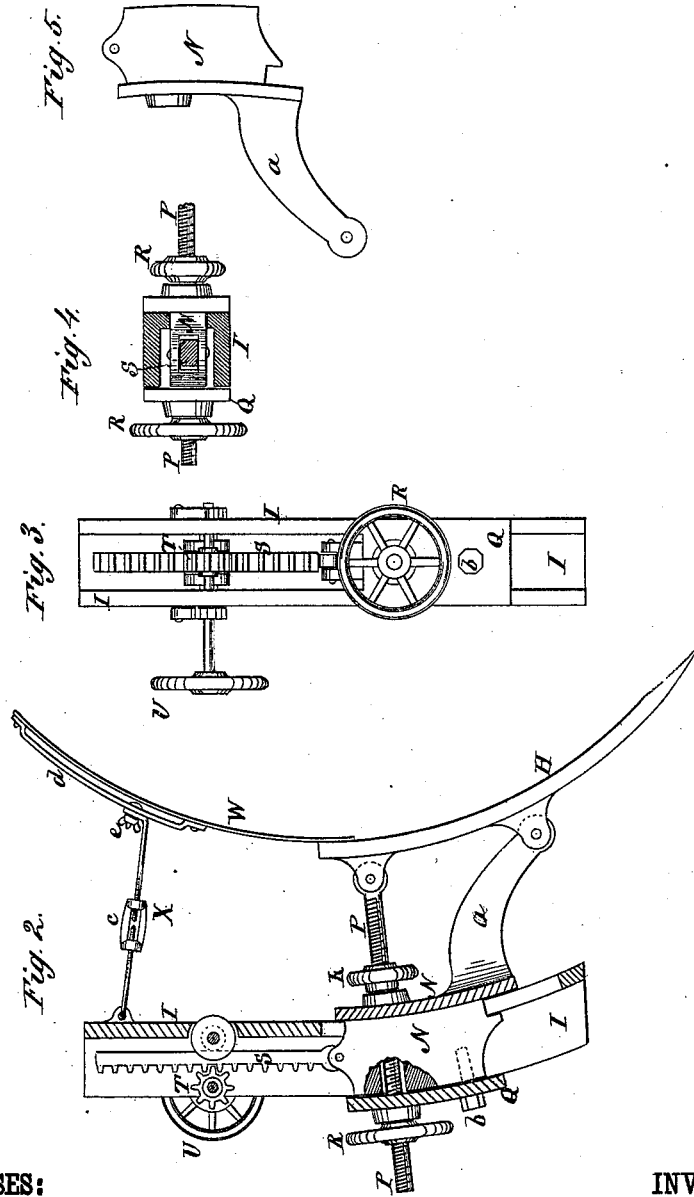

WITNESSES:  
*W. W. Hollingsworth*  
*John Kernan*

INVENTOR:  
*T. F. Randolph*  
 BY *[Signature]*  
 ATTORNEYS.

# UNITED STATES PATENT OFFICE.

THEODORE F. RANDOLPH, OF MORRISTOWN, NEW JERSEY.

## IMPROVEMENT IN DITCHING-MACHINES.

Specification forming part of Letters Patent No. **199,106**, dated January 8, 1878; application filed December 17, 1877.

*To all whom it may concern:*

Be it known that I, THEODORE F. RANDOLPH, of Morristown, in the county of Morris and State of New Jersey, have invented a new and useful Improvement in Ditching-Machines; and I do hereby declare that the following is a full, clear, and exact description of the same.

My present invention is an improvement upon the machine for which I have received Letters Patent No. 159,118, dated January 26, 1875. That machine, like others of its class, requires to be reversed or turned about at the end of the cut or excavation made by it, which involves a great loss of time and labor.

To avoid this I first attempted to simply duplicate the curved spade or shoe and its adjusting mechanism on each side of the channeled soil-cutting or ditching wheel. In other words, I employed such spade and its connected mechanism at each end of the machine with a view to adapting the latter to work with either end forward; but, upon practical trial, it was found that the construction of the spade or shoe and the connected parts constituting the adjusting mechanism shown and described in my aforesaid patent could not be duplicated in the same machine with the desired and expected successful result, owing to the fact that, whichever duplicate mechanism was idle, it could not be raised and held out of the way, so as to leave the other parts of the machine free to operate in the required manner. After various unsuccessful attempts to overcome this difficulty—namely, to change the construction of the aforesaid machine to enable the idle spade or shoe and its connected parts to be adjusted out of the way—I devised the present improvement, which has fully met all practical requirements.

I will now proceed to describe the same, reference being had to the accompanying drawing, (two sheets,) in which—

Figure 1 is a side elevation of the machine, with some parts in section. Fig. 2 is a partly-sectional elevation of the channeled guide-post and spade and the mechanism for adjusting and clamping the latter. Fig. 3 is an end elevation of the post and part of the spade-adjusting mechanism. Fig. 4 is a cross-section on line *x x*, Fig. 3. Fig. 5 is a detail view

of the block or holder to which the spade is hinged.

The flanged or channeled ditching-wheel A has its bearings in the fixed frame B, and bars C C connect its journals and the duplicate axles D D, as in my prior machine. The said wheel is likewise adjusted vertically by substantially the same means—namely, vertical screws E E, pinions F F, and a horizontal worm-shaft, G.

At either end of the ditching-wheel I provide a shoe or spade, H, and devices for adjusting and clamping it in any required position; also, a curved guide-post, I, to which the spade and the adjusting and clamping mechanism are attached. I also employ two tongues, K K, on the upper side of the wheel, which are hinged to duplicate double or saddle-shaped chutes L L, for removing the soil from the wheel-channel and discharging it on each side of the machine.

Each spade H is hinged, at or near its middle, to the arm *a* of a rabbeted or T-shaped block, N, which slides on the grooved or slotted guide-post I. A cap-plate, Q, is applied on the outer side of the post, and secured to the block by means of a bolt, *b*. A screw, P, is pivoted to the upper end of the spade, and passes through said block and cap-plate, as clearly shown in Fig. 2. A wheel-nut, R, is applied to the screw on each side of the post, one working in frictional contact with the face of the block, and the other with the cap-plate. These nuts serve to adjust the screw longitudinally, and thereby change the angle of the spade to cause it to take a thin or thick slice of soil, and, when screwed tightly against the block and cap-plate, they (in connection with a rack and ratchet mechanism hereinafter described) hold the spade very rigidly in any adjustment.

For these purposes—namely, adjusting and clamping or holding the spade—I have found this construction and arrangement of parts superior to that shown in my aforesaid patent.

The means for adjusting the block N and spade H vertically are the rack-bar S and pinion T, Fig. 2, the latter being operated by a hand-wheel, U, fixed on the pinion-shaft. The rack-bar is hinged to the block N, to allow the latter to follow the curve of the post I. This

mechanism enables the spade to be adjusted higher or lower with ease, rapidity, and accuracy. The object and function of the curved form of guide-post are twofold: first, it enables the spade, with its holder or block, to be easily and readily hoisted away from the ditching-wheel when the action of the latter is to be reversed, and the theretofore idle spade is to be put into active work. As the flanges of the ditching-wheel opposite the spade last in active work are usually filled with earth at the moment of stopping work, it will be seen that, if the spade were raised in a vertical line, it would, owing mainly to its curved form, come in contact with and press against the earth still held in the wheel, so that the adjustment of the active spade into its idle position would be difficult; second, it enables the idle spade, when lowered to the required point or place, to assume the proper angle for cutting, without requiring readjustment by means of the screw.

The tail-piece or extension W of the spade is a curved spring-plate; and, to prevent the same yielding to the outward pressure of the soil packed in the wheel-channel, I employ a set-rod, X, composed of two parts connected by an adjusting-nut, e, which enables the length of the rod to be practically increased, as required, by the vertical adjustment of the spade. The rod is connected with the tail-piece by a slotted guide, d, and T-headed clamp-screw e, as shown.

When the machine advances in either direction, the tongue K hinged to the chute which is nearest what will then be the forward end of the machine is fixed between the flanges of the ditching-wheel, while the other tongue K is raised and thrown back out of the way. (These relative positions of the tongues are illustrated in Fig. 1, in which the arrow indicates the direction of movement of the machine.) The tongue K, which is horizontal, is held in such position by means of a bolt, Z, which is inserted in guide-sockets beneath the double chute L, and passes through a perforated lug formed on the under side of the tongue. When it is desired to raise one of the tongues, its locking-bolt is drawn back to free it from the perforated lug.

It will be readily understood that when the machine advances the ditching-wheel A rotates and cuts the sides of the soil-slice, which the curved spade H then severs from its bed. The soil-slice is carried and pushed upward in the space between the wheel and the spade and its extension or tail-piece W, and, passing

over the horizontal tongue K on the upper side of the wheel, is discharged at pleasure on one or both sides of the machine by the forward double chute L. When the machine has cut a given distance, and the return work is to be performed, the power is attached to the other end of the same. The spade which made the last cut is then raised out of the way, and the one previously idle is lowered and clamped in position for work. The ditching-wheel is then lowered so as to rest with its periphery on the earth forming the bed of the incomplete ditch. These adjustments are quickly effected, and the machine is then ready to make a return cut in the same place, or along the same line, for the deepening of the ditch. And thus the machine continues to work in either direction until the ditch has been cut to the required depth.

The saving of time effected by avoiding reversing the machine or turning it about at the end of each cut is more than fifty per cent., so that more than double the amount of work may be done with it than with those machines which are adapted to run in but one direction.

What I claim is—

1. In a ditching-machine, the combination of the curved guide-post, the circularly-adjustable spade, the block to which the latter is hinged or pivoted, and the ditching-wheel, as shown and described, for the purpose specified.

2. In a ditching-machine, the combination of the hinged rack-bar, the pinion meshing therewith, and the block N, the spade and the channeled guide-post, as shown and described.

3. In a ditching-machine, the hinged spade, the adjusting-screw pivoted thereto, the block or holder N, the adjusting and set nuts, and the guide-post provided with a slot at its lower end, all combined and arranged as shown and described.

4. In a ditching-machine, the combination, with the ditching-wheel, of the hinged tongue, having a perforated lug on its under side, and the locking-bolt, adapted to slide in guide-sockets beneath the chute, as shown and described.

5. In a ditching-machine, the combination of the two-part adjusting-rod with the extension or tail-piece of the spade, as and for the purpose specified.

The above specification of my invention signed by me this 14th day of December, 1877.

THEO. F. RANDOLPH.

Witnesses:

SOLON C. KEMON,  
CHAS. A. PETTIT.