

M. L. DEERING.
Machine for Painting Barrels.
No. 199,623. Patented Jan. 29, 1878.

Fig. 1.

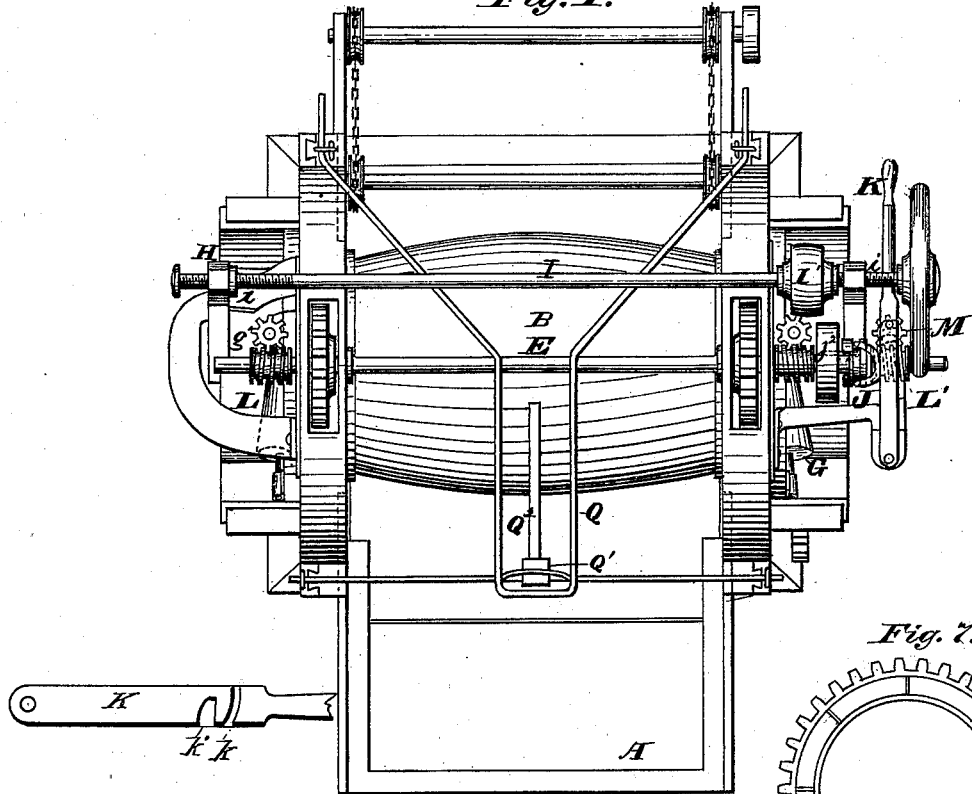

Fig. 7.

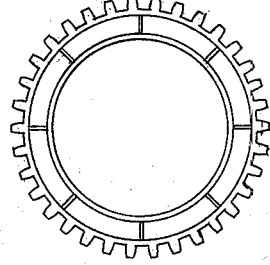
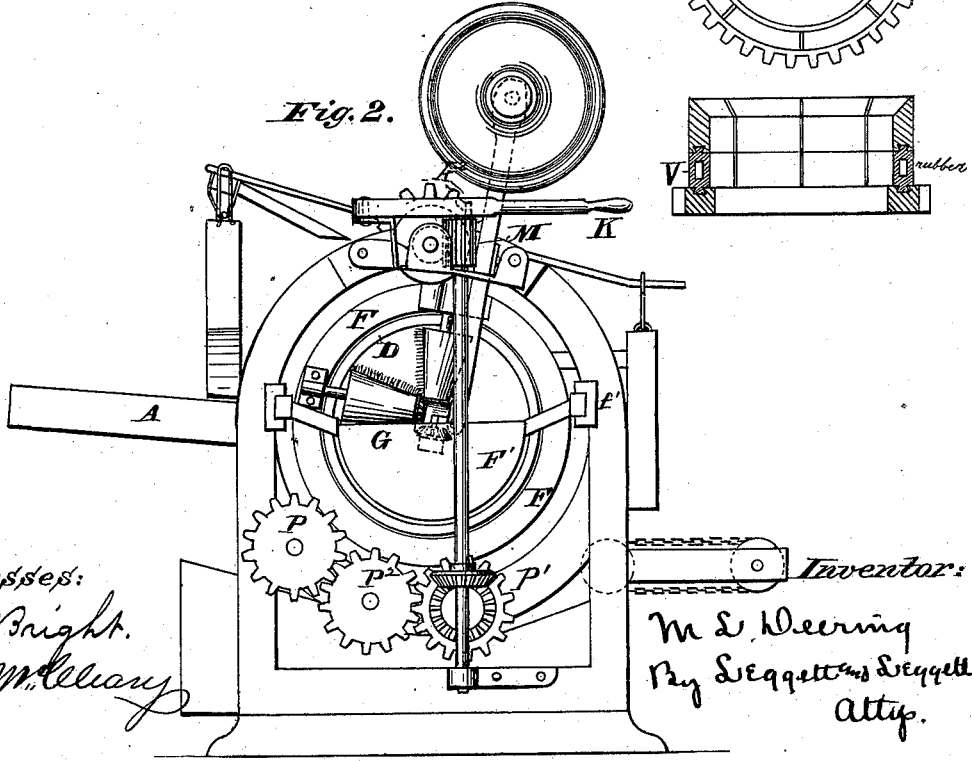

Fig. 2.



Witnesses:
A. Wright.
G. M. Kelley

Inventor:
M. L. Deering
By Sequester & Sequester
Attys.

M. L. DEERING.
Machine for Painting Barrels.
No. 199,623. Patented Jan. 29, 1878.

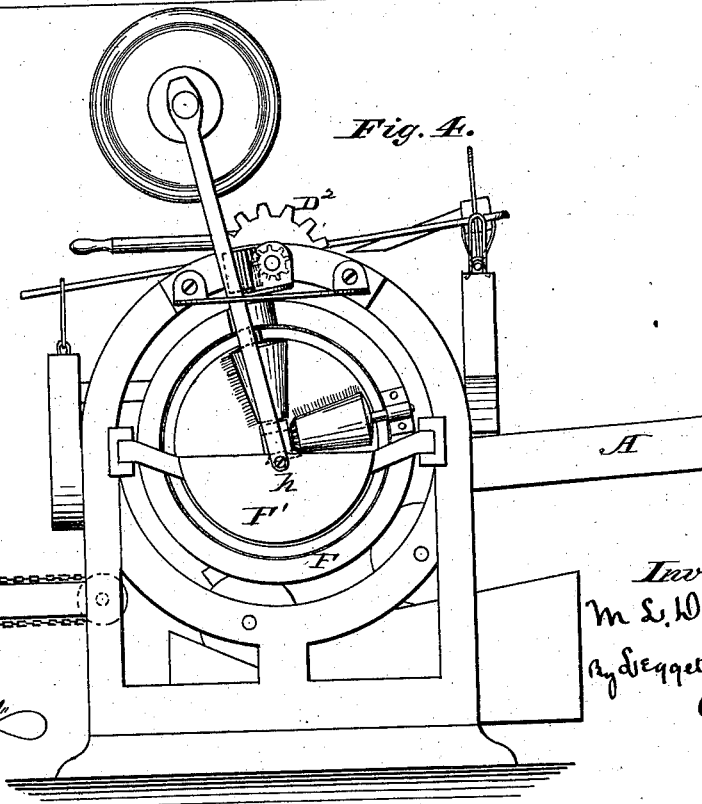
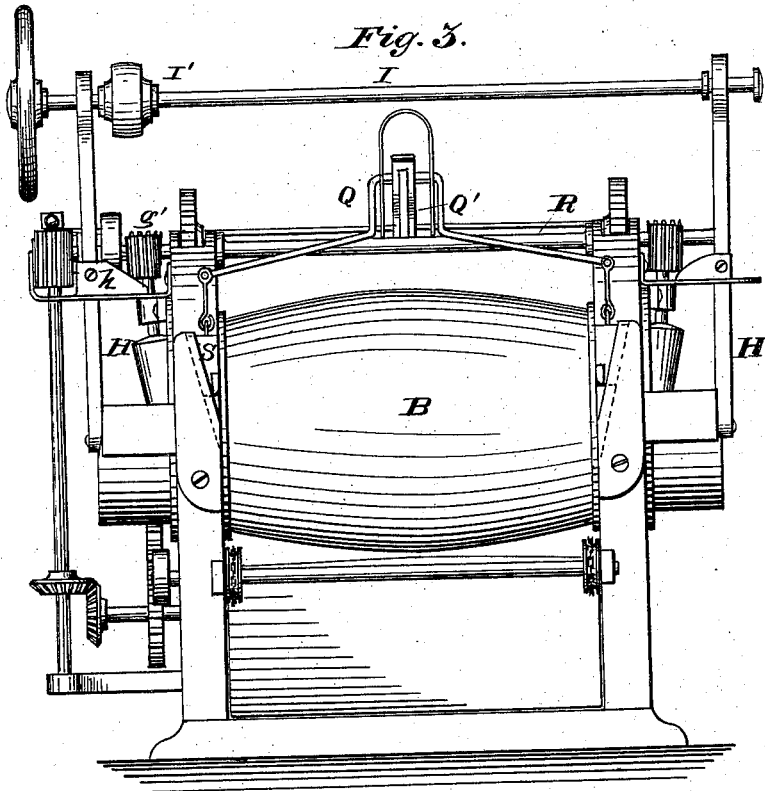

Witnesses:
A. N. Bright.
A. O. W. Cleary

Inventor:
M. L. Deering.
By Degett & Degett
Atty.

M. L. DEERING.
Machine for Painting Barrels.
No. 199,623. Patented Jan. 29, 1878.

Fig. 5.

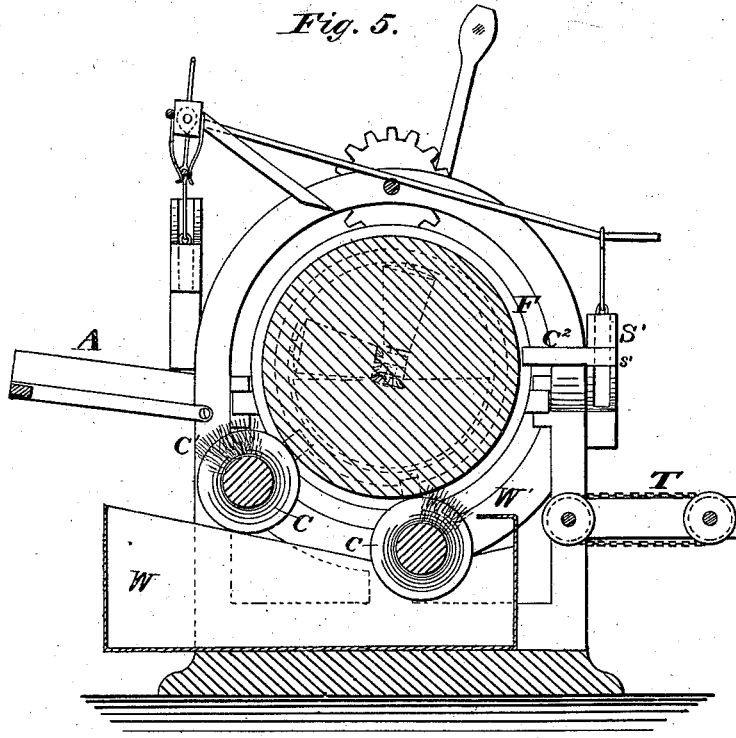
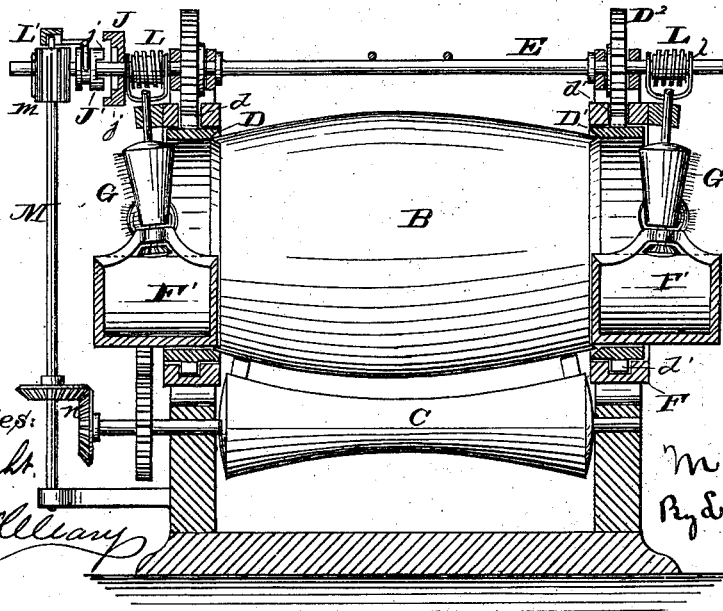

Fig. 6.



Witnesses:
A. Wright.
J. O. McIlroy

Inventor:
M. L. Deering.
By Sequest & Sequest
Atty.

UNITED STATES PATENT OFFICE.

MARK L. DEERING, OF CLEVELAND, OHIO, ASSIGNOR OF ONE-HALF HIS
RIGHT TO JULIUS T. EDSON.

IMPROVEMENT IN MACHINES FOR PAINTING BARRELS.

Specification forming part of Letters Patent No. **199,623**, dated January 29, 1878; application filed
March 29, 1877.

To all whom it may concern:

Be it known that I, MARK L. DEERING, of Cleveland, in the county of Cuyahoga and State of Ohio, have invented certain new and useful Improvements in Machines for Painting Barrels; and I do hereby declare the following to be a full, clear, and exact description of the invention, such as will enable others skilled in the art to which it pertains to make and use it, reference being had to the accompanying drawings, which form part of this specification.

My invention relates to devices for painting barrels; and consists in: chucks for receiving the revolving barrel in contact with brushes and mechanism for bearing the barrel away, and other appliances, substantially as herein-after set forth and claimed.

In the drawings, Figure 1 is a plan view; Fig. 2, a side elevation on the side where the power is applied. Fig. 3 is an end elevation adjacent to the conveyer. Fig. 4 is a side elevation on the side opposite the power. Fig. 5 is a longitudinal central section, by a vertical plane, containing the axis of the barrel; Fig. 6, a central cross-section, by a vertical plane perpendicular to the axis of the barrel; and Fig. 7, a separate view of a chuck, which is a variation of my invention.

The object of this invention is to paint the barrels both upon the body and end, and perform the operation readily and well.

A is a barrel-way, upon which the barrels are received. B is the barrel that is being operated upon. C are the paint-brush rollers. C¹ are the brushes upon the said rollers. C² are stops, so located with respect to the rollers that at the time when the barrel comes in upon the rollers these stops will serve to center the barrel in proper position to be clamped by the chucks. D D¹ are the chucks. These chucks are provided with gear-teeth or cogs d d', and they, in turn, mesh with pinions D² on the shaft E.

F are frames which surround the movable chucks. The frames F are made to slide in the main frame of the machine by means of guides f', in any suitable manner. The frames F also bear the paint-troughs F' and the paint-brushes G, which serve to paint the ends of

the barrel. The frames F are likewise connected, by levers H, with the shaft I, and at the points where they embrace the shaft I they are screw-threaded to fit upon the right and left hand screws i on the said shaft. The frames F likewise carry with them the movable chucks D D¹, and the cogs are sufficiently broad to remain in gear with the pinions D² as the frames F are moved in and out by the levers H as the shaft I is turned.

I' is a pulley, attached to suitable shafting, which will enable it to be thrown readily in or out of gear and reversed in its motion, at pleasure. (Said contrivance is not shown, but is too well known to need description, and forms no part of my invention.)

The object of the pulley I' is that, when the barrel is in proper position to be chucked, this pulley I' is thrown into gear, and, being rigidly connected to the shaft I, it turns the shaft, which, by its right and left hand screws, drives the tops of the levers H apart, and they, turning upon the pivots h, force the chucks together and clamp the barrel in place.

When the barrel is properly chucked the pulley I' is thrown out of gear until the barrel is painted. The pulley I' is then given a reverse motion, which releases the barrel, and the chucks are in position to receive the next.

E is the drive-shaft. It has a loose pulley, J, which connects with the driving mechanism.

J' is a clutch, and is provided with clutch-teeth j', corresponding to the small clutch-teeth j on the driving-pulley J. The clutch J' slides on a feather, j², on the shaft E.

A lever, k, serves to throw the clutch J' in or out of gear with the pulley J, and, of course, when in gear the pulley J causes the shaft E to revolve.

On the shaft E, and loosely connected therewith by feathers, so as to slide thereon, are worm-gears L L'. When the shaft E is revolved, these worm-gears likewise revolve.

The worm-gears L mesh with pinions g' on the tops of the shafts of the upright brushes G, and bevel-gears at the bottoms of these upright shafts mesh into corresponding bevel-gears in the horizontal brushes G', and impart revolution to them also.

As the frames F move in and out, the worm-gears L likewise move in or out on the shaft E, being carried by the frames l.

The worm-gear L', secured to the shaft E, meshes into a pinion, m, at the top of the shaft M. This shaft M, by means of the bevel-gears n, causes one of the paint-brushes to revolve.

The pinions P P¹ on the shaft of the brushes C gear into an intermediate pinion, P², thus giving both the brushes motion in the same direction. This, of course, might be effected by a belt passing over pulleys P, instead of by an intermediate gear mechanism shown.

The lever K has a couple of grooves, k k¹, upon its under surface, the object being as follows: A projecting pin, k², on top of the pinion m passes around through this groove, k, and in passing farther around passes into the groove k¹, and coming to the end of that groove it throws the lever K outward sufficiently far to release the clutch J' from the pulley J, thus stopping the motion of the shaft E, and consequently stopping the revolution of the barrel and the motion of the paint-brushes. The gearing is so arranged that when the pulley J is thrown out of gear the barrel shall have been revolved a sufficient number of times to become thoroughly painted, and the brushes C shall stop with the stops C² in proper position for centering the next barrel, and throw all the brushes off from the barrel.

Q is a lever, poised upon the shaft E, or upon some other suitable pivot. At the farther end of this lever is a friction-clutch, Q¹, which clutch is arranged to be opened by the upward motion of a lever, Q². When the lever Q is raised the clutch Q¹ comes down and clutches the cross-bar R. This cross-bar bears the stops S at its ends. The object of these stops is to drop down in front of the next barrel, to prevent its rolling into the machine until the first barrel has been painted and discharged. At the other end of the lever Q are attached the stops S' and arms s'. These stops serve also to assist in centering the barrel.

When it is desired to release the barrel from the machine, the chucks are opened to loosen the barrel. The lever Q is then raised, and thus lifting the stops S' away from the barrel, it rolls out by its own gravity. The lever Q is then pressed downward. The clutch Q¹ thus raises cross-bar R, with the stops S, from in front of the next barrel. The next barrel then rolls into the machine, and as it rolls in it strikes the lever Q², causing it to release the clutch Q¹, and permitting the stops S to fall down in front of the next barrel.

T is an elevator or conveyer, which receives the barrel B as it rolls from the machine and bears it away, and supports it until it has been partially dried by a current of warm or cold air, or in any suitable way.

W is a paint-trough, which supplies the

large paint-rollers. W' is a scraper at the side, which removes the surplus paint before the brush comes in contact with the barrel; and the brushes are so arranged that one will deliver the paint while the other will remove the surplus; and in the same way with the brushes that paint the ends of the barrel—the horizontal ones deliver the paint and the vertical ones remove the surplus; and similar scrapers may be provided at the side troughs.

Instead of employing the movable chucks D, as shown, all solid or in a single piece, the same may be formed of three or more parts, as shown in Fig. 7, wherein V is a rubber or other spring, located between the chucking-piece and that portion bearing the gear or cogs.

What I claim is—

1. A barrel-painting machine, consisting of movable chucks for clamping the ends of the barrel, in combination with mechanism, substantially as described, for revolving the barrel about its axis, and brushes for delivering paint to the surface of the barrel as it is revolved, substantially as and for the purposes described.

2. In a barrel-painting machine, the combination of the movable chucks for chucking the ends of the barrel, mechanism, substantially as described, for revolving the same about its axis, brushes for delivering paint to the surface of the barrel, and automatic mechanism for stopping the barrel when properly painted, substantially as and for the purposes described.

3. In a barrel-painting machine, the combination of the revolving chucks for clamping the barrel, mechanism, substantially as described, for revolving the same, and revolving brushes for applying the paint to the sides and ends of the barrel, substantially as described.

4. In a barrel-painting machine, the combination of frames F, levers H, and revolving chuck D, the chuck D being suitably geared with driving-power E, substantially as and for the purposes described.

5. The combination, with the chuck-supporting frames F, of the levers H and shaft I, substantially as described.

6. In a barrel-machine, the combination, with the stops S, of the lever Q, friction-clutch Q¹, and lever Q², substantially as and for the purposes set forth.

7. The combination of lever Q, clutch Q¹, rod R, and stops S', substantially as described.

8. The combination, with the lever Q, of the stops S' s', substantially as described.

9. The combination, with the drive-shaft E, of the pulley-wheel J, clutch J', and lever K, the said shaft provided with worm-gears L L', for operating the brushes, substantially as described.

10. The combination, with the shaft E, of the worm-gears L, made to slide upon the shafts by frames l, substantially as described.

11. The combination, with the clutch J' and lever K , provided with the grooves k k' , of the pinion m , provided with the stud k^2 , substantially as and for the purpose described.

12. The combination, with the clutch Q^1 and stops S , of the releasing-lever Q^2 , whereby a barrel in entering the machine releases the clutch Q^1 and interposes the stop S in front of the next following barrel, substantially as described.

13. The combination of projections or stops C^2 and s' , for centering the barrel, substantially as and for the purposes described.

In testimony whereof I have signed my name to this specification in the presence of two subscribing witnesses.

MARK L. DEERING.

Witnesses:

FRANCIS TOUMEY,
W. E. DONNELLY.