

J. McANESPEY.
 Securing Rotary Dashers in Churns.

No. 199,657.

Patented Jan. 29, 1878.

Fig. 1.

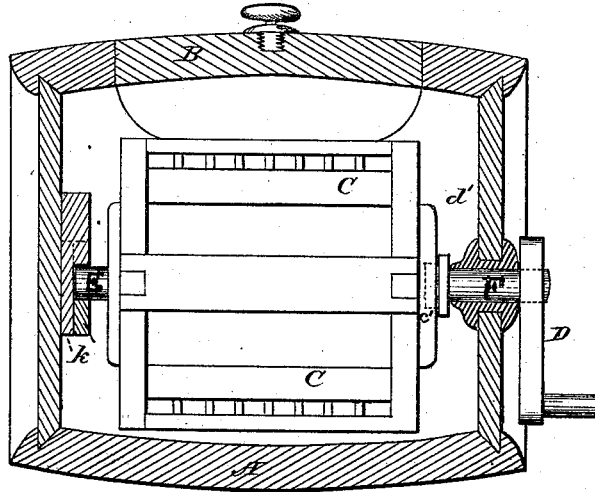

Fig. 2.

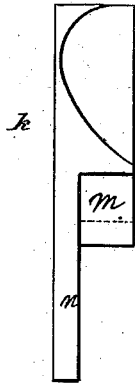

Fig. 3.

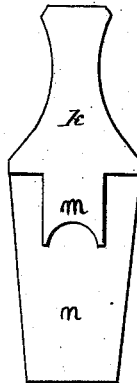

Fig. 4.

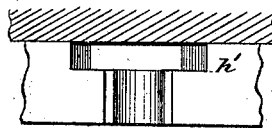
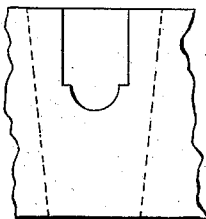

Fig. 5.



WITNESSES:

Arthur E. Perkins.
D. G. Stuart

John McAnespey,

INVENTOR.

J. M. C. Perkins
 ATTORNEY.

UNITED STATES PATENT OFFICE.

JOHN McANESPEY, OF PHILADELPHIA, PENNSYLVANIA.

IMPROVEMENT IN SECURING ROTARY DASHERS IN CHURNS.

Specification forming part of Letters Patent No. **199,657**, dated January 29, 1878; application filed November 1, 1877.

To all whom it may concern:

Be it known that I, JOHN McANESPEY, of Philadelphia, in the county of Philadelphia and State of Pennsylvania, have invented certain new and useful Improvements in Churns; and I do hereby declare that the following is a full, clear, and exact description thereof, that will enable others skilled in the art to which it appertains to make and use the same, reference being had to the accompanying drawings, and to the letters and figures of reference marked thereon, which form a part of this specification.

The same letters and figures of reference are used to indicate the corresponding parts.

After describing the invention, its nature and extent will be shown in the claims.

My invention relates to improvements in rotary churns. Its object is to furnish a churn whose dasher-shaft can be easily removed from the churn for the purpose of thoroughly and quickly washing both the dasher and the interior of the churn. It is cylindrical or barrel-shaped, and rests upon a stand of cross-legs.

Figure 1 is a cross-section of my churn, showing how the dasher is secured in its bearings by a key. Fig. 2 is an end view of the key. Fig. 3 is a front view of the same. Fig. 4 is a top view of the plate or shoulder in which one end of the dasher has its bearing. Fig. 5 is a view of the same when the key is in position.

A is the exterior of the churn, cylindrical in shape. B is the cover to an opening, through which the dashers or beaters C may be removed. D is the crank which gives motion to the beaters in the interior of the churn. In Fig. 1, *c'* is the slot in the shoulder *d'*, which is firmly attached to the dasher C, which receives the short shaft E, to which the crank D is attached. E is a short shaft, firmly fixed in the other end of the dasher C, which has its bearing in the shoulder *h'*, which is firmly attached to the interior of the churn. The key

k is made and adapted, as shown in Figs. 2 and 3, to hold the dasher-shaft E securely in its position. The shoulder *h'* is fastened to the inside of the churn, so as to receive the key *k* and the shaft E. This key is made with its sides inclined or wedge-shaped in its lower part. The raised portion *m* is made concave in its lower part, so as to fit over and confine the short shaft E in place. The lower portion *n* of the key is made thinner than the upper portion, so as to slide behind the end of the short shaft E when placed in position in the churn. When the key *k* is placed in its position at the end of the shaft E the raised part *m* fits over the upper part of the shaft E, while the lower thinner portion of the key falls down behind the end of the shaft. Thus the shaft E is firmly bound in its position in the churn by the key *k*.

Having now fully described my invention, what I claim, and desire to secure by Letters Patent, is—

1. In a rotary churn, the key *k*, made wedge-shaped on its sides, with the raised portion *m* made concave at its bottom, with the lower portion *n* of the key made thin, so as to slide behind the end of the shaft E, substantially as described, and for the purposes set forth.

2. The short shaft E and revolving dasher C, provided at opposite ends with the slot *c'* and short shaft E, in combination with the shoulder *h'* and key *k*, adapted to fit down upon and pass behind the shaft E, substantially as described and shown, and for the purposes set forth.

In testimony that I claim the foregoing I have hereunto set my hand this 14th day of July, 1877.

JOHN McANESPEY.

Witnesses:

WILLIAM McANESPEY,
GEORGE McANESPEY.