

L. F. JOHNSTON.  
Stirrup-Suspender for Riding-Saddles.

No. 199,716.

Patented Jan. 29, 1878.

Fig. 1.

Fig. 2.

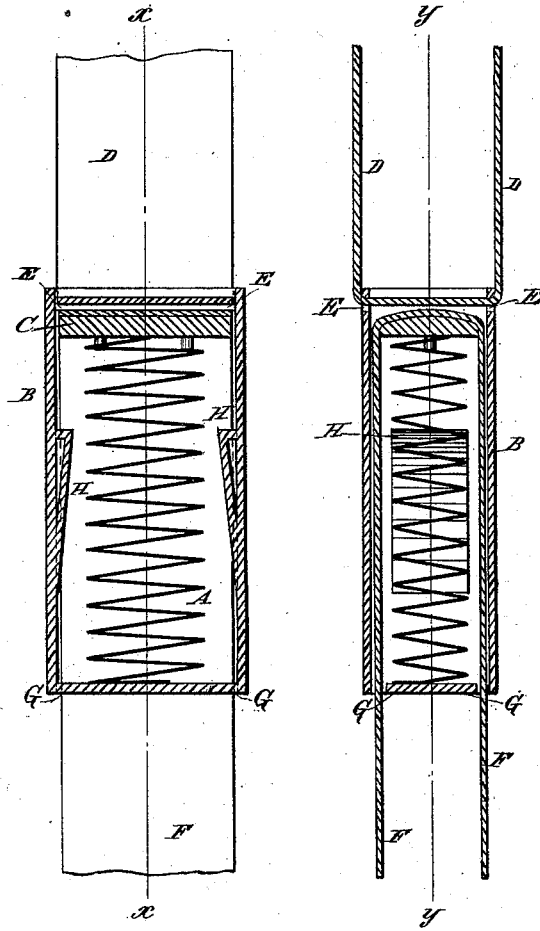

WITNESSES:

*H. Rydquist*  
*J. W. Scarborough.*

INVENTOR:

*L. F. Johnston*

BY

*Munn & Co.*

ATTORNEYS.

# UNITED STATES PATENT OFFICE.

LARKIN F. JOHNSTON, OF POCAHONTAS, ARKANSAS.

## IMPROVEMENT IN STIRRUP-SUSPENDERS FOR RIDING-SADDLES.

Specification forming part of Letters Patent No. **199,716**, dated January 29, 1878; application filed October 6, 1877.

*To all whom it may concern:*

Be it known that I, LARKIN F. JOHNSTON, of Pocahontas, in the county of Randolph and State of Arkansas, have invented a new and Improved Stirrup-Suspender, of which the following is a specification:

The invention will first be described in connection with the drawings, and then pointed out in the claim.

Figure 1 is a longitudinal vertical section of my improved stirrup-suspender. Fig. 2 is also a longitudinal vertical section of the same in a plane perpendicular to the plane of Fig. 1.

Similar letters of reference indicate corresponding parts.

A suitable spring, A, which, in the present example, is a spiral, works within and is guided by a case, B, and is compressed longitudinally between the bottom of case B and the movable plate C by force applied to said plate C, as from the pressure of a rider's foot in a stirrup attached to a saddle by means of my improved device, the said plate C being also guided by the case B, which case may have any suitable form and be made ornamental; but I prefer the rectangular form, as shown in the drawings. A saddle-strap, D, passes freely through suitable openings E near the top of the case B, to connect that case to a saddle, in such a manner that, in regulating or adjusting by the strap D the height of a stirrup or the distance of case B from the saddle, the said strap may move easily through the said openings E.

The plate C may be connected with a stir-

rup in any suitable manner by means of an inflexible rod or rods, not necessarily adjustable in length, passing through the bottom of case B, or by a flexible stirrup-strap, F, passing freely through suitable openings G in the bottom of case B, in such a manner that, in adjusting by strap F the distance of the plate C from the stirrup, the said strap F may be easily moved through the openings G and around the plate C.

The most convenient position for the spring is near the stirrup. Within the case B are suitable stops H, to hold the plate C and relieve the spring A when the rider is in the act of mounting.

I do not claim, broadly, a suspender for saddle-stirrups composed of a frame and inclosed spring and plate; but,

Having thus described my invention, I claim as new and desire to secure by Letters Patent—

As an improved manufacture, the device hereinbefore described, consisting of the rectangular case B, having parallel slots E E and G G at top and bottom to receive the stirrup-straps, the interior shoulders H H, the plate C, made narrower than the case to allow the lower strap to pass over it, and the spiral spring A, all constructed and arranged as shown and described.

LARKIN FARLEY JOHNSTON.

Witnesses:

WASHINGTON H. MALLOY,  
JOHN C. PHIPPS.