

W. JORDAN.  
Packing-Case.

No. 199,718.

Patented Jan. 29, 1878.

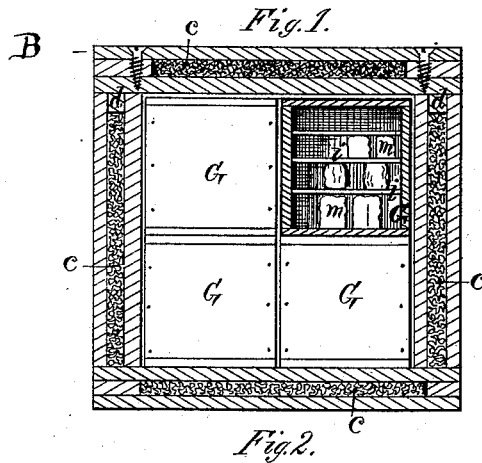
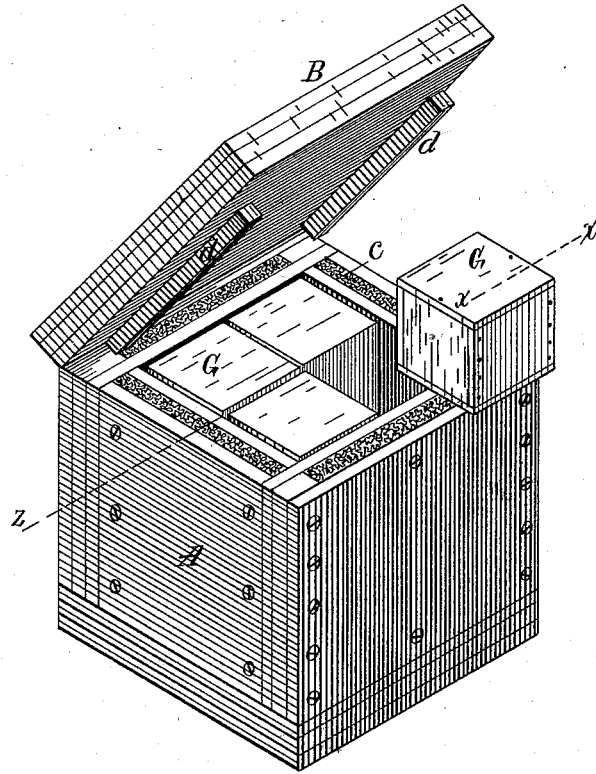

Witnesses:

Clarence W. Kendrick,  
Chas. R. Brainard

Inventor:  
William Jordan,  
By Chas. R. Brainard  
Atty.

# UNITED STATES PATENT OFFICE.

WILLIAM JORDAN, OF WATERVILLE, MAINE.

## IMPROVEMENT IN PACKING-CASES.

Specification forming part of Letters Patent No. **199,718**, dated January 29, 1878; application filed January 7, 1878.

*To all whom it may concern:*

Be it known that I, WILLIAM JORDAN, of Waterville, in the county of Kennebec, State of Maine, have invented a certain new and useful Improvement in Packing-Cases, of which the following is a description sufficiently full, clear, and exact to enable any person skilled in the art or science to which my invention appertains to make and use the same, reference being had to the accompanying drawings, forming a part of this specification, in which—

Figure 1 is an isometrical perspective view, showing the case with its cover partially opened and one of its boxes removed; and Fig. 2, a vertical transverse section of the case, taken on the line *z*, and also of one of its boxes, taken on the line *x x*.

Like letters of reference indicate corresponding parts in the different figures of the drawing.

My invention relates to that class of packing-cases which are designed for transporting and preserving butter; and consists in a novel construction and arrangement of the parts, as hereinafter more fully set forth and claimed, by which a simpler, cheaper, and more effective device of this character is produced than is now in ordinary use.

In the drawing, A represents the body of the case, and B the cover, which may be hinged to the body in any convenient manner, or be wholly detachable, as preferred. The sides, bottom, and cover of the case are hollow, or provided with chambers *c*, which are filled with wool, as best seen in Fig. 2, and disposed within it there are a series of removable boxes, G, cubical in form, and of such a size that when they are all in position they exactly fill the case. These boxes are designed to contain the butter, and are each provided with a series of shelves or followers, *i*, on which the uppermost courses or tiers of butter-balls rest, as seen in Fig. 2.

In the use of my improvement the boxes G are first taken from the case, after which their covers are removed, and the followers *i* taken out. A layer of butter, *m*, (if in balls,) is then deposited on the bottom of each box, and a follower, *i*, placed on the butter, after which other layers and other followers are inserted in like manner until the boxes are completely

filled. The covers are then secured in any convenient way, and the boxes again placed within the case, and its cover closed and fastened down.

It will be understood that one or more of the boxes may be employed for packing the butter, according to the quantity, but that all of them are to be returned to the case, whether filled or not, as they act to keep each other in position during transportation, and also to balance the case.

The object of the followers *i* is to prevent the superposed layers of butter from injuring the lower layers during transportation, and also to exclude the air and dust from the lower portions of the box when the cover is removed; but when the butter is in bulk they are not required.

The cover B is provided with downwardly-projecting cleats or flanges *d*, which, as the cover is closed, enter the spaces in the sides of the case in which the wool *c* is contained, the wool yielding to permit this, thus forming a tight joint between the cover and box, and excluding the heated air, dust, &c.

It will be understood that the front and rear of the cover are designed to be provided with similar flanges, when the cover is not hinged; and that the chambers in the front and rear walls of the box, as well as the sides, are to be open at the top to admit the entrance of the additional flanges.

Farmers and dairymen who have but small quantities of butter to transport at a time have found great difficulty in getting it to market in good condition, especially in hot weather.

My invention is designed more particularly to obviate this difficulty, although adapted to the packing and transportation of butter in larger quantities, when required, as will be readily obvious to all conversant with such matters from the above description.

I prefer to construct the cover B with four flanges, arranged to enter the upper portions of the chambers containing the wool, and not to hinge it to the body of the case, as a more perfect joint is thus produced. I also prefer to construct the flanges of tin or sheet metal to obviate the expansion from moisture which sometimes occurs when wood is used, and

causes the cover to bind, thereby preventing its ready removal. The wool, being elastic, acts expansively in the chambers *c*, pressing upwardly against the flanges, thus packing or closing the joint between the cover and body of the case. It is also a non-conductor of heat, and serves to keep the contents of the case cool.

Having thus explained my improvement, what I claim is—

The improved packing-case described, con-

sisting of the body *A*, provided with the chambers *c*, packed with wool, the cover *B*, provided with the wool-packed chamber *c* and flanges *d*, and the cubical boxes *G*, constructed, combined, and arranged to operate substantially as and for the purpose set forth and specified.

WILLIAM JORDAN.

Witnesses:

L. D. CARVER,  
WM. T. JORDAN.