

F. M. McCrory.
Bellows.

No. 199,846.

Patented Jan. 29, 1878.

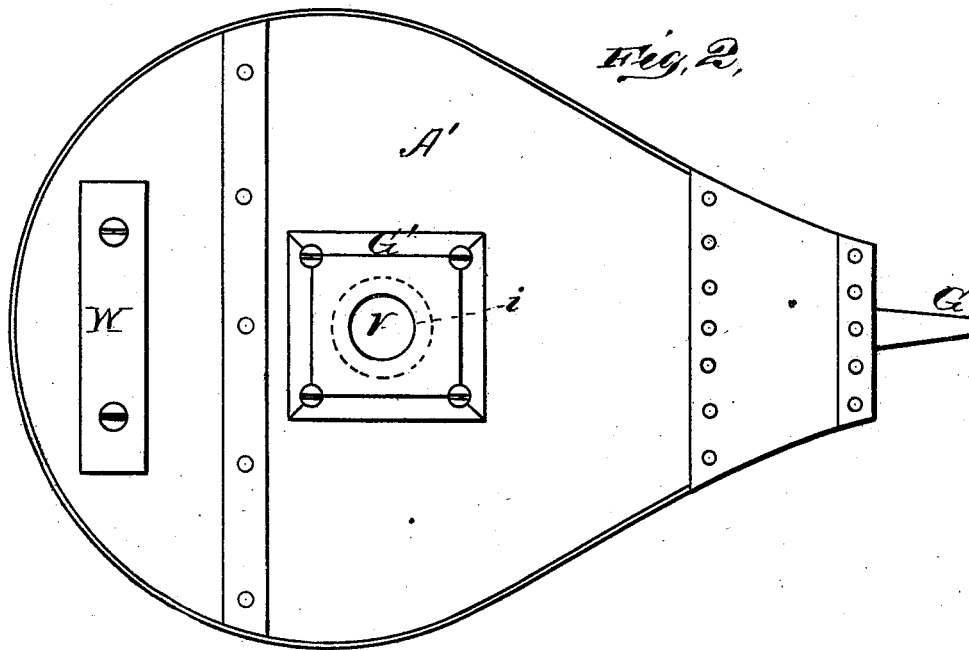
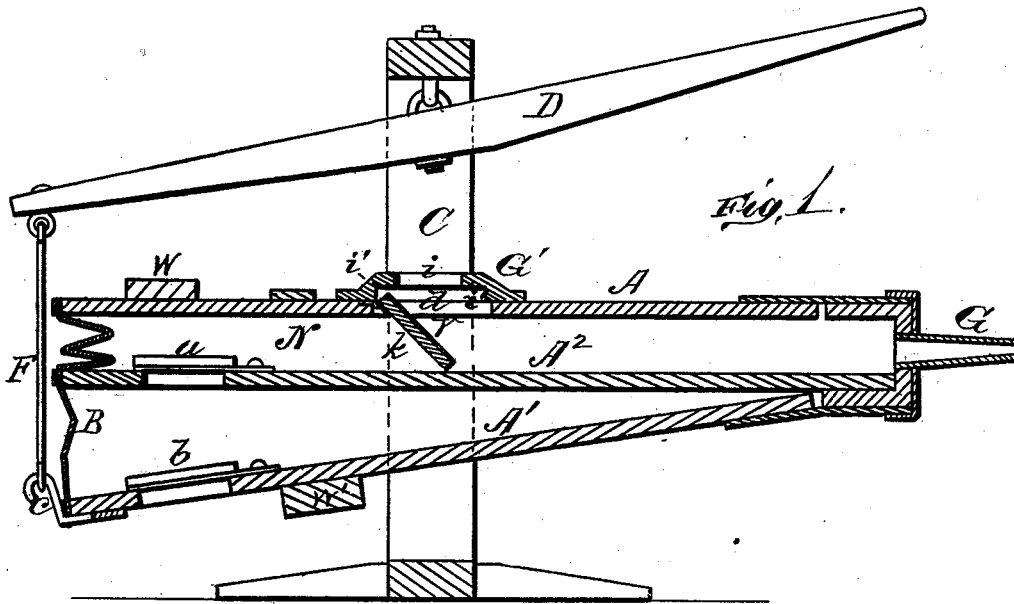

WITNESSES
H. Bates
C. J. Chase

INVENTOR
Franklin M. McCrory
By E. W. Anderson

ATTORNEY

UNITED STATES PATENT OFFICE.

FRANKLIN M. McCRORY, OF GOSHEN, INDIANA.

IMPROVEMENT IN BELLOWS.

Specification forming part of Letters Patent No. **199,846**, dated January 29, 1878; application filed December 8, 1877.

To all whom it may concern:

Be it known that I, FRANKLIN M. McCRORY, of Goshen, in the county of Elkhart and State of Indiana, have invented a new and valuable Improvement in Bellows; and I do hereby declare that the following is a full, clear, and exact description of the construction and operation of the same, reference being had to the annexed drawings, making a part of this specification, and to the letters and figures of reference marked thereon.

Figure 1 of the drawings is a representation of longitudinal central section of my improved bellows; and Fig. 2 is a top view thereof.

This invention has relation to improvements in forge-bellows.

The object of the invention is to devise means, in connection with a bellows, for producing a current or draft of air through it, whereby the fire in the forge will be kept alive when the bellows is not in use, and whereby its interior will be kept free of gas.

The nature of the invention consists, for the accomplishment of these results, in the combining with a double-chambered bellows a downwardly-opening valve in the upper board of the top chamber, which will fall when the said chamber is collapsed from the expulsion of air, and establish a draft or current of air, as will be hereinafter more fully set forth.

In the annexed drawings, the letters A¹ A² designate, respectively, the top, bottom, and middle boards of a double-chambered bellows, connected together by means of leather or other suitable material, B.

The boards are of the usual form, and the central one, A², is provided with projecting trunnions, by means of which it is journaled in an upright frame, C, or other like device. This middle board is stationary with reference to the upper and lower ones, which are movable, and is provided with a valve, *a*, opening upward. The lower board has also a valve, *b*, opening upward, and is provided with a hook, *c*, at its heel, by means of which it is connected to an operating-lever, D, by means of a connecting-rod, F, or other equivalent de-

vice. The upper chamber is provided with a (preferably) tapering tuyere, G, through which the air is forced into the forge, and its upper wall A with a valve, V, opening upward and closing an orifice, *d*, when the said chamber is filled with air. This valve is composed of a plate, G', having an orifice, *i*, registering with a larger orifice, *d*, in the board, and of a flap, *k*, of any suitable material, preferably wood, covered with a packing substance. The flap *k* is of greater width than the orifice *i*, and fits snugly into an annular rabbet, *i'*, upon the under side of plate G, forming an airtight joint therewith.

When the lever D is actuated, air is admitted through the valve *b* into the lower chamber of the bellows, whence it passes through the valve *a* in the center board A² of the bellows into the upper chamber N thereof, thereby closing the valve V. The bellows, under these circumstances, is double-acting, and discharges a continuous stream of air into the forge-fire, its effects not differing essentially from those of the ordinary double-chambered bellows; but when the operation of the lever ceases the upper wall of the chamber N gravitates, closes the valve *a*, and expels its atmospheric air. The valve V then drops, thereby disclosing the orifices *i* *d*, and establishing a draft through the bellows, which will keep the forge-fire alive without creating undue combustion, and allow gases generated by the burning of the coal to escape from the said chamber.

It is well known that in the ordinary double-action bellows carbonic acid and carbonic-oxide gases of great density accumulate in the upper chambers, and are expelled when the bellows is worked, at the first stroke of the lever. These gases are absolutely destructive of combustion, and almost invariably extinguish any remaining fire in the forge.

What I claim as new, and desire to secure by Letters Patent, is—

1. The combination, in a double bellows having a valved center board, of a valved lower board adapted to be operated by means

of a lever, and an upper board adapted to operate by its own gravity or by means of a weight, and provided with a draft-valve for the escape of any gases that may collect in the bellows when idle, substantially as specified.

2. The valve for bellows consisting of the seat-plate *G'*, having orifice *i* and an annular rabbet, *i'*, and a flap, *k*, hinged to the said

plate, fitting in the said rabbet and closing the said orifice, substantially as specified.

In testimony that I claim the above I have hereunto subscribed my name in the presence of two witnesses.

FRANKLIN M. McCRORY.

Witnesses:

WELCOME WHITAKER,
HENRY V. CURTIS.