

C. A. TABOR.
 Stop-Motion for Railway Drawing Heads.

No. 199,878.

Patented Jan. 29, 1878.

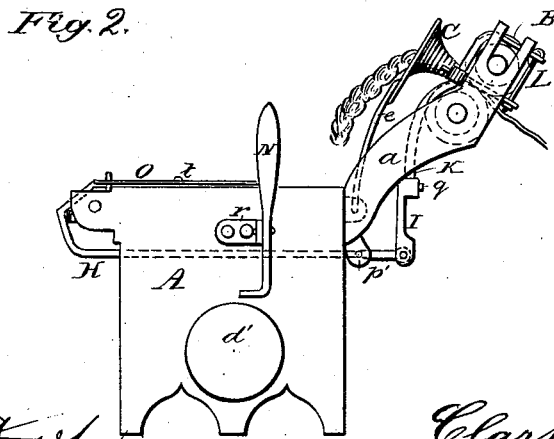
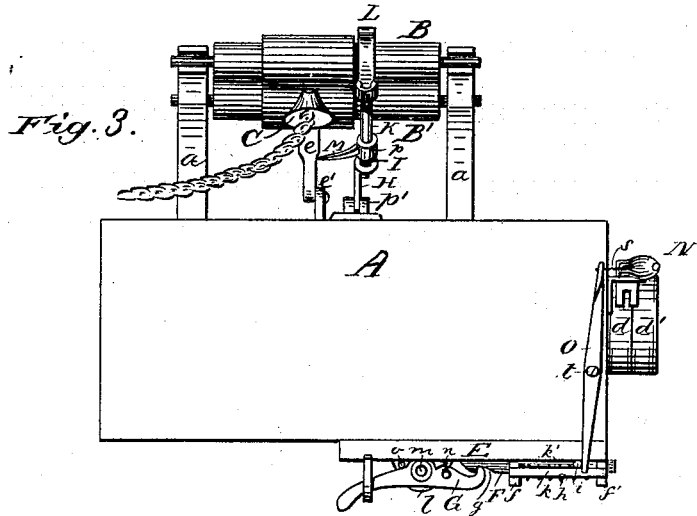
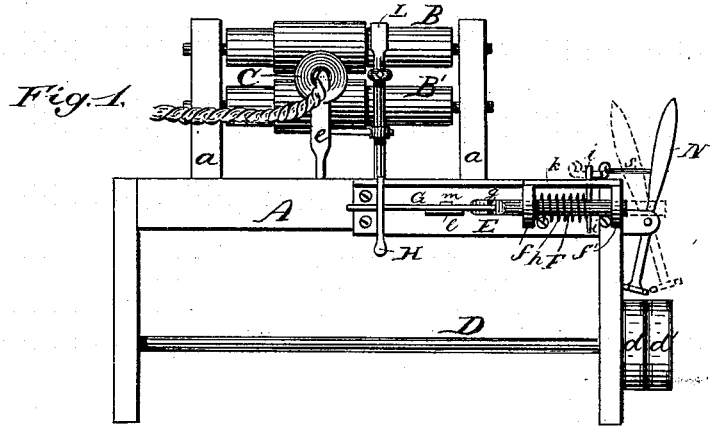

Attest:
August Peterson
 C. H. Hansen.

Inventor:
 Clark A. Tabor,
 by *C. A. Snow & Co.*
 attys.

UNITED STATES PATENT OFFICE.

CLARK A. TABOR, OF HOPE VALLEY, RHODE ISLAND.

IMPROVEMENT IN STOP-MOTIONS FOR RAILWAY DRAWING-HEADS.

Specification forming part of Letters Patent No. **199,878**, dated January 29, 1878; application filed October 17, 1877.

To all whom it may concern:

Be it known that I, C. A. TABOR, of Hope Valley, in the county of Washington and State of Rhode Island, have invented certain new and useful Improvements in Stop-Motions for Railway Drawing-Heads; and I do hereby declare that the following is a full, clear, and exact description thereof, which will enable others skilled in the art to which it appertains to make and use the same, reference being had to the accompanying drawing, which forms a part of this specification, and in which—

Figure 1 is a part elevation. Fig. 2 is an end view, and Fig. 3 is a top plan.

Similar letters of reference indicate corresponding parts in all the figures.

This invention relates to stop-motions for railway drawing-heads; and it consists in an improved construction and combination of parts, as hereinafter more fully explained, and pointed out in the claims.

In the drawing, A is the platform or table which supports the drawing-frame and its operating mechanism. (Not shown in the drawing.) *a a* are the brackets supporting the compact rollers B B', and C is the trumpet for conducting the roving in between the rollers. D is the shaft which operates the machinery, and *d* is a fixed and *d'* a loose belt-pulley at the end of said shaft. The trumpet C is secured upon the end of an arm, *e*, pivoted at *e'*. To the front side of the table A is secured a plate, E, having two perforated bearings, *f f'*, in which slides a bolt, F, terminating at its inner end in a catch or notch, *g*. Around bolt F is placed a coiled spring, *h*, abutting at one end against the bearing *f*, and, at the other end, working against a pin, *i*, inserted transversely through the bolt.

k is a narrow strip or plate, screwed, or otherwise secured, upon the top of the brackets *f f'*, so as to form a narrow slot, *k'*, between it and the upper flange of plate E, in which the head of pin *i* slides, projecting up above said slot, as shown.

G is a latch, pivoted in a projecting plate, *l*, at *m*, and curved a little outward at one end, while the other end forms a hook which takes with the notch *g* in bolt F. The notched

end of bolt F is beveled, so as to readily engage with the hook of latch G when the bolt is pushed back for the purpose of setting the attachment; and the latch is kept in the proper position to take with the bolt by a small spring, *n*, and a stop-pin, *o*.

H is a lever, having its fulcrum in a bearing, *p'*, secured to the back or under side of table A. The forward end of this lever is bent upward, as shown in Fig. 2, so as to engage with the curved end of latch G. The other end of lever H is pivoted in an arm, I, which terminates in a socket, *p*, into which a bent rod, K, is inserted, and kept in place by a set-screw, *q*, thus admitting of the ready adjustment of rod K. The upper end of this rod forms an oblong loop, L, through which passes one end of the enlarged shaft of the upper compact roller B, the loop or eye being so constructed that the shaft will rotate freely within it.

M is an adjustable arm, secured upon rod K, from which it passes sidewise and in front of the hinged arm *e*, upon which the trumpet C is secured.

The belt-shifter N is pivoted in a bracket, *r*, in the end piece of table A, a short rod, *s*, passing through a perforation in the upper end or handle, which connects with a horizontal lever-arm, O, having its fulcrum at *t*, the other end of which projects out over the slot *k'*, formed between the guide-strip *k* and flanged plate E.

From the foregoing description, taken in connection with the drawing, the operation of my invention will be readily understood. The roving having been passed through the trumpet, in between the compact rollers in the usual manner, the machine is started by turning the belt-shifter N so as to bring the belt over upon the fixed pulley *d*. At the same time bolt F is coupled, with its notched end onto latch G, as shown in Fig. 1 of the drawing, the projecting end of lever-arm O impinging, when bolt F is in this position, against the head of pin *i*, which projects up through the slot *k'*.

If, during the operation of the machine, the roving should break while passing through, or after it has passed through, the trumpet C, the strain upon this, caused by the roving

passing through its narrow opening, will cease, and the trumpet, with its hinged arm *e*, will fly back from the head B B', thereby pushing against arm M, and consequently impelling rod K forward and downward, which again operates lever H, to which it is hinged by its socket *p* and arm I, so as to elevate its bent front end, thereby releasing latch G from its hold upon bolt F; and the latter, impelled by the coiled spring *h*, will fly back, carrying with it the pin *i*, which works against the projecting end of the lever-arm O, forcing this back so as to operate the belt-shifter in such a manner as to shift the belt from the fixed pulley *d* to the loose pulley *d'*, which stops the machine. Similarly, if the roving should break before passing through the head, but after it has passed the trumpet, the upper compact roller B will descend upon the lower roller a distance corresponding to the thickness of the roving, which is sufficient to tilt rod K and lever H through the intermediate link I, one end of the upper head projecting through the loop or bearing L, which is formed at the upper end of rod K for that purpose, thereby operating latch G, bolt F, lever-arm O, and the belt-shifter N, in the manner already described, so as to instantly stop the machine until the broken ends of the roving have been reunited.

The object of making rod K adjustable, in the manner described, is to make it more or less sensitive to the fall or depression of the upper compact roller B when a sliver breaks, and thereby insure perfect operation of the

mechanism, whenever this contingency arises, by having the loop or bearing L of said rod always in immediate contact with the roller by the fall or depression of which it is operated.

Having thus described my invention, I claim and desire to secure by Letters Patent of the United States—

1. In a railway drawing-head, the plates E *k*, in combination with latch G, spring *h*, and bolt F, having pin *i* projecting up through the guide-slot *k'*, formed between said plates E and *k*, whereby pin *i* serves the double purpose of preventing the bolt from turning in its bearings or brackets, and of operating the belt-shifting mechanism, substantially as and for the purpose herein shown and specified.

2. In combination with the compact rollers and trumpet of a railway drawing-head, the operating mechanism herein described, for stopping automatically the motion of the head on the breaking of the roving, consisting essentially of the adjustable rod K, arm I, lever H, latch G, bolt F, lever-arm O, and belt-shifter N, all combined to operate substantially as and for the purpose herein shown and specified.

In testimony that I claim the foregoing as my own I have hereto affixed my signature in presence of two witnesses.

CLARK A. TABOR.

Witnesses:

WILLIAM B. WESTCOTT,
LOVINA RICHMOND.