

J. S. THOMAS.
Jail-Cells.

No. 199,879.

Patented Jan. 29, 1878.

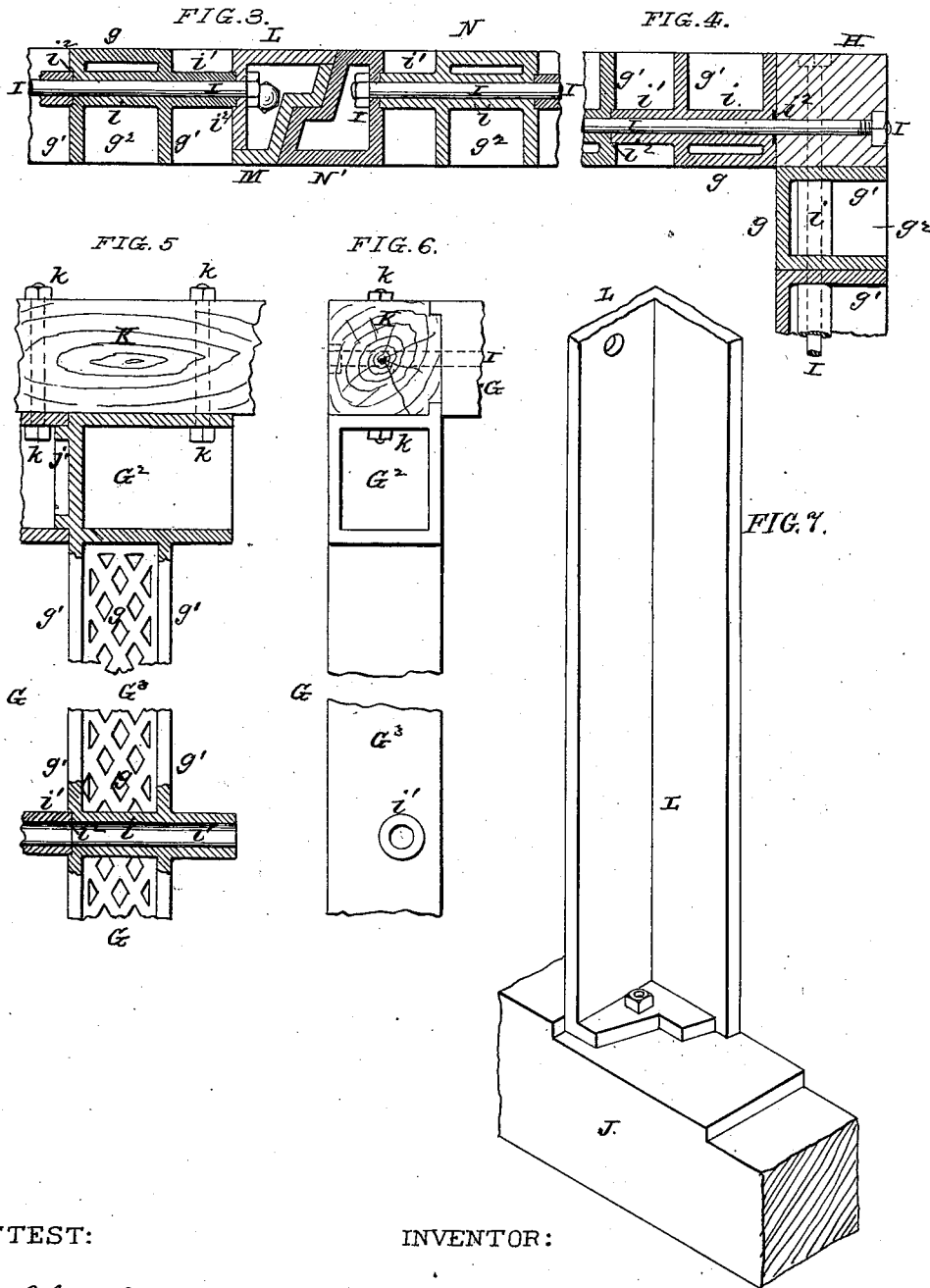

ATTEST:

*Robert Burns
Chas. Hall*

INVENTOR:

*John S. Thomas
per Wright Bros.
attys.*

UNITED STATES PATENT OFFICE.

JOHN S. THOMAS, OF FORT WORTH, TEXAS, ASSIGNOR TO ELLEN C. THOMAS,
OF SAME PLACE.

IMPROVEMENT IN JAIL-CELLS.

Specification forming part of Letters Patent No. **199,879**, dated January 29, 1878; application filed
May 18, 1877.

To all whom it may concern:

Be it known that I, JOHN S. THOMAS, of Fort Worth, Tarrant county, Texas, have invented certain new and useful Improvements in Construction of Jail-Cells, of which the following is a specification:

My improvement consists in constructing the cell and corridor walls of sections of chilled cast-iron, each section being formed with a recess on the outer side, with transverse tubular ribs extending from side to side of the recess, and traversed by horizontal wrought-iron rods, by which the sections are connected together.

The sections are shown a small distance apart, and each section on one side has a tubular projection or distance-stud fitting in a recess of the next section, which stud may be separate, but fitting in between the vertical pieces, with recess in each to receive stud, and through which passes the rod by which the sections are connected together.

The tubular ribs and studs completely hide the connecting-rods. At the corners are wooden posts, through which the connecting-rods pass, as shown, so as to attach the walls together, the iron covering completely the wood at the inside of the cell.

In the drawings, Figure 1 is a horizontal section, showing a cell, corridor, and vestibule at one corner of a jail. Fig. 2 is an outside elevation of a doorway. Fig. 3 is a horizontal section through one edge of the door and frame. Fig. 4 is a horizontal section through one corner of a cell. Fig. 5 is an inside elevation of parts of one of the cast sections entering into the construction of the walls, part in section. Fig. 6 is an edge view of parts shown in Fig. 5. Fig. 7 is a perspective view of a part of the lower end of one of the door-posts.

A A are the outer walls of the jail, faced upon the inner side with a sheeting, *a*, of sheet-iron. Attached around the embrasure or openings are chilled castings B, forming a lining thereto. C is a cell. D is a corridor, usually communicating with a number of cells. E is a vestibule between the corridor and the hall F.

The cell-walls are formed of a number of upright cast-iron sections, G, standing side by side, and attached together and to the corner-

posts H by horizontal bolts I, extending through the sections and corner-posts or door-frames, as the case may be. Each section consists of a face-plate, *g*, side flanges or ribs *g*¹, and hollow castings G¹ at bottom and G² at top. The lower and upper ends G¹ and G² are attached to the sills J and head beams K by bolts *j* and *k*, whose heads are in the hollows, as shown. The foot and head castings are cast in one piece with the upright portion G³, forming with it one section, G, presenting a flat surface, *g*, to the interior of the cell and a recess upon the outside, as shown at *g*².

It will be seen that the head G² and base G¹ are open upon one side, so that access can be had for the insertion of the bolt; and this opening is closed by the next section as it is added to the wall, as shown in Fig. 5, where said hollow or recess is shown in section. It will be seen that the tops fit together with a rabbet-joint at *j*'.

The cast sections are made with transverse ribs *i* extending across the recess *g*², and in line with the rib *i* is a stud, *i*¹, extending from section to section. The stud *i*¹ and rib *i* are centrally bored for the passage of the rod I.

The stud *i*¹ may be cast solid with one section, and fit in a recess, *i*², of the next section, as shown, or it may be made in the form of a detached collar for the bolt I, and fit in recesses *i*² in both sections.

Thus it will be seen that no part of the horizontal bolt I is exposed.

The floor and ceiling of the cell are made up in the same manner as the sides, except that the sections may be in close contact throughout their length. They are attached, respectively, to the sills and head timbers, in such a way as to hide said timbers from view, so that the prisoner cannot work upon them. In any of the walls the sections may in like manner be put in close contact, or the spaces between them be wider or narrower.

In making the door-frames I first erect angle-posts L at the sides, and through them pass the bolts I, as shown in Figs. 1 and 6, said bolts securing them to the walls. Then against the posts L, I erect the door-frame M M M¹ M², of which M M are the uprights, M¹ the threshold, and M² the lintel. This frame is cast in

one piece, and is attached to the sill by bolts *m*, and to the top beam by bolts *m'*, the heads of the bolts being in recesses, so as to allow the door *N* to close tightly in the frame; and when the door is closed it covers up the bolt-heads. The door is constructed of sections *G*, substantially like those of which the walls are formed.

The sides *N'* of the doors are formed to fit the sides of the doorway, and are hollow, to contain the head and nut of the horizontal bolts *I*, the latter being reached by a socket-wrench, inserted through a hole in the side piece *N'*, said holes being closed when the door is shut; or they may be permanently stopped in any suitable way.

I claim herein as new and of my invention—

1. The walls for jail-cells formed of vertical

sections *G*, secured together by through-bolts *I*, substantially as set forth.

2. In combination with the bolts *I* and sections *G*, the transverse tubular bars for the concealment of the bolts, as set forth.

3. The jail-cell constructed of the cast sections *G*, through-bolts *I*, and corner-posts *H*, and sill and head timbers *K*, substantially as set forth.

4. The lining of the outer or main walls of jails with sheet-iron, in connection with the narrow windows, lined with chilled cast-iron, substantially as set forth.

JOHN S. THOMAS.

Witnesses:

B. R. ELLIOTT,
W. T. STEELE.