

J. G. COOPER.  
Steam-Engine.

No. 199,961.

Patented Feb. 5, 1878.

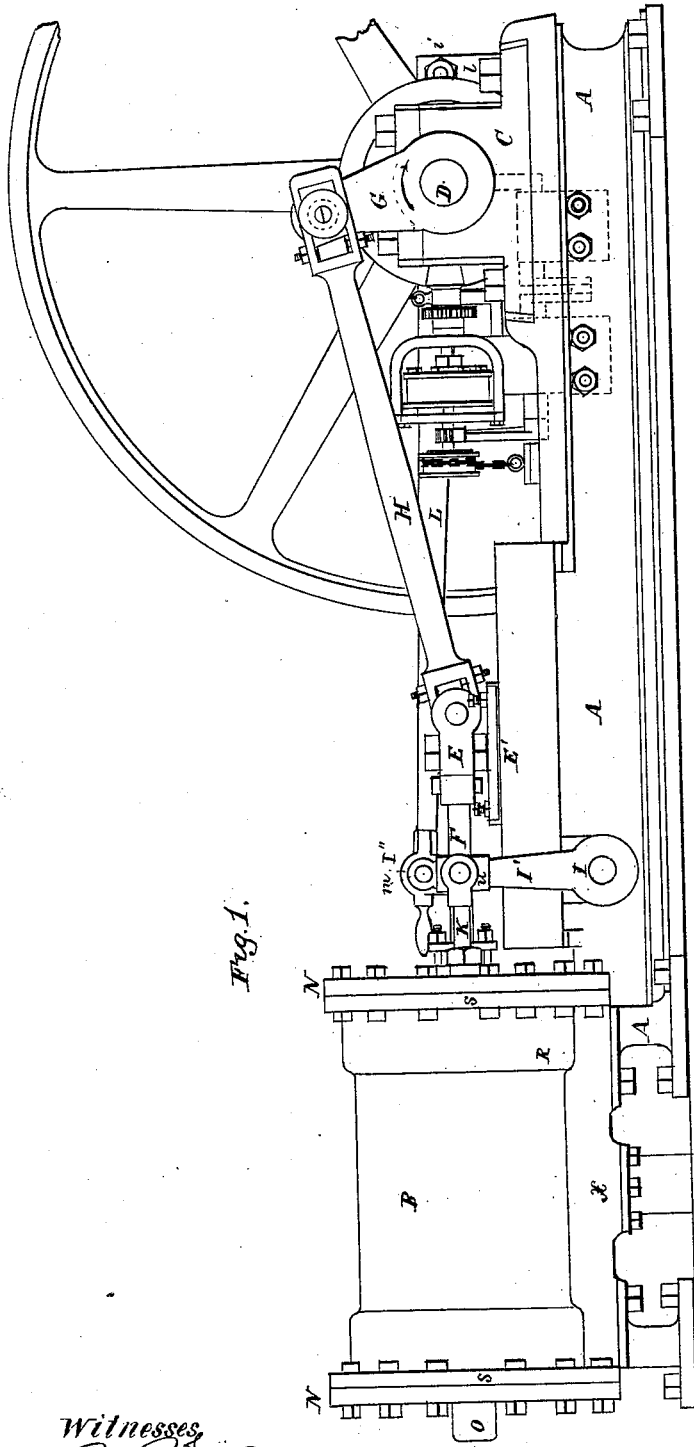

Fig. 1.

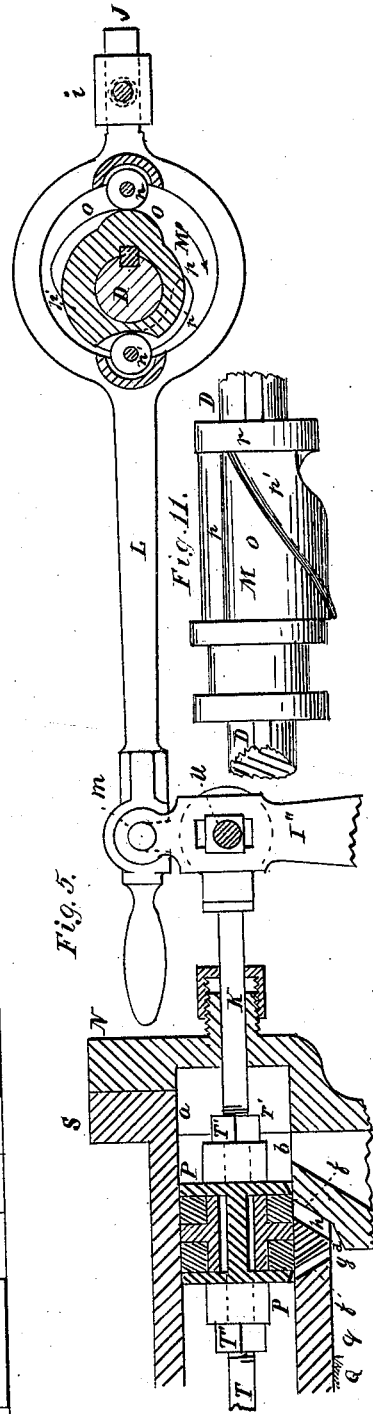

Fig. 5.

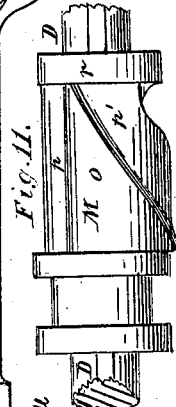

Fig. 11.

Witnesses  
*B. R. Wells*  
*R. Boehm*

Inventor:  
*James G. Cooper*



J. G. COOPER.  
Steam-Engine.

No. 199,961

Patented Feb. 5, 1878.

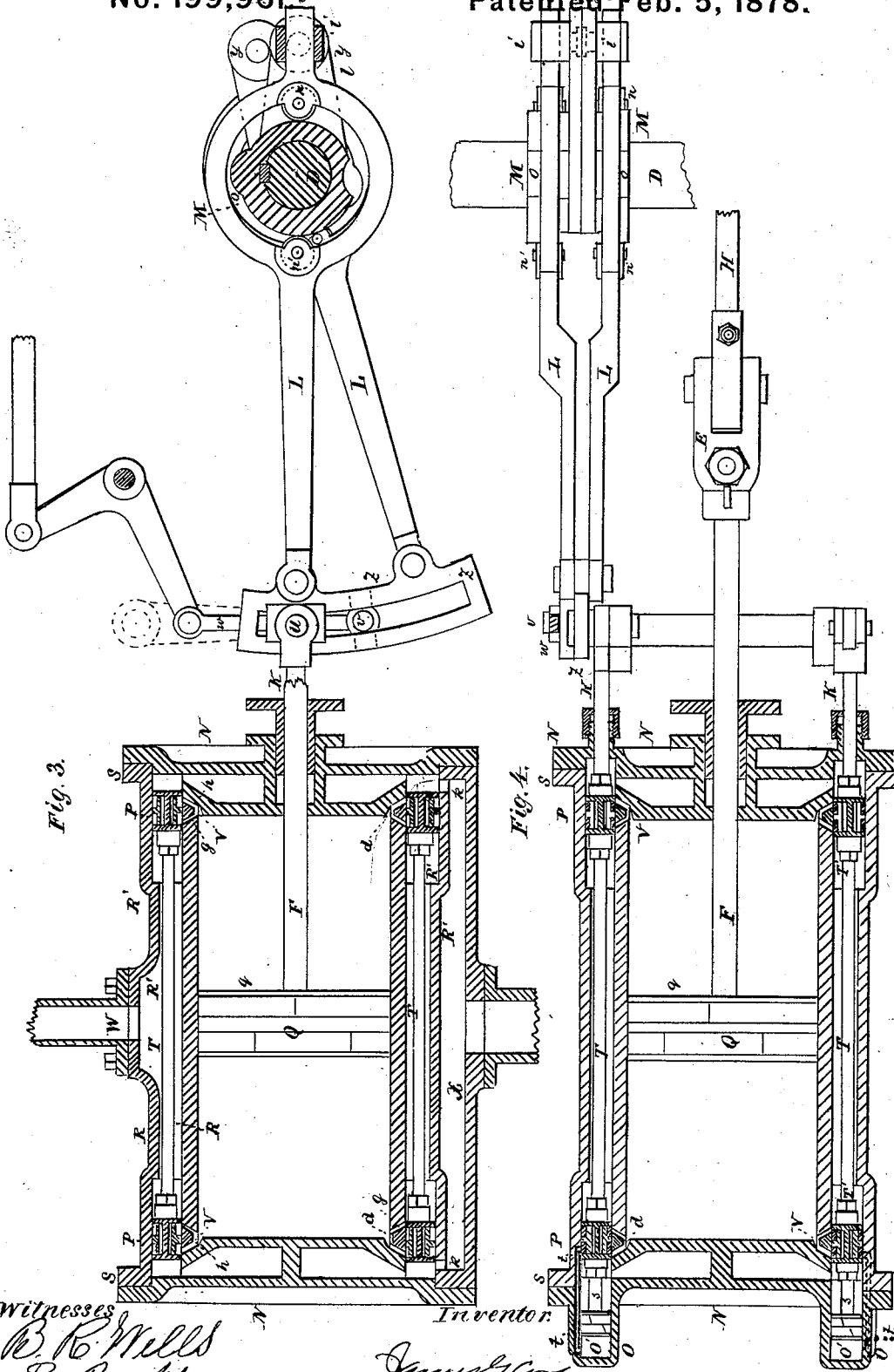

Witnesses  
B. R. Mills  
R. Baekley

Inventor  
James G. Cooper



# UNITED STATES PATENT OFFICE.

JAMES G. COOPER, OF BROOKLYN, NEW YORK.

## IMPROVEMENT IN STEAM-ENGINES.

Specification forming part of Letters Patent No. **199,961**, dated February 5, 1878; application filed January 29, 1877.

*To all whom it may concern:*

Be it known that I, JAMES G. COOPER, of the city of Brooklyn, in the county of Kings and State of New York, have invented new and useful Improvements in Steam-Engines, which improvements are fully set forth in the following specification, reference being had to the accompanying drawings.

This invention more especially relates to steam-engines in which an annular valve surrounding the ends of the engine-cylinder, and arranged between the latter and an outer steam case or jacket, is used to control the motion of the engine-piston.

The invention consists in certain novel constructions and combinations of parts, whereby the cylinder-covers are made to partly form the valve-seat, also to provide for a free passage of the exhaust-steam through them, and, in connection with the ends of the cylinder, to form inlet and outlet ports, likewise whereby the annular valve has combined with it pistons moving in the same line or course to aid in the movement of the valve.

Referring to the accompanying drawings, Figure 1 represents a side elevation of a stationary engine designed to rotate mainly in one and the same direction, and having my invention applied. Fig. 2 is a top view or plan of the same. Fig. 3 is a longitudinal vertical section upon a larger scale of an engine, in part, having my invention applied in connection with a reversible valve-gear and link motion applicable to locomotive and other reversible engines. Fig. 4 is a horizontal section of the same, and Fig. 5 a transverse section thereof. Fig. 6 is a vertical longitudinal section upon an enlarged scale of one end of the cylinder with the main valve applied thereto. Fig. 7 is a transverse section of one of the cylinder-heads, with attached inner ring constructed to form a portion of the valve-seat, and Fig. 8 a view of said valve-ring detached from the cylinder-head. Fig. 9 is an inside face view of the cylinder-head with its attached inner valve-ring. Fig. 10 is a longitudinal section of a portion of the valve with the engine-cylinder and its head in connection with a valve-gear applicable to stationary engines. Fig. 11 represents a top view of a cam used in such valve-gear.

A, Figs. 1, 2, is the frame of the engine, carrying at its one end the engine-cylinder B, and at its opposite end the bearings C of the engine-shaft D. E is the cross-head of the engine, secured to the piston-rod F, and arranged to slide in guides E' E' on the engine-frame, and connected by a rod, H, with the crank G on the main shaft.

I is a rock-shaft, having its bearings in the main frame a little in advance of the forward end of the engine-cylinder. Said rock-shaft has attached to it, on opposite sides of the axial line of the piston-rod, two upwardly-projecting arms, I' I'', which are connected by rods K with the slide or main valve of the engine. One of said arms is also connected with the eccentric or cam rod L of the valve-gear, which rod is operated by means of a cam or eccentric, M, mounted upon the main shaft D, to control the motion of the main valve.

N N are the two cylinder-heads, which are of a similar general construction, but the forward one of which has three stuffing-boxes—viz., one for the piston-rod of the engine and two for the rods K—which work the main valve and two pistons on the rear end of the main valve working in small auxiliary cylinders O O, which pistons serve to assist the movement of the main valve or valves P P.

Q is the piston of the engine. The main cylinder B of the engine is constructed with an interior or working cylinder, B', within which the piston Q works. Around said working-cylinder B' is an exterior cylinder, R, leaving a space between them to form a steam-jacket, R', around the working-cylinder B'. This steam-jacket projects beyond both ends of the working-cylinder, and the cylinder-flanges, to which the heads N N are bolted, are formed on the jacket, and are of like diameter with said heads. Said jacket is connected with the working-cylinder B' by means of radial ribs or strips B'', which extend longitudinally for a certain or limited distance within the cylinder B, toward opposite ends of the latter.

Each end of the jacket and the outer or opposite ends of the cylinder B' are both turned smooth and cylindrical from the faces of the flanges S S of the jacket to the ends of the ribs B''. In each of the annular spaces thus produced at the ends of the cylinder B', between the latter

and the outer wall of the jacket, is an annular slide-valve, P. This valve has duplicate or opposite heads, which are connected by rods T, arranged to run through the spaces between the ribs B'' and through hubs on the opposite faces of said heads. These rods are fitted with screw-threads on their ends, and are furnished with lock-nuts T' to provide for securing the rods and adjustment of the valve or valve-heads relatively to the ports which the latter control. The two heads of the valve P are constructed or provided with suitable packings for their operation in relation with the walls of the annular spaces in which they work. The valve-rods K K, by which the front valve-head P is connected with the arms I' I'' of the rock-shaft I, are secured to the outer face of said front valve-head in like manner as the rods T.

The cylinder-heads N N are constructed to project inwardly from their flanges, and to stop short of the ends of the cylinder B', and each of said heads made of varying diameter to obtain two cylindrical shoulders, *a* and *b*, one (*a*) of which is set off a short distance from the inner face of the flange on the end of the cylinder, and the other (*b*) of which is formed by a ring, V, which constitutes the smaller protruding portion of the cylinder-head. By the shoulder *a* the cylinder-head is properly guided and held centrally within the end of the cylinder. The inner and smaller portion of the cylinder head or ring V, attached thereto, is of a corresponding diameter with the outside of the cylinder B', but stops short of the end of the latter to form steam-ports thereto. Said ring is reduced on its face to something less than the bore of the cylinder B', which reduced portion and inner surface of the ring opposite the end of the cylinder B' is made tapering or conical. The engine-piston Q works, when at the end of its stroke, close up to such inwardly-protruding portion of the ring. Either end of the cylinder B' is also of a tapering or conical form, but in reverse direction to the conical surface of the ring V, thereby leaving an annular tapering space, *d*, between the ring V and the end of the cylinder B'. Said ring V is provided with landings or projections *e* on or around it. These landings meet the conical faces of the end of the cylinder B' and of the head N, but leave an annular space between said ring and the head of the end of the cylinder. The space between the ring and the head of the cylinder is made considerably larger than that between the ring and the end of the cylinder. The latter of these spaces forms the induction-port *g*, and the former of them an exhaust-port, *h*, to and from the cylinder. The area of said spaces *g* and *h*, being distributed over or around the inner end of the cylinder, admits of said spaces being of very restricted dimensions relatively to the length of the cylinder, to obtain a quick or free inlet and escape for the steam during a rapid motion of the engine, and but a very limited stroke of the valve P is necessary to close and

open the ports. By employing separate larger ports *h* for the eduction of the steam, back pressure is avoided in the rapid running of the engine.

The rings V are connected with the heads N, so as to leave a communicating passage between them and the annular space formed by the jacket R outside of the cylinder B', to allow the exhaust-steam to pass through or within the cylinder-heads, thereby reducing condensation of the steam in the cylinder.

By the construction of the parts, as described, it will be observed that the seat for the valve P is formed partly on the cylinder-head. This not only facilitates the construction of the valve-seat, but reduces the amount of space necessary at the end of the annular steam-chest, thus rendering a shorter cylinder admissible and reducing the amount of turning or fitting. The cylinder-head is only fitted into the jacket, and the valve P makes the joint between the annular steam-chest and the cylinder-head.

W is the inlet for the live steam to the jacket. The exhaust-steam passes, by enlarged end ports *k*, into a chamber or box, *x*, under the bottom of the cylinder, and from thence escapes by a suitable outlet.

By the inclosure of the working-cylinder by steam-spaces at its sides and ends, not only is condensation reduced, but a uniform heating of the cylinder is obtained, and all injurious displacement of the valve-seats and other parts is avoided.

A cam, M, through or by means of the rod L and a yoke on the outer end of said rod, may be used to move the valve P; but it is preferred to employ steam-pistons *o' o'* for the purpose, and simply to use the cam to lock and unlock the valve, and thereby to control the motion of the valve. These pistons *o' o'* are connected by rods *s* (see Fig. 4) with the back head of the valve P, and work in cylinders O O at the rear end of the engine-cylinder, and are controlled by passages *t* connecting the annular seat of the valve P with the cylinders O O. Apart from this combination of the auxiliary pistons *o' o'* and their cylinders O O in direct line and in combination with the annular valve P and the chamber or space in which said valve works, no claim is made in this application to the valve-gear, which latter may be variously changed.

In further explanation of the auxiliary pistons *o' o'* and their cylinders O O, it may be observed that the area of the rear head of the valve P is such as to insure the movement of the valve backward by the pressure brought to bear on the opposite end of the valve when the cam M is adjusted to admit of such movement. The forward motion of the valve P is obtained by means of the pistons *o' o'*, the area of which is sufficient to insure an excess of pressure on the valve to move it in a reverse direction so soon as the cam M permits of such movement.

To obtain a cut-off action to the valve P,

the cam M may be arranged to slide on the main shaft, and be adjusted either by hand or by the engine-governor, and be suitably constructed to vary the period of its releasing action of the valve.

I claim—

1. The combination, with the double-headed annular valve, the annular steam chest or jacket in which said valve works, and the engine-cylinder, of the cylinder-covers, constructed to partly form the valve-seat, substantially as specified.

2. The combination, with the cylinder-heads N and the cylinder B', of the rings V on the inner faces of the cylinder-heads, constructed to leave an exhaust-passage between them and the outer portions of said heads, and to form tapering ports *g h* at the ends of the cylinder, essentially as described.

3. The combination of the cylinder B', the jacket R', the cylinder-heads N, the rings V, constructed to leave an exhaust-passage between them and the outer portions of said heads, also to form tapering ports *g h* at the ends of the cylinder, and the double-headed annular valve P, substantially as specified.

4. The combination of the pistons *o' o'* and their cylinders O O with the double-headed annular valve P, the cylinder B', its heads N, and the ports *g h*, essentially as described.

In witness whereof I hereunto set my hand this 25th day of January, 1877.

JAMES G. COOPER.

In presence of—

B. R. WELLS,

R. BOCKLEY.