

M. H. PEARSON.
Waxing-Device for Sewing-Machines.

No. 199,991.

Patented Feb. 5, 1878.

Fig. 1.

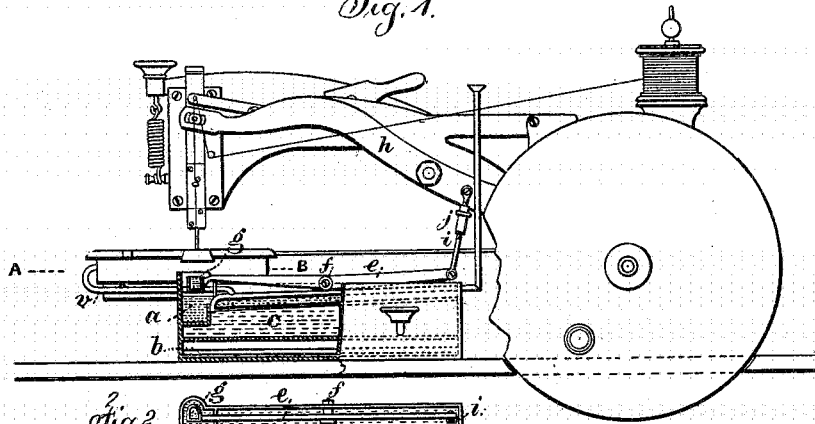

Fig. 3.

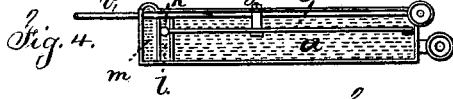
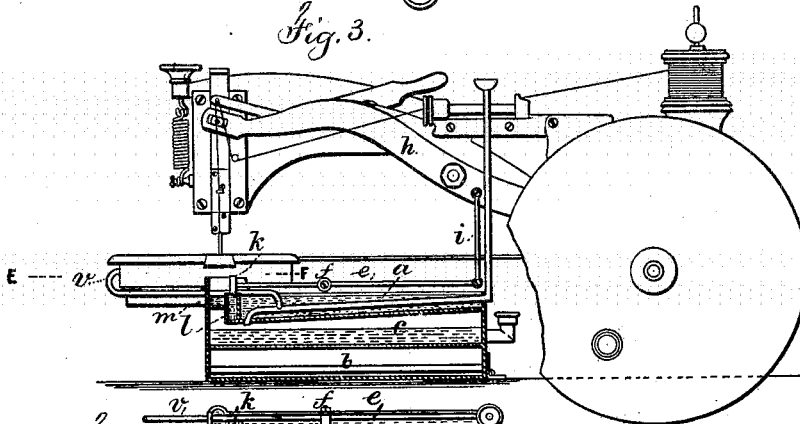
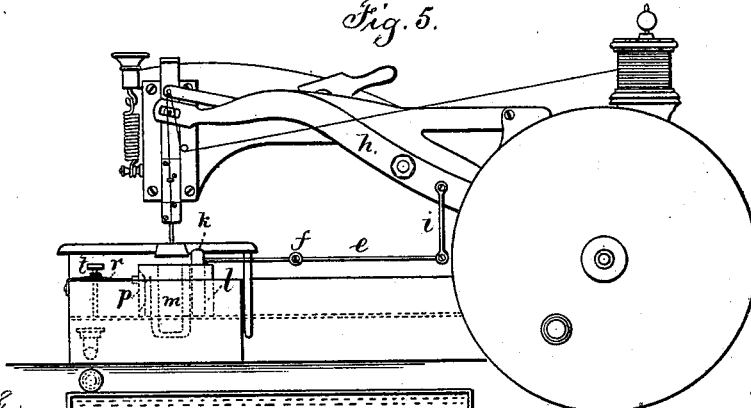
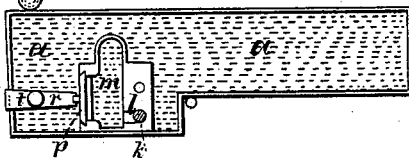

Fig. 5.



Witness
Charles Smith
Geo. S. Parckney

Fig. 6



Inventor
M. H. Pearson.
per Lemuel W. Serrell atty.

UNITED STATES PATENT OFFICE.

MARSHALL H. PEARSON, OF LEEDS, ENGLAND.

IMPROVEMENT IN WAXING DEVICES FOR SEWING-MACHINES.

Specification forming part of Letters Patent No. **199,991**, dated February 5, 1878; application filed June 4, 1877.

To all whom it may concern:

Be it known that I, MARSHALL HENRY PEARSON, of Leeds, in the county of York, England, have invented new and useful Improvements in Waxing Devices for Sewing-Machines, which improvements are fully set forth in the following specification.

The object of my invention is to make all shuttle-sewing machines capable of sewing with hard-waxed or bees-waxed thread.

In the drawings, Figure 1 is a partial side elevation and section of my invention as applied to a sewing-machine, and Fig. 2 is a sectional plan of the same at the line A B.

Below the lowest point of the needle, when at its extreme dip, I place a bath, *a*, of wax, its position being so arranged that when it is full of wax the surface of the wax is well below the point of the needle. In order to keep the wax in a molten state I provide the gas-jets *b* or their equivalents. These may be regulated by any ordinary means, but in order not to burn the wax I provide, between the bath *a* and jets *b*, a tank, *c*, containing water.

e is a lever, which is carried on the stud *f* on the bed of the sewing-machine. On one end of it is provided the small cup *g*.

To the lever *e* is imparted a radial movement, this being obtained from the side lever *h* (or from any other convenient source) through adjustable rod *l*, which may be varied in length by means of the nut *j*. The motion given to the lever *e* is to lift the cup *g* from the bath *a*, which cup *g* has previously received a supply of wax therefrom by being dipped into the bath *a*.

This cup *g* is lifted sufficiently high that the needle passes into the wax contained therein up to within a short distance from its eye, and, on being withdrawn, a portion of the wax adheres to it, filling the grooves thereof with hot wax. The needle then rises into the leather, and the wax in its grooves is removed by friction, and left therein. The threads being now drawn into the same, are perfectly waxed, and the holes are also filled with wax. As soon as the needle begins to lift, the lever *e* carries its small cup *g* into the bath *a* below, to be replenished with hot wax. The rod *i* is varied in length, to suit the quantity of wax in the bath *a*.

Another modification is shown in Figs. 3 and 4, in which Fig. 3 is a partial side elevation and section, and Fig. 4 a sectional plan at the line E F, Fig. 3. This arrangement is very similar to that described in the first part of my invention; but instead of having a cup at the end of the lever *e*, as shown in Fig. 1, I provide a small ram, *k*, at the end of said lever *e*, within the cylinder *l*, and arranged in a similar manner to a small ordinary pump provided with necessary valves. Movement being given thereto, draws the molten wax from the tank or receiver *a*, and deposits it in the cup or bath *m*, into which the needle dips in the manner hereinbefore described. The other parts are similar to those before described.

A further modification is shown in Figs. 5 and 6, of which Fig. 5 is a side elevation, and Fig. 6 a plan, of the tank shown in Fig. 5. The arrangement is very similar to that described in Figs. 3 and 4.

I provide the small ram *k*, which is worked by means of the lever *e* within the cylinder *l*, as described with reference to Figs. 3 and 4, and movement is given thereto in a similar manner, for drawing up the wax from tank *a* and depositing it in a larger bath, *m*, than that shown in Figs. 3 and 4.

In order to regulate the height or quantity of molten wax in the bath *m*, I provide the adjustable dam-plate *p*, which may be raised or lowered at pleasure by means of the spring *r* acting thereon, and regulated by means of the set-screw *t*. I also lessen the adhesion of the wax upon the shuttle, and render the tension of the shuttle-thread more uniform by warming the shuttle by a jet of steam directed upon it, which not only softens the wax by the warmth, but also moistens the parts of the shuttle and shuttle-holder, so that the wax does not adhere thereto.

The steam may be obtained from any suitable source. It is preferable to introduce a steam-pipe at the upper part of the water-bath, as seen at *v*, Figs. 1, 2, 3, and 4, and convey the same to the end of the shuttle raceway, where it terminates with a jet-nozzle, so that a small jet of steam shall pass constantly into the raceway and around the shuttle.

I claim as my invention—

1. The combination, with the sewing-ma-

chine and the wax-holder, of a lifting device for the wax, consisting of a cup or pump, and mechanism for connecting the same to the operating parts of a sewing-machine, whereby the said wax-lifting device is raised and lowered at every reciprocation of the needle, and caused to present the melted wax with uniformity for the needle to enter the same, substantially as set forth.

2. The method herein specified of warming the shuttle of the sewing-machine and lessening the adhesion of the wax by directing upon such shuttle a jet of steam to warm and moisten the same, substantially as set forth.

MARSHALL HENRY PEARSON.

Witnesses:

JOSEPH WILLIAM HARDING,

WM. FAIRBURN HART.