

G. S. PECK.  
Mowers.

No. 199,992.

Patented Feb. 5, 1878.

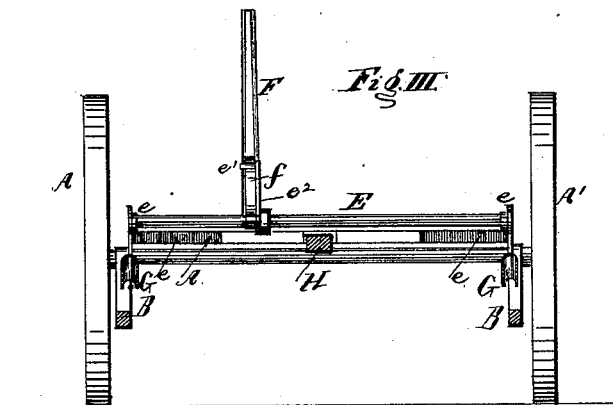
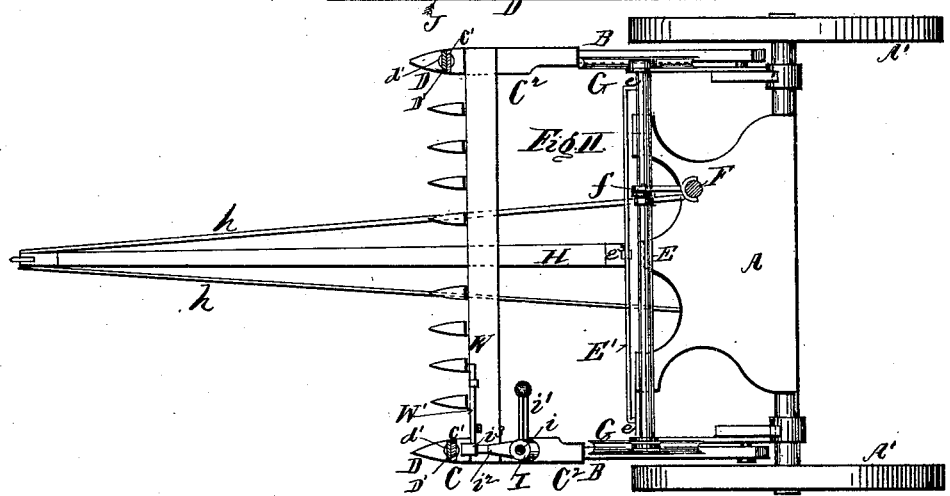
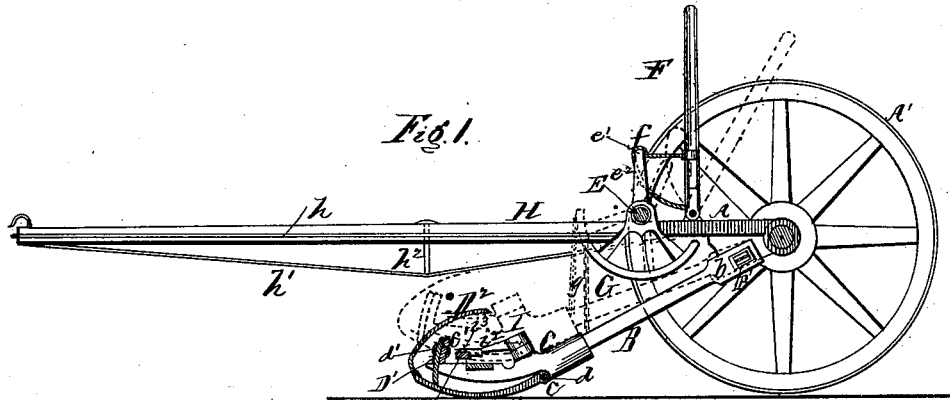

Witnesses:  
*J. Carritt*  
*Edwin B. Jennings*

Inventor:  
*Genl S. Peck*  
 Per *Henry Gannett*  
 Attor.

G. S. PECK.  
Mowers.

No. 199,992.

Patented Feb. 5, 1878.

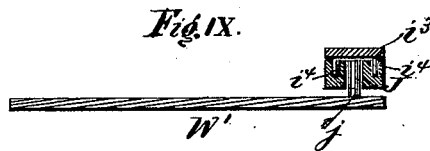
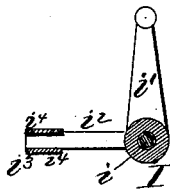
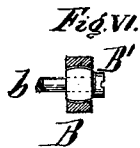
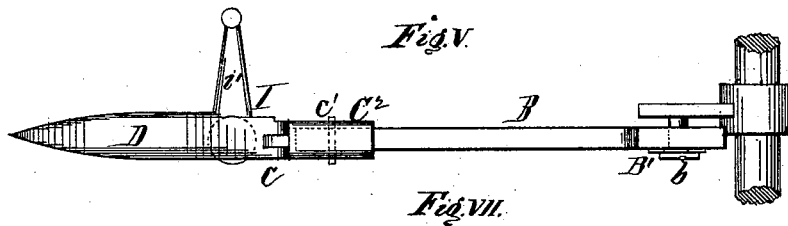
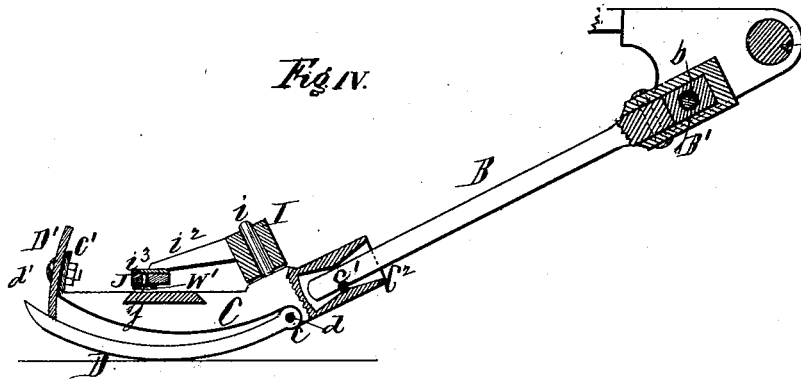

Witnesses:  
*F. Davitt*  
*Edwin B. Jennings*

Inventor:  
*George S. Peck*  
 Per: *Henry Gomer*  
*Atty.*

# UNITED STATES PATENT OFFICE.

GEORGE S. PECK, OF TOWANDA, PENNSYLVANIA.

## IMPROVEMENT IN MOWERS.

Specification forming part of Letters Patent No. 199,992, dated February 5, 1878; application filed May 11, 1877.

*To all whom it may concern:*

Be it known that I, GEORGE S. PECK, of Towanda, in the county of Bradford and State of Pennsylvania, have invented a new and useful Improvement in Mowing-Machines, of which the following is a specification:

This invention relates to a direct or center draft machine; and the nature of the invention consists of improvements in the foot-piece to which the cutter-bar is attached, and in the flexible connections of the same with the fixed frame of the machine; also, to the mechanism for raising and lowering the cutter-bar, and the device for operating the cutter-bar.

The invention will be readily understood by reference to the accompanying drawings, of which Figure I is a side elevation of the improved machine, showing in full lines the cutter-bar down upon the ground as in use, and in dotted lines the cutter-bar raised up as when out of use. Fig. II is a general plan of the same. Fig. III is a transverse sectional elevation of the machine, taken in front of the raising shaft and lever, and looking toward the rear of the machine. Fig. IV is a longitudinal sectional elevation of one of the sliding foot-pieces and its attached connecting-rod, with the swivel bearing-block at the top end of said rod. Fig. V is a bottom plan of the parts shown in Fig. IV. Fig. VI is a transverse section of swivel bearing-block shown in Fig. IV, taken through the center of its attaching-screw. Fig. VII is a bottom plan of the cutter-bar vibrator, showing the two flanges on the bottom part of the driver-head. Fig. VIII is a top plan of the sliding block that fits into and slides on the flanges of the driver-head shown in Fig. VII. Fig. IX is a detail sectional elevation of a portion of the cutter-bar, with the sliding block and driver-head shown in Figs. VII and VIII.

The machine is attached to a fixed frame, A, which is mounted on wheels A' in the usual manner of harvesters and mowers. The frame A may be wholly of cast-iron, in one piece. To the outsides of the frame A attachments are made (in a manner hereinafter more fully described) for the connecting-rods B, which carry on their lower or forward ends the blocks or foot-pieces C, to which is attached the cutter-bar W.

The cutter-bar W is fixed rigidly to the block

C, and the height of it is adjusted to suit the required height of cut by means of the shoe-piece D.

The back end of the shoe-piece is hinged to the lug *c* (formed on the bottom side of the block C) by means of the pin *d*, so as to allow the front part of the shoe to rise and fall, relatively, on the said pin *d*, as on a pivot.

To the top side of the shoe-piece, near its front end, is fixed a stud, D<sup>1</sup>, which rises just in front of the stud C<sup>1</sup>, formed on the extreme front end of the block C, as shown in Figs. I and IV.

A screw-bolt, *d'*, connects the stud D<sup>1</sup> to the stud C<sup>1</sup> when the parts are assembled, and several holes are made in the stud D<sup>1</sup>, so as to attach these parts together at different elevations for the purpose of regulating the position of the end of the block C and the cutter-bar at different heights, so as to regulate the height of cut to suit.

In order to allow either end of the cutter-bar, independently of the other end of it, to rise over elevations of or obstructions upon the ground, or to fall into depressions, I attach the top end of the connecting-rods B to the frame A by means of a swivel-block, B', and the bottom end of it to the block C by means of the vibrating joint C<sup>2</sup>. (Shown clearly in the detail view of Fig. IV.)

The joint C<sup>2</sup> consists of a mortise made in the rear end of the block C, the said mortise being formed with its ends wider than its central part, as shown in Fig. IV, the top and bottom of the mortise being formed to fit the top and bottom of the rod B, a semicircular form being preferable.

A pin, *c'*, fastens the rod B to the block C, while the enlarged ends of the mortise C<sup>2</sup>, as above described, permit the free play of the joint up and down, as is required, when the machine is moving over uneven surfaces of the field.

The swivel-block B' permits a twisting of the parts as one end of the cutter-bar rises or falls without injury, and without undue strain or wear upon any of the surfaces or parts of the machine. This block is clearly shown in Figs. IV and VI. It consists of an elongated piece, having semi-cylindrical surfaces at top and bottom, and flattened sides.

The seat made in the rod B for the block

B' is of the required length to neatly and easily receive the same. The upper and lower parts of the seat are made to fit accurately the upper and lower curved surfaces of the block B, so that it may roll laterally in the seat as the rod B is twisted to one way or the other.

A hole through the center of the block B' permits the screw *b* to pass through it and attach it to the frame A. The rod or shaft E is placed across the front part of the frame A, to which it is attached by suitable bearing-boxes *e*, and is used to raise or lower the front ends of the rods B and the cutter-bar by means of the lever F, the said lever being placed near the center of the machine, and in convenient proximity to the driver's seat.

The lever F has a segmental arm, *f*, which engages the wrist-pin *e'* of the shaft-arm *e''*, so as to act as a segmental lever, as shown in Fig. I. The shaft E is strengthened by means of the truss-rod E', which rises over the stud *e''* in its central part, and is attached at its ends to the bearing-boxes *e*, the arrangement being such as to hold up the bearings of the shaft and permit the use of a very light rod for this purpose. To the outer ends of the shaft E are attached two sectors, G, which have grooved peripheries, in which lie the hoisting-chains *g g*. The upper ends of these chains are attached to the upper ends of the said sectors, and the lower ends to the rods B.

When the shaft E is rotated rearward by means of the lever F, the sectors G roll over so as to wind the chains *g* up and raise the front ends of the rods B, and with them the cutter-bar.

The pole H, to which the draft-team is attached, is trussed on the sides by two rods, *h*, and on the bottom by one rod, *h'*, and a central bearing-stud, *h''*, the top end of the said stud being arranged to press up against the central part of the pole. The front ends of the rods *h h* and *h'* are attached to the front end of the pole H, and the rear ends of these to the frame A and the rear end of the pole H, respectively. By the use of these rods a much lighter pole may be used than otherwise could be employed.

To the front ends of the shoes D are attached steel guard-rods D<sup>2</sup>, for the purpose of dividing the grass and throwing it into the

proper position. These rods extend from the front ends of the shoe-pieces up over and to the rear of the cutter-bar, where they abruptly terminate, as shown in Fig. I.

The cutter-vibrator I is pivoted to one of the foot-pieces C by the pin *i*, as shown in the general drawings. This vibrator consists of two arms, *i'* and *i''*, set at right angles to each other, and united to a common hub, through which the pin *i* passes. On the outer end of the arm *i'* is a ball, which forms a part of a ball-and-socket joint for the connection of the pitman that operates it. The pitman is not shown, but will communicate motion from the driving wheel or axle in the usual manner of mowers.

The outer end of the arm *i''* is enlarged into the driver-head *i'''*, the bottom side of which is shown in Fig. VII, exhibiting in said figure two downwardly-projecting flanges, *i'''*, between which is fitted and easily moves the sliding block J. (Shown in Fig. VIII.) Two grooves in the top face of the block J receive the flanges *i'''*.

As the vibrator-arm *i''* is moved back and forth in a reciprocating manner, the block J is carried with it by means of the flanges *i'''*, and yet the block J is permitted free play to slide on the flanges, either toward or from the pivot-pin *i*, as is required, by reason of the segmental path traveled by the driver-head *i'''* and the rectilinear path traveled by the block J, which is coupled to the end of the operating cutter-bar W' by means of a single round pin, *j*.

Having described my invention, I claim—

1. The vibrating joint C<sup>2</sup> and the swivel-block B, with flattened sides and semi-cylindrical top and bottom, in combination with the block C, rod B, screw *b*, and frame A, substantially as and for the purpose set forth.

2. The cutter-vibrator I, having the arms *i'* *i''*, and the driving-head *i'''*, with flanges *i'''*, in combination with the block C, to which it is attached by pin *i*, the sliding block J, and cutter-bar W', substantially as and for the purpose set forth.

GEORGE S. PECK.

Witnesses:

GEO. S. ESTELL,  
CHAS. L. CODDING.