

D. RHODES.
Harrow.

No. 199,995.

Patented Feb. 5, 1878.

Fig. 1.

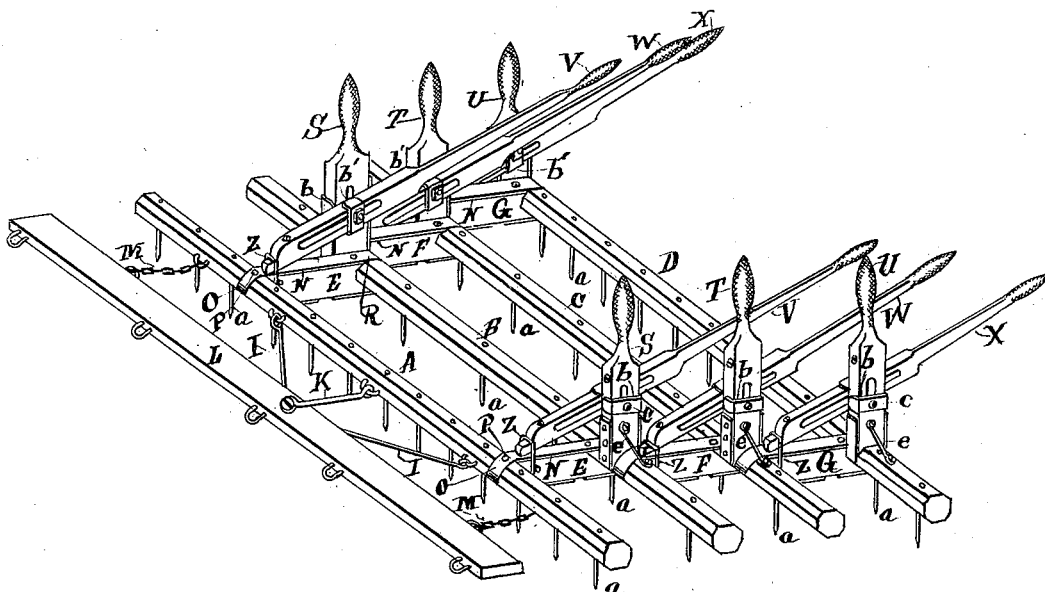
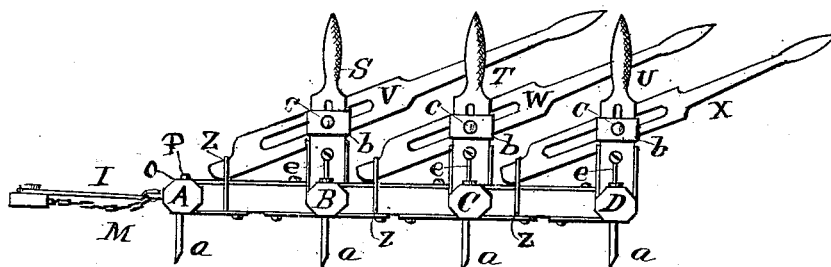

Fig. 2.



Witnesses
J. A. Fauberschmidt
G. Chatterton.

Inventor
David Rhodes.
By Theodore Mungen, Attorney

UNITED STATES PATENT OFFICE.

DAVID RHODES, OF FREDERICKTOWN, MISSOURI.

IMPROVEMENT IN HARROWS.

Specification forming part of Letters Patent No. **199,995**, dated February 5, 1878; application filed January 2, 1878.

To all whom it may concern:

Be it known that I, DAVID RHODES, of Fredericktown, in the county of Madison and State of Missouri, have invented certain new and useful Improvements in Harrows; and I do hereby declare that the following is a full, clear, and exact description of the same, reference being had to the accompanying drawing, making a part of this specification, in which—

Figure 1 is a view in perspective, and Fig. 2 is a sectional elevation of a harrow embodying the improvements of my invention.

This invention relates to certain improvements in harrows; and consists in the improvements in the construction of the same hereinafter more fully described, and particularly pointed out in the claim.

The harrow-frame consists of the beams A, B, C, and D, provided with teeth *a*, and connected by side bars E, F, and G. To the front beam A is articulated, by braces I, I, and K, the draft-bar L, to which the motive-power is attached. Chains M are used to equalize the draft upon the bar L. The side bars E, F, and G are bound with metallic strap N, to strengthen them, and also to furnish bearings for the adjustment and articulation of the beams before mentioned. The front bearings O of the side bars E are fixed to the beam A by having bolts P driven through them into said beam, so that the said beam has no motion within the bearings O. The rear bearings R of the side bars E are let into recesses in the beam B, and permit the beam B to be adjusted as hereinafter described. Both the front and rear bearings of the side bars F and G are let into the beams B, C, and D in a manner similar to that described as applying to the rear bearings of the side bars E, so that the said beams B, C, and D may be both adjusted and articulated by the means hereinafter described. Slotted fulcrums S, T, and U are rigidly connected to the beams B, C, and D. Slotted levers V, W, and X, having their weight ends secured by vertical loops Z rising from the side bars E, F, and G, are secured through the medium of sliding clasps *b* *b'* and bolts and nuts *c*.

When the teeth *a* are vertical, the fulcrums

S, T, and U are also vertical. The teeth *a* may be turned either forward or backward by loosening the nuts and bolts *c*, and sliding the clasps, bolts, &c., either forward or backward upon their respective slotted levers, which operation will carry those of the clasps upon the slotted fulcrums up or down upon the same, as the case may be.

It will be seen that the front beam A is regulated by the motive-power attached to the draft-bar L, and that the harrow at all times presents a square front to its work.

As before said, the beam A is rigidly fixed in its bearings O, but the bearings of the beams B, C, and D permit them to be both adjusted and articulated within the same. The adjustment is for the purpose of presenting the teeth *a* at different angles to the soil, in order that it may be effectually pulverized. The articulation is for the purpose of permitting the beams A, B, C, and D to be raised to clear obstructions, or to clear the teeth *a* of the trash which may have accumulated upon them; and this latter operation is performed by bearing down upon the levers V, W, and X, to raise the beams A, B, and C, and by lifting upon the levers X to raise the beam D, while the former operation of adjusting the beams and teeth is performed by sliding the slotted fulcrums S, T, or U either forward or backward upon the slotted levers V, W, or X, and securing them in position by the bolts and nuts *c*.

It will be observed that by removing the nuts and bolts *c* and withdrawing the levers V, W, and X from their loops Z, that the harrow-frame may be folded for storage or transportation, the teeth being turned inwardly. The sliding clasps *b* are placed directly beneath the heads of the bolts, and slide, when adjustment is made, upon the slotted fulcrums S, T, and U; and the clasps *b'* are placed directly under the nuts of the bolts *c*, and slide upon the levers V, W, and X. The fulcrums S are fixed to the beam B, between the rear bearings of the side bars E and the front bearings of the side bars F, the bearings of the side bars E being upon the inner sides and those of the bars F upon the outer sides of the fulcrums S. The fulcrums T are fixed to

the beam C upon the outer sides of the rear bearings of the side bars F, and the fulcrums U to the beam D upon the outer sides of the bars G. The series of slotted levers V, W, and X are secured, as shown, to the inner sides of their respective fulcrums, so that in operation there is no interference between the said levers. A series of braces, *e*, connect the fulcrums with their respective beams, and strengthen the fulcrums.

It will be seen that the teeth *a* in the front and rear beams A and D are placed quite near together, and are more numerous than the teeth in the intermediate beams, the teeth in the latter beams being alternating and farther apart, thus enabling the harrow, when passing over the ground, to thoroughly pulverize it.

Having thus described my improvements, what I claim as new and useful, and desire to secure by Letters Patent, is—

1. In a harrow-frame, the adjustable beams B, C, and D, provided with the uprights or fulcrums S, T, and U, in combination with the slotted levers V, W, and X, whereby the harrow-teeth may be cast forward or backward,

or be held in a perpendicular position, substantially as and for the purposes set forth.

2. A harrow-frame, the adjustable beams of which are provided with the fulcrums S, T, and U, and connected by the side bars E, F, and G, in combination with the slotted levers V, W, and X, whereby each beam is made to act independently of the others, substantially as and for the purposes set forth.

3. In a harrow-frame, the adjustable beams of which are provided with the slotted fulcrums S, T, and U, and connected by the side bars E, F, and G, the slotted levers V, W, and X, secured by the clasps *b b'*, bolts and nuts *c*, and loops Z, to permit the removal of the levers, that the harrow-frame may be folded, substantially as and for the purposes set forth.

In testimony that I claim the foregoing improvements as above described I have hereunto set my hand and seal this 19th day of December, 1877.

DAVID RHODES. [L. S.]

Witnesses:

WILLIAM N. NALLE,
D. W. O. BANNON.