

S. SMITH.
Sliding-Door.

No. 200,001.

Patented Feb. 5, 1878.

Fig. 1.

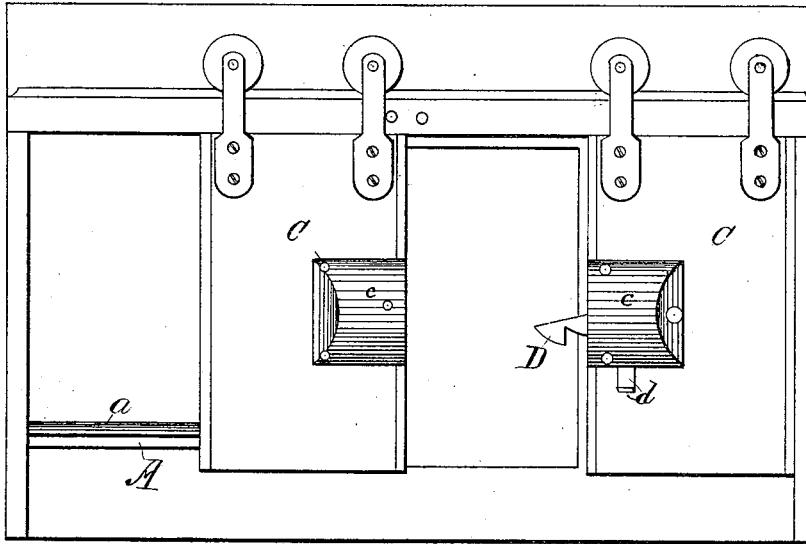
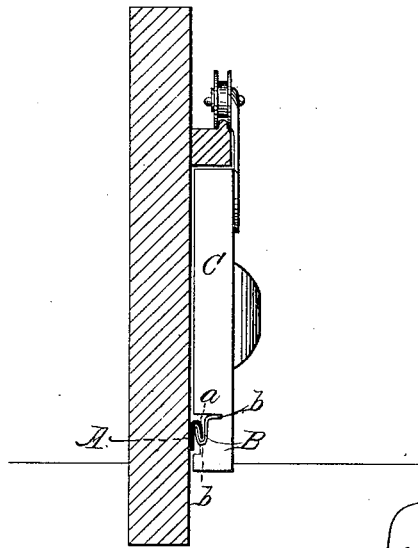

Fig. 2.



WITNESSES

Arthur H. Adams.
Wm. W. Witter.

Silas Smith
INVENTOR

Edson Best.
ATTORNEYS

UNITED STATES PATENT OFFICE.

SILAS SMITH, OF HAMMONDSPORT, NEW YORK.

IMPROVEMENT IN SLIDING DOORS.

Specification forming part of Letters Patent No. **200,001**, dated February 5, 1878; application filed July 21, 1877.

To all whom it may concern:

Be it known that I, SILAS SMITH, of Hammondsport, in the county of Steuben and State of New York, have invented certain new and useful Improvements in Sliding or Rolling Doors; and I do hereby declare that the following is a full, clear, and exact description thereof, which will enable others skilled in the art to which it appertains to make and use the same, reference being had to the accompanying drawings, and to the letters of reference marked thereon, which form a part of this specification, and in which—

Figure 1 is a side view of my improved sliding door. Fig. 2 is a vertical transverse section thereof.

Corresponding parts in the several figures are denoted by like letters.

This invention relates to a certain improvement in sliding doors; and it consists, principally, in the peculiar construction of the guiding-rails for the doors, substantially as hereinafter more fully set forth.

In the annexed drawings, A A refer to rails, one fastened in position to either side of the doorway or opening, and provided with downwardly-projecting lips or flanges *a a*. These flanges or lips *a a* of the said rails or bars enter grooves B B in the inner sides of the doors, to guide the latter as they are slid back and forth in opening and closing the same.

The grooves B B consist, preferably, of plates having horizontal flanges *b*, to secure them in position in the inner sides of the doors, and provided with grooves or gutters *b'*, to receive the flanged portion of the bars or rails A A, and to retain the lower portions of the doors in position. C C are the doors, suitably hung in place by rollers upon overhead-rails, and one having a case, *c*, provided with a socket, and the other a latch or catch, D, which, as the doors are closed, automatically locks the latter. The catch or latch D is provided with a lifting bar or pendant, *d*, by which it may be unlocked or unlatched.

Having thus described my invention, what I claim, and desire to secure by Letters Patent, is—

In sliding doors, the guiding-rail A, having the downwardly-projecting flange *a*, in combination with and entering the groove B in the door or gate *c*, substantially as and for the purpose set forth.

In testimony that I claim the foregoing as my own I hereunto affix my signature in presence of two witnesses.

SILAS SMITH.

Witnesses:

DAVID LONGWELL,
FRANK BRINK.