

T. S. WILES.
Ironing-Machine.

No. 200,011.

Patented Feb. 5, 1878.

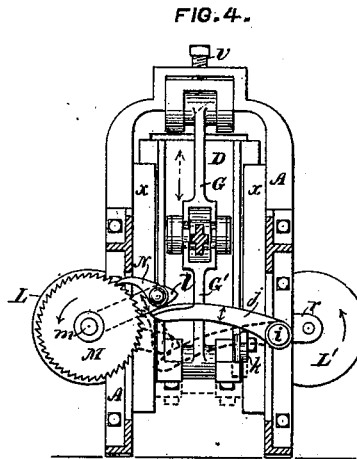
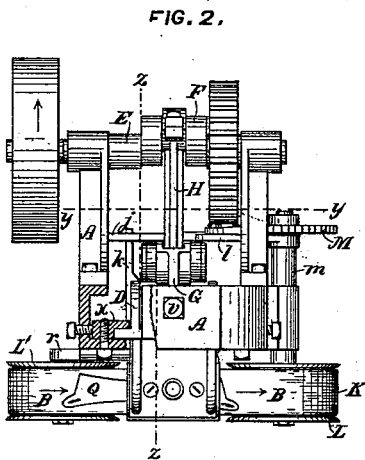
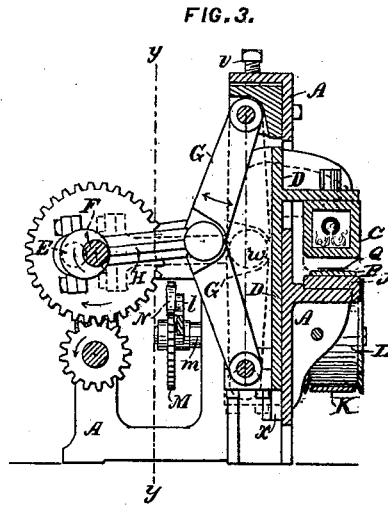
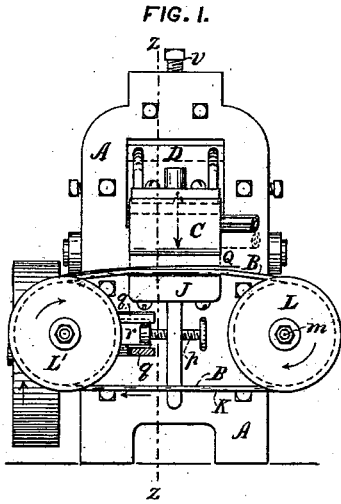

WITNESSES:

Austin F. Park
James T. Goodfellow.

INVENTOR:

Thomas D. Wiles.

T. S. WILES.
Ironing-Machine.

No. 200,011.

Patented Feb. 5, 1878.

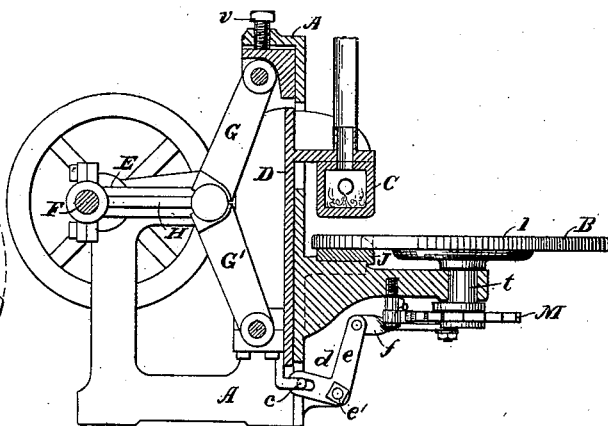
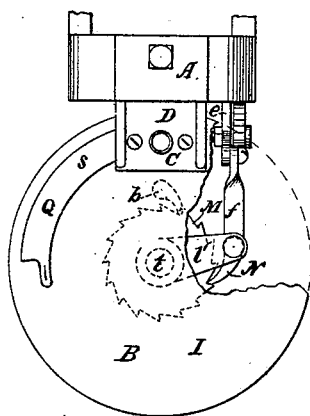
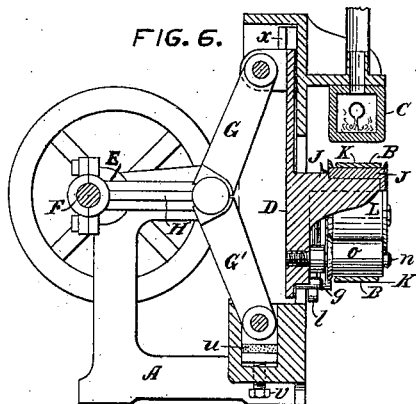
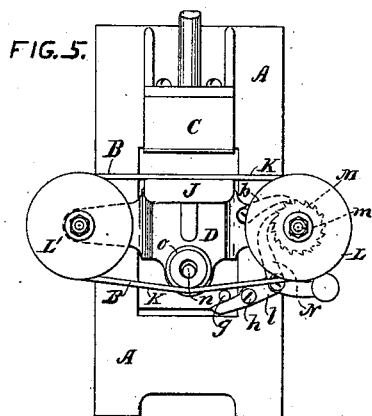

FIG. 7.

FIG. 8.

WITNESSES:

Austin F. Park
James T. Goodfellow.

INVENTOR:

Thomas S. Wiles.

UNITED STATES PATENT OFFICE.

THOMAS S. WILES, OF ALBANY, NEW YORK.

IMPROVEMENT IN IRONING-MACHINES.

Specification forming part of Letters Patent No. **200,011**, dated February 5, 1878; application filed July 21, 1877.

To all whom it may concern:

Be it known that I, THOMAS S. WILES, of the city of Albany, in the county of Albany and State of New York, have invented certain new and useful Improvements in Ironing-Machines, of which the following is a specification, reference being had to the accompanying drawings, in which—

Figure 1 is a front elevation; Fig. 2, a plan, partly in section; Fig. 3, a vertical section at the lines *z z* in Figs. 1 and 2, and elevation of parts on one side of the section; and Fig. 4, a vertical section at the line *y y* in Figs. 2 and 3, and elevation of parts in front thereof, all of an ironing-machine that embodies this invention. Fig. 5 is a front elevation, and Fig. 6 a sectional elevation, showing modifications of the same machine; and Fig. 7 is a broken plan, and Fig. 8 a sectional elevation, of some parts of a machine that embodies a portion of the same invention.

This invention relates to machines by which damp articles of cloth of different thicknesses in different parts can be dried and ironed with a smooth lusterless surface, or "domestic finish," by pressing the articles by and between a heated smoothing-iron and a soft ironing-bed, which will yield and conform to the thick and the thin parts of the articles, and will absorb moisture driven out of the damp articles while being pressed between the ironing-bed and the heated smoothing-iron.

In the aforesaid drawings, in which similar parts are marked by like letters in the different figures, A is the frame which supports the other parts. B is a soft, yielding, and more or less elastic ironing-bed, which can have any suitable support, and can consist of any suitable felted or woven fabric or material, with a surface covering of muslin or other suitable fabric that will absorb moisture given off from damp articles of cloth being ironed on the bed. C is a smoothing-iron, which has a smooth face shaped to fit against the ironing-bed, and which is made of cast-iron or other suitable metal or material, and is to be heated while in use by burning therein jets of mixed gas and air, or by any other suitable means.

In the machinery represented in Figs. 1, 2, 3, 4, 7, and 8, the smoothing-iron C is attached to a carrier, D, which is fitted to be moved to

and fro on or between suitable ways or guides *x* in the frame A, and so that by moving the carrier D in one direction the smoothing-iron will be thereby moved toward and pressed against the ironing-bed B, and by moving the carrier in the opposite direction the smoothing-iron will be separated and removed from the ironing-bed.

In Figs. 5 and 6 the smoothing-iron C is fast on the frame A, and the ironing-bed B is mounted on the carrier D, so as to be thereby moved toward and pressed against the smoothing-iron, and removed therefrom. The pressing, drying, and smoothing action on the damp articles of cloth is the same, whether the smoothing-iron is moved so as to be thereby pressed against and separated from the ironing-bed or the ironing-bed is pressed against and removed from the smoothing-iron.

In ironing damp articles of cloth by pressing the same between a heated smoothing-iron and a yielding moisture-absorbing bed, it is highly important that the articles be pressed by and between the ironing-bed and smoothing-iron during exactly equal and suitable periods of time and with equal force at each pressing-contact, in order to secure a proper uniform drying and smoothing action upon the articles at each successive pressing operation, without liability of scorching or overheating the articles.

To accomplish that object I connect the carrier D of the smoothing-iron or ironing-bed with a rotary driving-shaft by means of a cam, eccentric, crank, and pitman, or other suitable mechanical device, so that the uniform rotation of the driving-shaft shall cause the automatic pressing together and separation of the smoothing-iron and ironing-bed repeatedly at and during uniform periods and intervals, and with the same pressing force at each contact, and so that by changing the rotary speed of the driving-shaft the duration of each pressing together and separation of the smoothing-iron and ironing-bed will be increased or lessened, as shall be desirable, to properly dry and smooth, without scorching, damp articles of different thicknesses.

As a preferred means for securing that result and subordinate advantages, I connect the rotary driving-shaft E with the carrier D

of the smoothing-iron C or ironing-bed B by a crank, F, on the driving-shaft, knee-jointed levers G G', jointed at one end to the frame A and at the other end to the carrier D, and a rod, H, connecting the crank with the genicular levers, substantially as represented in the drawings, so that thereby the uniform rotation of the driving-shaft E shall cause the smoothing-iron and ironing-bed to be pressed one against the other and separated repeatedly with a gradually increasing and decreasing enormous force during a considerable period of time at each contact, so as to thereby compress, dry, and generally finish with a smooth lusterless surface damp articles of cloth placed between the ironing-bed and smoothing-iron, and shall also cause the smoothing-iron and ironing-bed to be separated during a longer interval between each two pressing contacts, so as to permit a person to then conveniently remove the dried and smoothly-pressed article and insert a damp one. I commonly prefer to so construct and arrange the toggle-levers G G', connecting-rod H, and crank F with the rotary shaft E and carrier D that, in pressing the smoothing-iron against the elastic ironing-bed or the ironing-bed against the smoothing-iron, the center joint of the toggle-levers shall pass a little beyond a plane joining the end bearings of the toggle-levers, as indicated at *w* in Fig. 3, whereby the pressure between the smoothing-iron and elastic ironing-bed is considerably increased in duration, with but little variation in intensity. As a means of regulating such pressure, an adjusting-screw, *v*, is arranged, as shown, with or without the intervention of a powerfully-elastic relief medium, *u*, as represented in Fig. 6.

As regards the above-described mechanism, the yielding moisture-absorbing ironing-bed can be larger, or no larger, than the face of the smoothing-iron, and stationary, so that only one and the same portion thereof shall support the damp articles of cloth for the action of the heated smoothing-iron. In such cases that portion of the ironing-bed will commonly soon become so moist that the articles will not be sufficiently dried at one pressing, and consequently the smoothing-iron and moist ironing-bed will then require to be occasionally pressed together and separated without any damp article between them, to thereby quickly dry the bed; and, if the article Q being ironed is larger than the face of the smoothing-iron, such article, after having a part thereof pressed smooth and dried by and between the smoothing-iron and ironing-bed, must be separated from the bed and moved along separately, so as to bring the unpressed part of the article directly between the bed and the smoothing-iron in completing the pressing, drying, and smoothing of the article.

To overcome that defect, I make the ironing-bed of greater extent than the smoothing-iron, and movable, and mount the bed on ways, or in any suitable manner, so that in the

intervals while the bed is not being pressed by the smoothing-iron a person can then easily move the bed, so as to thereby remove from opposite the smoothing-iron that portion of the bed which has just become moist or wet by a damp article having been pressed between it and the smoothing-iron, and in the same act bring a different and drier part of the ironing-bed, with or without an article thereon to be ironed, directly opposite to the smoothing-iron.

As regards the mechanism hereinbefore described, the yielding moisture-absorbing ironing-bed can be in the form of a table, or of any suitable shape and extent. I, however, generally prefer to have the ironing-bed not only of greater area than the face of the smoothing-iron, and movable laterally in respect thereto, but also of a continuous or endless form, so that when it is not in contact with the smoothing-iron a person can then at will readily turn the continuous ironing-bed step by step in its endless direction, so as to thereby bring each successive portion thereof in regular order opposite to the smoothing-iron repeatedly by merely turning the ironing-bed step by step in one and the same direction only; in order that, as each succeeding part of the ironing-bed shall become moist by having a damp article pressed between it and the smoothing-iron, the moisture shall mostly evaporate from each part equally before the same shall be again brought opposite to the smoothing-iron in the rotation of the bed, and in order that a series of suitable damp articles of greater, no greater, or less extent than the face of the smoothing-iron may be successively placed on the continuous bed, and thereby presented and submitted to the action of the smoothing-iron by turning the bed step by step in only one direction.

The continuous ironing-bed can be of any suitable shape, and either fast on or separate from the part or parts by which it is supported against the pressure of the smoothing-iron. In Figs. 7 and 8 the ironing-bed B is in the form of a circular disk, I, having a vertical axis, *t*, about which the bed can be turned by hand or by mechanical devices, and a stationary stock, J, serves to support the bed against the pressure of the smoothing-iron. This circular ironing-bed is generally useful, and is especially suitable for use in ironing collars or articles that are of semicircular form, as indicated at *s* in Fig. 7. I however commonly prefer for general use in ironing articles of various shapes to have the ironing-bed B in the form of an endless apron, K, extended around pulleys L L' and over a stock, J, Figs. 1, 3, 5, and 6, which will support the apron-bed against the pressure of the smoothing-iron C, so that the endless-apron bed can be turned step by step when not in contact with the smoothing-iron by turning one or both of the pulleys L L' by hand or otherwise, and so that the endless-apron bed may form a traveling table-like support for the articles

immediately before and after being submitted to the action of the smoothing-iron.

In Figs. 1, 2, 3, and 4, the pulley *L'* is mounted to turn on a stud that is fast on a slide, *r*, that can be adjusted between guides *q* on the frame *A* by a screw, *p*, so as to thereby give proper tension to the endless-apron bed. In Figs. 5 and 6 a heavy roller, *o*, loosely surrounds a guide-stud, *n*, fast on the slide *D*, and bears on the endless bed *B K*, so as to thereby give tension to the latter.

To avoid generally having a person turn the continuous ironing-bed a step for each pressing together and separation of the ironing-bed and smoothing-iron, I combine with the continuous ironing-bed and the devices by which the ironing-bed or smoothing-iron are pressed one against the other and separated, any suitable mechanism by which the continuous ironing-bed will be uniformly turned a step while not in contact with the smoothing-iron, so as to thereby present equal different portions of the bed, and of any suitable damp article thereon, to the smoothing-iron at and by reason of each pressing together and separation of the smoothing-iron and ironing-bed, however regularly, or irregularly, or by whatever means the smoothing-iron and ironing-bed shall be pressed together and separated.

I commonly prefer to employ for that purpose a ratchet-wheel, *M*, and a driving-pawl, *N*, connected with the continuous ironing-bed and the carrier *D*, substantially as indicated in the drawings.

In Figs. 2, 3, 4, and 5 the ratchet-wheel *M* is fast on the shaft *m* of the pulley *L*, and the driving-pawl *N* is pivoted on a lever, *l*, which, in Fig. 4, is hung on the shaft *m*. In the latter figure the carrier *D* has fast thereon a lug, *k*, which, as the carrier rises, lifts a lever, *j*, that is pivoted at *i* to the frame *A*, and thereby moves the lever *l* with the driving-pawl *N*, and consequently turns the ratchet-wheel *M*, pulley *L*, and endless-apron bed *B K* a step while the smoothing-iron *C* is being moved away from the ironing-bed, and while the carrier *D* with its lug *k* descends the weight of the pawl *N* and levers *l j* moves back the pawl *N*, so as to re-engage the latter with the teeth of the ratchet-wheel preparatory to again turning forward the ratchet and apron-bed as the carrier shall next rise.

In Figs. 5 and 6 the driving-pawl *N* is weighted, and the lever *l*, to which the pawl is pivoted, has a fulcrum at *h* on the frame *A*, and extends under a projection, *g*, on the carrier *D*, so that while the latter descends, in moving the endless bed *B K* with its support *J* away from the smoothing-iron *C*, the part *g* moves the lever *l*, and thereby moves the pawl *N*, so as to turn the ratchet-wheel *M*, pulley *L*, and endless bed *B K* forward a step, and while the carrier *D* rises to press the bed against the smoothing-iron the weighted pawl then falls back to again take hold of other teeth of the ratchet-wheel.

In Figs. 7 and 8 the ratchet-wheel *M* is fast on the shaft *t* of the circular ironing-bed, and the driving-pawl *N* is pivoted on an arm, *l'*, which is hung on the shaft *t*, and is pivoted to a rod, *f*, that is jointed to an elbow-lever, *e*, that is pivoted at *e'* to the frame *A*, and has in one arm a slot, *d*, in which works a pin-lug, *c*, fast on the carrier *D*, so that as the latter is moved upward in removing the smoothing-iron from the ironing-bed the pawl *N* is thereby moved so as to turn the ratchet-wheel *M* and circular ironing-bed a step, and so that the pawl *N* is drawn back to engage with other teeth of the ratchet-wheel by the movement of the smoothing-iron toward the ironing-bed.

In Figs. 5 and 7, *b* is a detent, which, when engaged with the ratchet-wheel, prevents backward movement of the latter.

The devices for automatically turning the ironing-bed step by step while not in contact with the smoothing-iron may be put out of action by disengaging the pawl *N* from the ratchet-wheel *M*, so that the bed *B* can then be turned forward or not at will by a person attending the machine, as is sometimes very important in ironing articles of great or irregular thickness, which require the same part or parts to be repeatedly pressed by and between the heated smoothing-iron and ironing-bed to sufficiently dry and finish the articles. The detent *b* can also be disengaged or left off from the ratchet-wheel *M*, so as to allow a person to move back the ironing-bed to conveniently permit the re-pressing of parts of the articles that shall not have been sufficiently dried and finished by the previous pressing of the same between the ironing-bed and smoothing-iron.

Ironing-machines have been heretofore used with an internally-heated smoothing-iron and a yielding moisture-absorbing ironing-bed combined with a lever, treadle, or like device, by means of which a person could press the smoothing-iron against the ironing-bed and remove the same therefrom at will. In using such machines the degree and duration of each pressing contact, and the consequent drying, compressing, and smoothing action of the smoothing-iron and ironing-bed on damp articles between them, would necessarily vary according to the willful, habitual, or accidental action of the person operating the machine, so that the articles would be liable to be unevenly dried and variously finished or overheated and scorched or injured; and in such machines the smoothing-iron or the ironing-bed was to be moved laterally one along the other, while pressed together, so as to thereby produce a polished surface or a "glossy finish," instead of the smooth, even, lusterless surface or "domestic finish" made by my improved machine by the mere pressing together and separation of the smoothing-iron and ironing-bed automatically at and during uniform periods and intervals, and with equal pressure at each contact.

In ironing-machines heretofore made with a yielding moisture-absorbing ironing-bed of greater extent than the face of the smoothing-iron, and movable laterally in respect thereto, I am not aware that the ironing-bed was ever automatically moved step by step only while not in contact with the smoothing-iron, and to the same extent at each separation of the smoothing-iron and ironing-bed.

What I claim as my invention is—

1. The combination of a yielding moisture-absorbing ironing-bed, a smoothing-iron adapted to be heated while in use, and to fit against the ironing-bed, a carrier, D, a rotary driving-shaft, and mechanism connecting the driving-shaft with the carrier, so that the uniform rotation of the driving-shaft causes the smoothing-iron and ironing-bed to be pressed one against the other, and separated repeatedly at and during uniform periods and intervals, substantially as described.

2. The combination of the smoothing-iron, yielding moisture-absorbing ironing-bed, of greater extent than the smoothing-iron, and movable so as to permit different parts thereof to be presented to the smoothing-iron, the carrier D, rotary driving-shaft E, and jointed levers G G', connected with and operated by the said driving-shaft, substantially as described.

3. The combination of the smoothing-iron, yielding moisture-absorbing ironing-bed of continuous or endless form, and movable so that all parts thereof can be presented in succession and repeatedly to the smoothing-iron by moving the ironing-bed in one direction, the carrier D, levers G G', rotary driving-shaft E, crank F, and rod H, substantially as described.

4. The combination of the smoothing-iron, adapted to be heated, movable moisture-absorbing ironing-bed, carrier by which the smoothing-iron and ironing-bed are pressed one against the other and separated, and devices connecting the said carrier with the ironing-bed, so that the latter is moved a step only

while not in contact with the smoothing-iron by pressing together and separating the smoothing-iron and ironing-bed, substantially as described.

5. The combination of the smoothing-iron, movable moisture-absorbing ironing-bed, rotary driving-shaft E, carrier D, and devices connecting the carrier with the said driving-shaft and ironing-bed, substantially as described, so that the uniform rotation of the driving-shaft causes the smoothing-iron and ironing-bed to be pressed one against the other and separated repeatedly at and during uniform periods and intervals, and the ironing-bed to be moved a step at each pressing together and separation of the smoothing-iron and ironing-bed.

6. The combination of the smoothing-iron C, ironing-bed in the form of an endless apron, K, with supporting-stock J and pulleys L L', rotary driving-shaft E, carrier D, and jointed levers G G', connected with and operated by the said driving-shaft, substantially as set forth.

7. The combination of the smoothing-iron C, ironing-bed in the form of an endless apron, K, with supporting-stock J and pulleys L L', carrier D, ratchet M, and driving-pawl N, connected with and operated by the said carrier, substantially as described.

8. The combination of the smoothing-iron C, endless apron K, support J, pulleys L L', rotary shaft E, carrier D, jointed levers G G', connected with and operated by the driving-shaft, ratchet M, and pawl N, connected with and operated by the said carrier, substantially as described.

In testimony whereof I hereunto set my hand in the presence of two subscribing witnesses this 18th day of July, 1877.

THOMAS S. WILES.

Witnesses:

AUSTIN F. PARK,
JAMES T. GOODFELLOW.