

F. BLACKBURN & V. MOESLEIN.
Straw-Braid Sewing-Machine.

No. 200,022.

Patented Feb. 5, 1878.

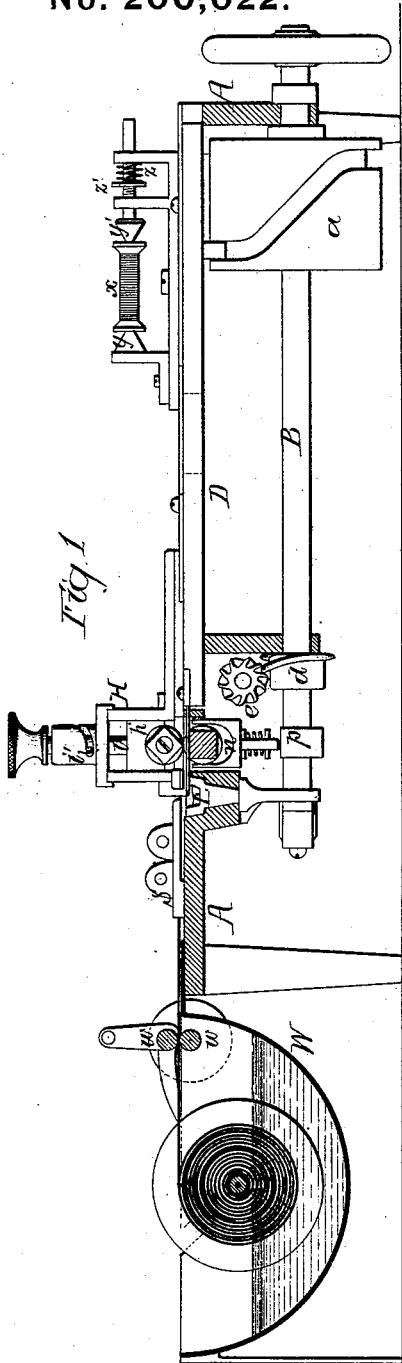

Witnesses
Henry Howson
Henry Smith

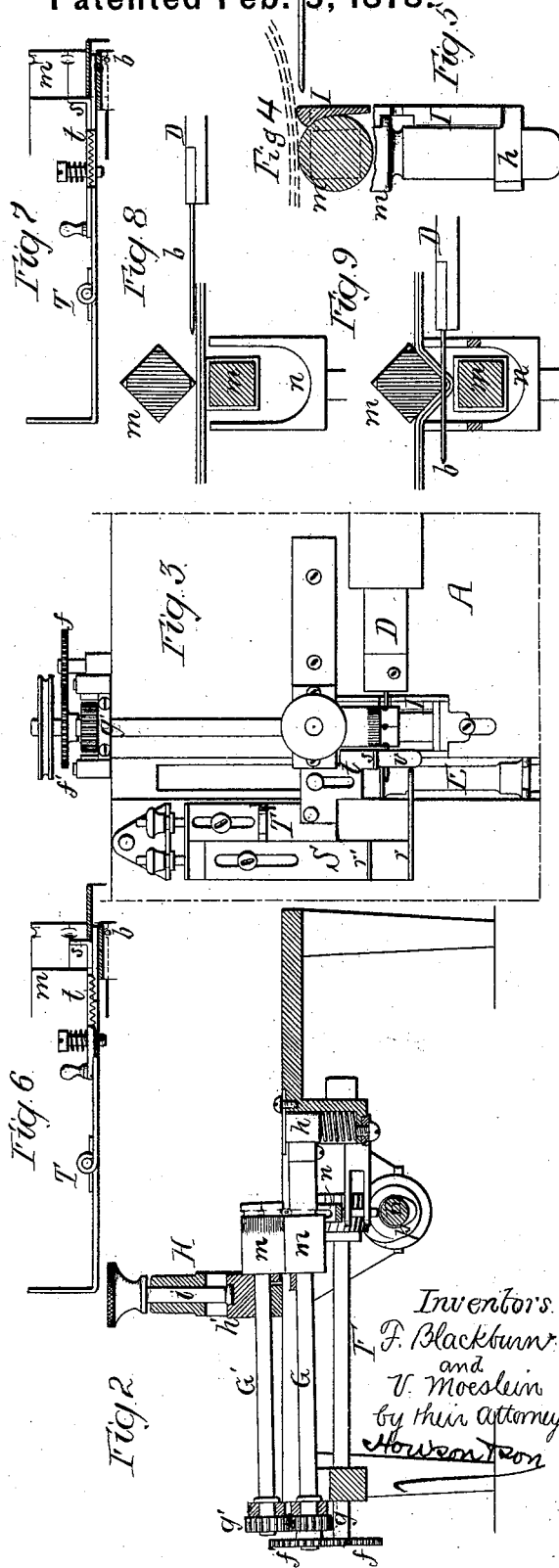

Inventors
F. Blackburn
and
V. Moeslein
by their attorney
Howson

UNITED STATES PATENT OFFICE.

FREDERICK BLACKBURN AND VALENTINE MOESLEIN, OF PHILADELPHIA, PENNSYLVANIA, ASSIGNORS OF THREE-FIFTHS THEIR RIGHT TO HENRY FRIEDBERGER, HENRY L. STROUSE, AND BERNHARD STROUSE, OF SAME PLACE; SAID BERNHARD STROUSE ASSIGNOR TO SAID FRIEDBERGER.

IMPROVEMENT IN STRAW-BRAID SEWING-MACHINES.

Specification forming part of Letters Patent No. **200,022**, dated February 5, 1878; application filed July 28, 1877.

To all whom it may concern:

Be it known that we, FREDERICK BLACKBURN and VALENTINE MOESLEIN, both of Philadelphia, Pennsylvania, have invented a new and useful Improvement in Sewing-Machines, of which the following is a specification:

Our invention relates to certain improvements in machines for sewing straw braid for the manufacture of hats, bonnets, &c., the main object of our invention being to improve the devices for feeding and crimping the braid.

This object we attain in the manner which we will now proceed to describe, reference being had to the accompanying drawings, in which—

Figure 1 is a longitudinal section of our improved straw-braid sewing-machine; Fig. 2, a transverse section of the same; Fig. 3, a plan view, and Figs. 4, 5, 6, 7, 8, and 9, detached views of parts of the machine.

A is the base or frame of the machine, to bearings in which is adapted the driving-shaft B. On the latter is formed a collar, *a*, having a cam-slot, to which is adapted a pin on a bar, D, adapted to guides in the table, and carrying a needle, *b*, a longitudinally-reciprocating movement being thus imparted to the needle-bar and needle as the shaft B revolves.

E is the shuttle-race, which extends transversely across the machine, the shuttle-carrier being reciprocated from the shaft B through the medium of a suitable connecting-arm. To the shaft B is secured a hub, *d*, on which are formed a rib and teeth so constructed and so adapted to the teeth of a wheel, *e*, on the inner end of a transverse shaft, F, as to impart an intermittent movement to said shaft and lock it between its movements.

As this device will form the subject of a separate application for a patent, a detailed description of it here will be unnecessary.

The shaft F serves, through the medium of cog-wheels *f f'* and *g g'*, Figs. 2 and 3, to impart motion in contrary directions to two shafts, G G', both of which are adapted to pivoted bearings at the rear end, the front end of the shaft G being adapted to a spring-box, *h*, and the front end of the shaft G' to a box,

h', adapted to guides in a standard, H, secured to the frame of the machine. The box *h'* has a stem, *i*, from which projects a pin, *i'*, adapted to a curved slot in an extension of the standard H, so that by turning said stem *i* the box *h'*, and with it the front end of the shaft G', may be raised or lowered. Each of the shafts carries a feed-wheel, *m*, these feed-wheels being reduced at the front ends, so as to form angular extensions, which are square in the present instance, but which may be made triangular or otherwise, if desired. The extensions of the feed-wheels are recessed at the edges for the passage of the needle, as shown in the drawing.

To guides beneath and in line with the feed-wheels is adapted the stem of a forked plate, *n*, having arms which embrace the lower feed-wheel, a vertical reciprocating motion being imparted to this plate *n*, in the present instance, by a cam, *p*, on the driving-shaft B.

To the bearing of the lower shaft G is secured a plate, I, which extends along that side of the lower feed-roll *m* which is adjacent to the needle-bar, and bears the relation to the feed-roll shown in the sectional view, Fig. 4, and plan view, Fig. 5. This plate I has a recess in its upper edge for the passage of the needle, so that the braid, after it has been sewed, is caused to pass over this plate, and be thereby lifted out of the way of the needle and needle-bar, and also prevented from being carried round by the lower feed-roll. As the plate I is carried by and moves with the bearing of the lower feed-roll, its position in relation to the latter is always the same.

S and T are the usual plates for guiding the braid, the latter, as it is fed to the machine, passing first between lugs *r r'* on the guide S, and thence under the projecting finger *v* of the guide T to the feed-rolls. The upper layer of braid—that is, the outer layer of the circular mat which is being sewed—abuts against a lug, *s*, on a plate, *t*, carried by the guide T, and overlaps the lower layer, the amount of overlap of the two layers of braid being determined by the position of the lug *s* in respect to the feed-rolls. Hitherto the lug

s has been formed directly on the guide-plate; but this plan necessitates the stoppage of the machine and the change in the position of the entire guide whenever a change in the amount of overlap of the braid becomes necessary—for instance, in passing from the crown to the side, or from the side to the rim of the hat.

In order to prevent the extra labor and loss of time which this demands, we make the plate *t* carrying the lug *s* adjustable on the guide, the upper surface of which and the under surface of the plate are toothed or roughened, the two roughened faces being kept in contact by a spring, so that, while the plate can be readily shifted by applying the requisite pressure to the same, accidental movement will be prevented. The movements of the plate *t* will be readily understood by reference to Figs. 6 and 7, which show said plate in its two extreme positions.

All straw-braid sewing-machines, as heretofore constructed, are objectionable on account of the frequency with which the reel of braid has to be removed from the machine in order to be steeped or steamed, so as to retain the proper degree of dampness for successful working.

In order to obviate this necessity for removing the braid-reel from the machine, we secure to one end of the base Δ a water trough or receptacle, *W*, to bearings in the ends of which the shafts of the braid-reel are adapted, the water being kept at such a height that the braid is always immersed in the same.

The braid passes from the reel between two rollers, *w w*, which are driven from some moving portion of the machine, so as to deliver the braid to the feed-rollers *m* at the proper speed. The rollers *w w* also serve to express the surplus moisture from the braid and deliver the same in the proper moist condition.

It is not necessary that the braid-reel should be submerged in the water, as it may be arranged above the receptacle, the braid passing from the reel around a roller below

the level of the water in the receptacle before passing to the rollers *w*.

In order to prevent too free delivery of the thread from the bobbin *x*, we hang the same between two pivots, *y y'*, the former of which is fixed, but the latter adjustable, its pressure upon the bobbin being regulated by a spring, *z*, which acts upon a nut, *z'*, carried by the stem of the pivot, so that by adjusting this nut the pressure of the pivot upon the bobbin, and consequently the tension upon the thread, can be accurately governed.

The action of the forked plate *n* will be understood by reference to Figs. 8 and 9, where it will be seen that when the plate is down and the needle retracted the braid is free to be fed by the rollers *m*; but when the plate rises it bends the braid around the angular portion of the upper feed-roll, and forms a crimp for the passage of the needle.

We claim as our invention—

1. The within-described feed-rolls for sewing-machines, the said rolls being circular with angular extensions, as specified.
2. The combination of the feed-rolls of a sewing-machine with the forked crimping-plate *n* and mechanism, substantially as described, for reciprocating said crimping-plate.
3. The combination of the lower feed-roll with the plate *l*, carried by and moving with the bearing of said lower feed-roll, as and for the purpose set forth.
4. The guide *T* and adjustable gage-plate *t*, in combination with a spring and screw or pin for keeping the two in contact, substantially as specified.

In testimony whereof we have signed our names to this specification in the presence of two subscribing witnesses.

FREDERICK BLACKBURN.
VALENTINE MOESLEIN.

Witnesses:

HARRY A. CRAWFORD,
HARRY SMITH.