

W. M. CARRIKER.
Corn-Planter.

No. 200,027.

Patented Feb. 5, 1878.

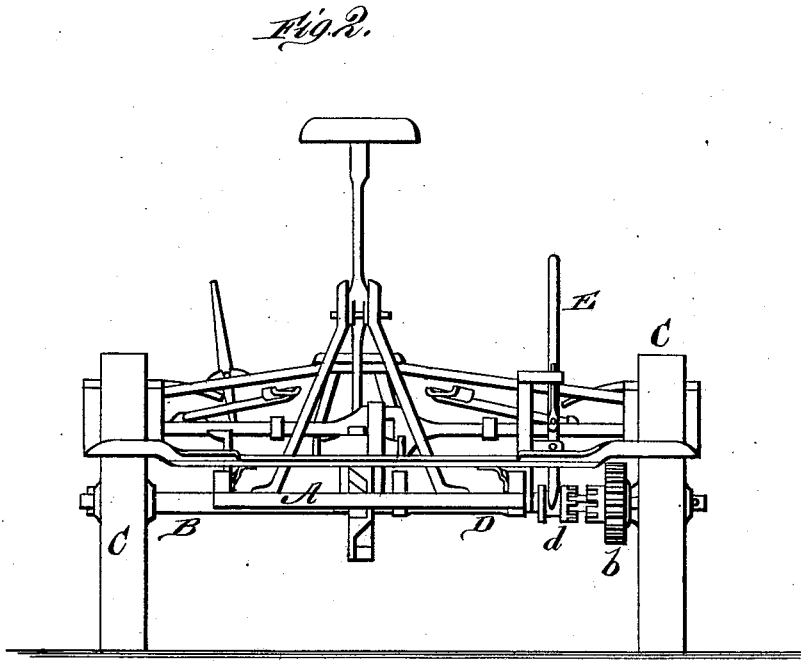
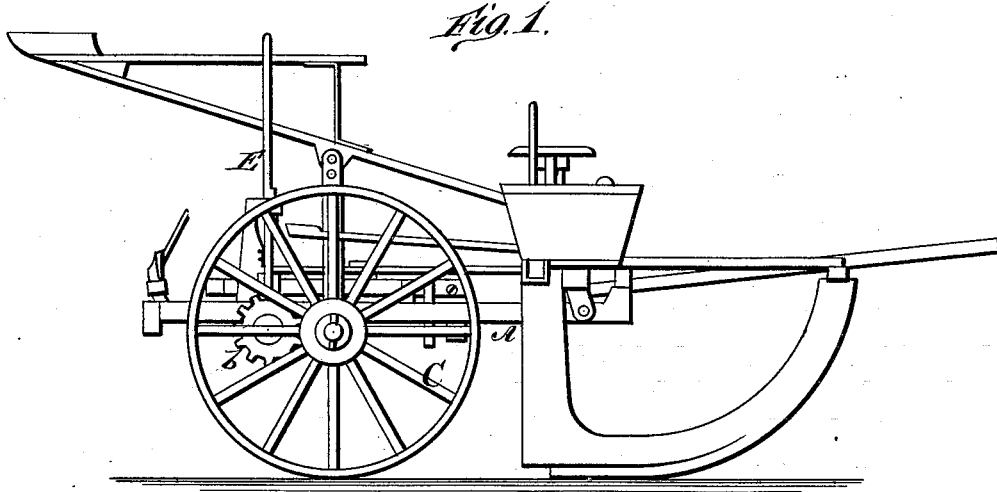

WITNESSES
Robert Everett
James J. Sheehy

INVENTOR.
Wm. M. Carriker.
Glenn & Smith Co.
ATTORNEYS.

W. M. CARRIKER.
Corn-Planter.

No. 200,027.

Patented Feb. 5, 1878.

Fig. 3.

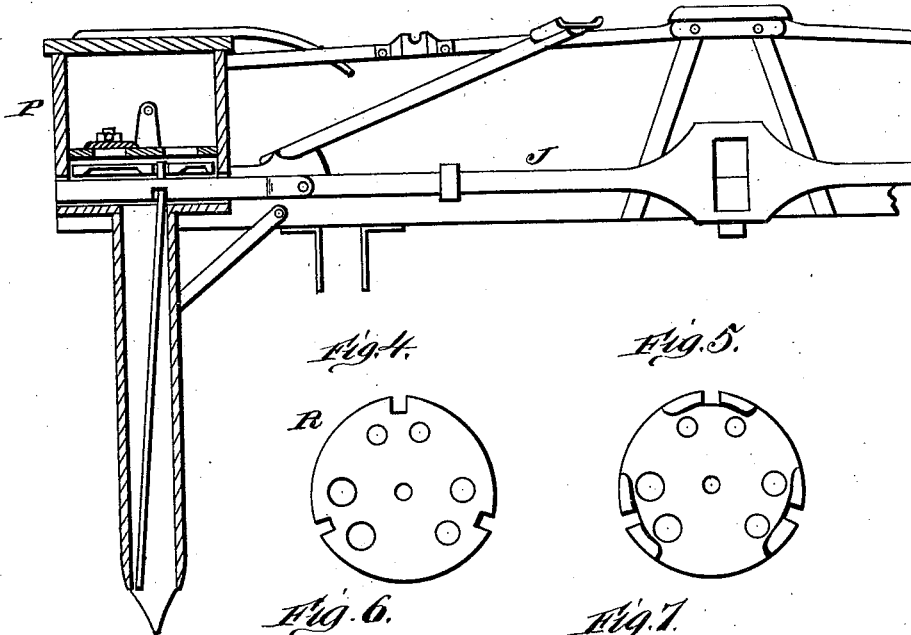

Fig. 4.

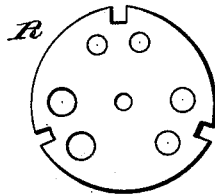

Fig. 5.

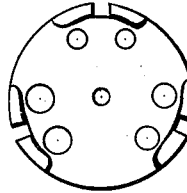

Fig. 6.

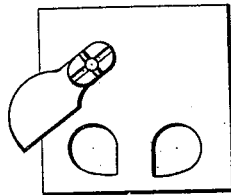

Fig. 7.

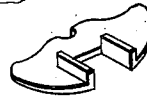
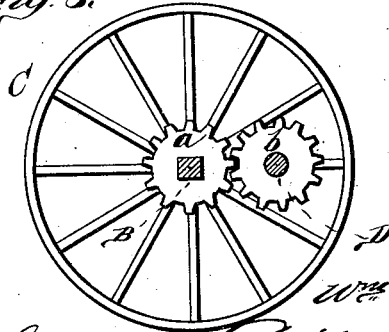

Fig. 8.



WITNESSES

Robert Smith
James J. Sheehy

INVENTOR.

Wm. M. Carriker

Gilmore & Smith Co.

ATTORNEYS.

W. M. CARRIKER.
Corn-Planter.

No. 200,027.

Patented Feb. 5, 1878.

Fig. 9.

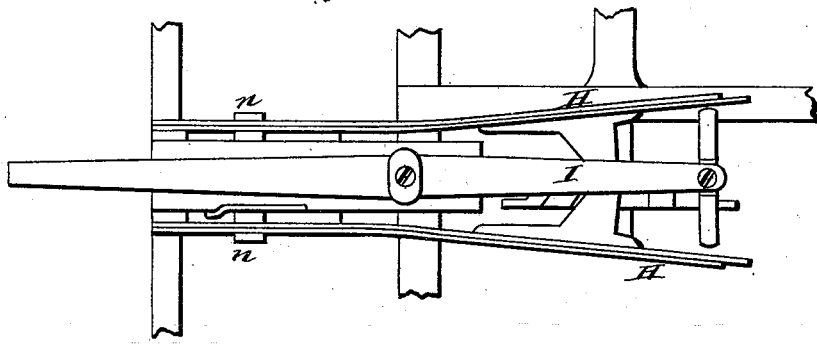

Fig. 10.

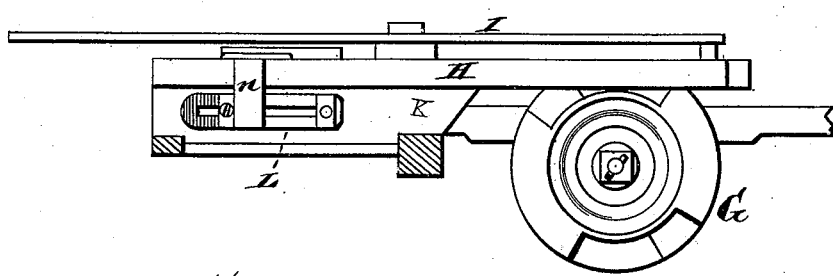

Fig. 11.

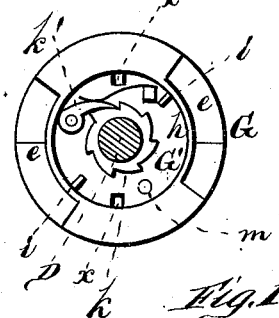

Fig. 12.

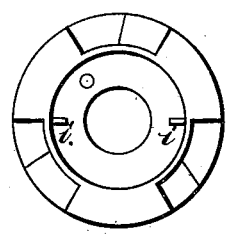

Fig. 13.



Fig. 14.

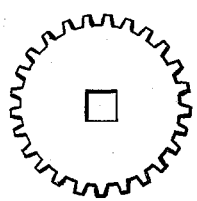
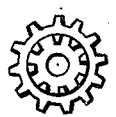

Fig. 15.



WITNESSES

Robert Emmett
James J. Sheehy

INVENTOR.

Wm. M. Carriker.

Fig. 16.

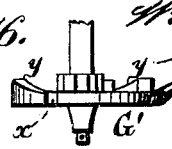

Gilmore Smith

ATTORNEYS.

UNITED STATES PATENT OFFICE.

WILLIAM M. CARRIKER, OF IRVING, ILLINOIS.

IMPROVEMENT IN CORN-PLANTERS.

Specification forming part of Letters Patent No. **200,027**, dated February 5, 1878; application filed December 1, 1877.

To all whom it may concern:

Be it known that I, WILLIAM M. CARRIKER, of Irving, in the county of Montgomery and State of Illinois, have invented a new and valuable Improvement in Corn-Planters; and I do hereby declare that the following is a full, clear, and exact description of the construction and operation of the same, reference being had to the annexed drawings, making a part of this specification, and to the letters and figures of reference marked thereon.

Figure 1 of the drawings is a side view of my corn-planter. Fig. 2 is a rear view; and Figs. 3, 4, 5, 6, 7, 8, 9, 10, 11, 12, 13, 14, 15, and 16 are details of the same.

The nature of my invention consists in certain improvements upon the corn-planter for which Letters Patent No. 175,925 were granted to me April 11, 1876, as will be hereinafter more fully set forth, and pointed out in the claims.

The annexed drawings, to which reference is made, fully illustrate my present invention.

The general shape and the construction of the main portion of the corn-planter are substantially the same as described in my patent above referred to, and hence need no description here.

A represents the main frame secured to the axle B, on the ends of which are placed the driving-wheels C C. One of these wheels is, on the inner end of its hub, provided with a pinion, *a*, which meshes with a cog-wheel, *b*, upon a counter-shaft, D. This cog-wheel *b* is loose on the shaft, and connected therewith or disconnected therefrom, as required, by means of a clutch, *d*, operated by a lever, E, as shown. The gears *a* and *b* may be removed and others of different diameter substituted, so as to regulate the speed of the counter-shaft D, and thereby gauge the distance between the hills.

On the inner end of the shaft D is placed a tappet-wheel having any desired number of tappets. This tappet-wheel is made in two parts, the outer part G being provided with the tappets *e e*, and having on one side a concentric recess, *h*, with two pins, *i i*, projecting inward from the walls of said recess at oppo-

site sides. The inner portion G' of the tappet-wheel consists simply of a circular disk provided with a pawl, *k'*, taking into a ratchet-wheel, *k*, secured on the shaft D. The disk G' is of such size as to fit in the recess *h* of the wheel G, and has slots *x x* in its edge for the passage of pins *i i*.

On the inner face of the disk G' are formed inclines *y y*, so that after the pins *i* have passed through the slots *x*, by turning the wheel G, the pins *i* will ride up said inclines *y*, and thus draw the two parts firmly together. They are then locked together by means of a pin or key, *m*, passed through them.

By removing the key *m* the wheel G can be easily detached and another wheel with different number of tappets substituted in its place.

It is the intention, in a full-sized machine, to have at least two sets of gear-wheels, *a b*, and wheels G, one set being used for dropping the corn in hills, and the other set for drilling, say, every ten inches, and only one grain at a time.

The tappets *e* of the wheel G operate upon spring-fingers H H, having beveled teeth on them, and between these spring-fingers is located the T-head of a laterally-vibrating lever, I, the front end of which is jointed to the slide J, whereby, as the machine is in motion, said slide obtains the required reciprocating movement.

The spring-fingers H H are adjusted to regulate their tension by means of a slide, L, passing through the bar K, to which said spring-fingers are connected. This slide has two arms, *n n*, passing upward against the sides of the fingers, and by moving the slide back and forth the tension or strength of said spring-fingers is easily regulated.

R R are the dropping-wheels working in the hoppers P P, and two or more sets of these wheels are to be provided for each machine, so as to use one set for drilling and one for hilling, and still another for smaller seed when required.

What I claim as new, and desire to secure by Letters Patent, is—

1. The combination of the driving-wheel C, counter-shaft D, gears *a b*, clutch *d*, with lever E, tappet-wheel G G', and spring-fingers H H, substantially as and for the purposes set forth.

2. The slide L, with arms *n*, in combination with the bar K and spring-fingers H H, for the purposes set forth.

In testimony that I claim the above I have hereunto subscribed my name in the presence of two witnesses.

WILLIAM M. CARRIKER.

Witnesses:

EDMUND CARRIKER,

CHAS. A. RAMSEY.