

J. EVANS.
Steam-Pump.

No. 200,035.

Patented Feb. 5, 1878.

FIG. 1.

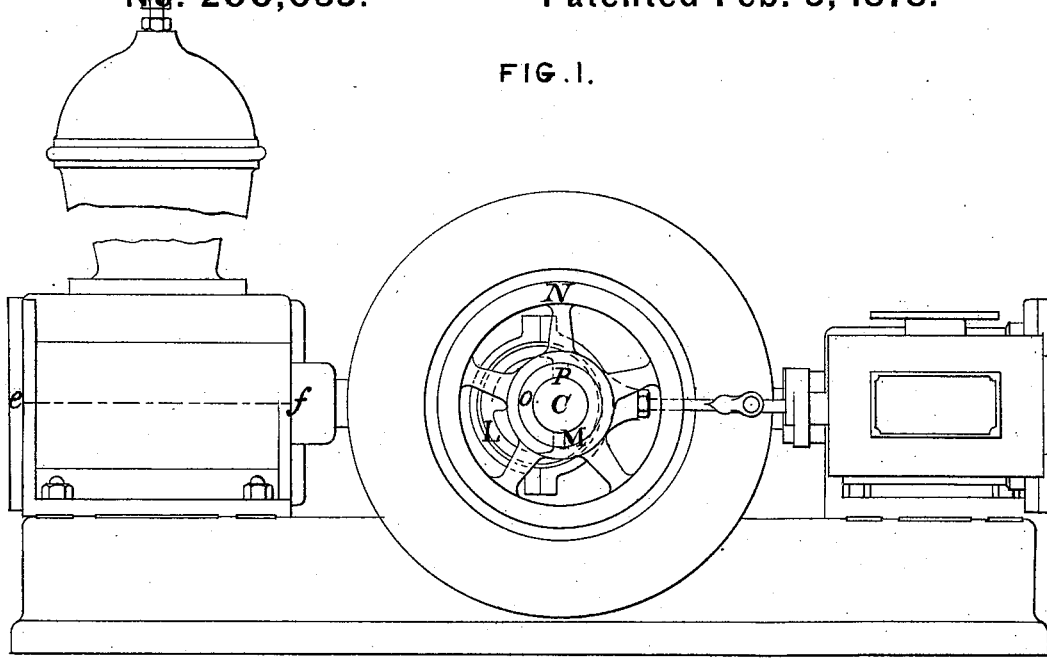
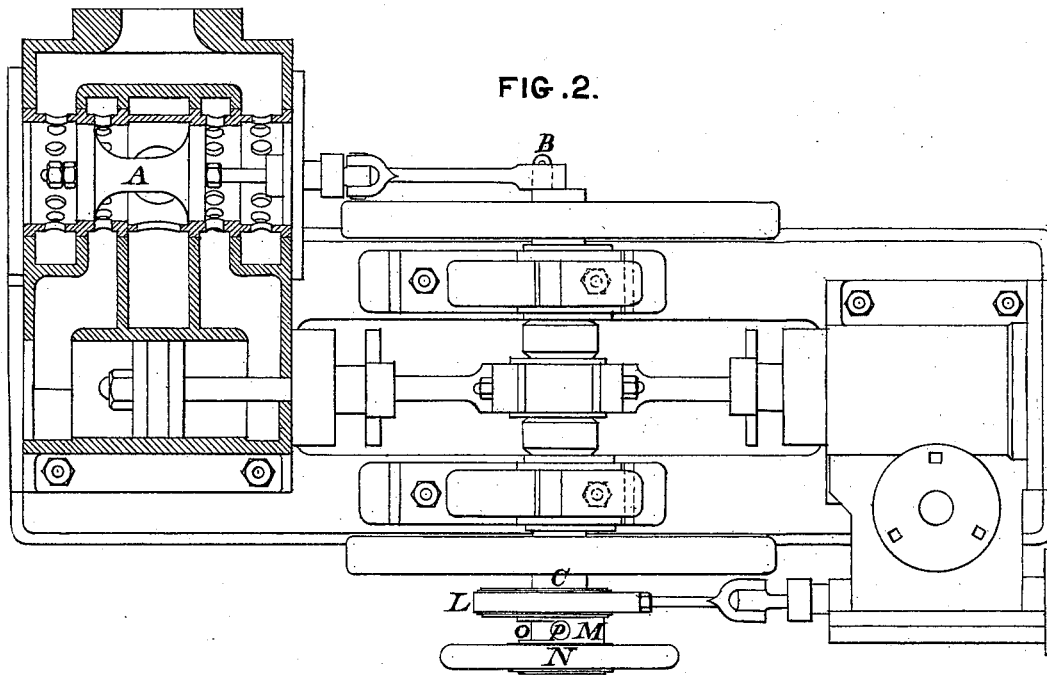

FIG. 2.



WITNESSES

C. H. Trill
F. W. Farleigh

INVENTOR

Joseph Evans
Colborne, Brookes
Attorney

J. EVANS.
Steam-Pump.

No. 200,035.

Patented Feb. 5, 1878.

FIG. 3.

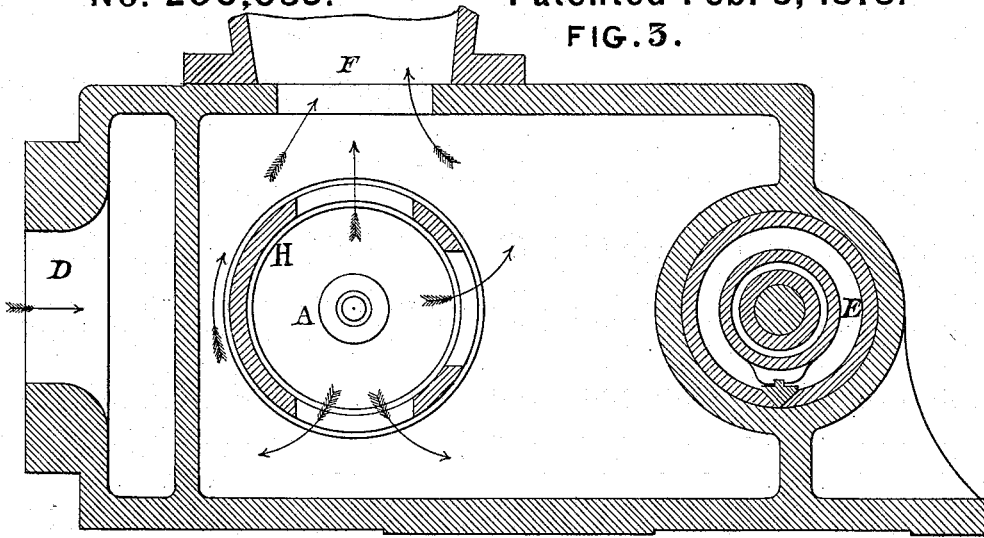
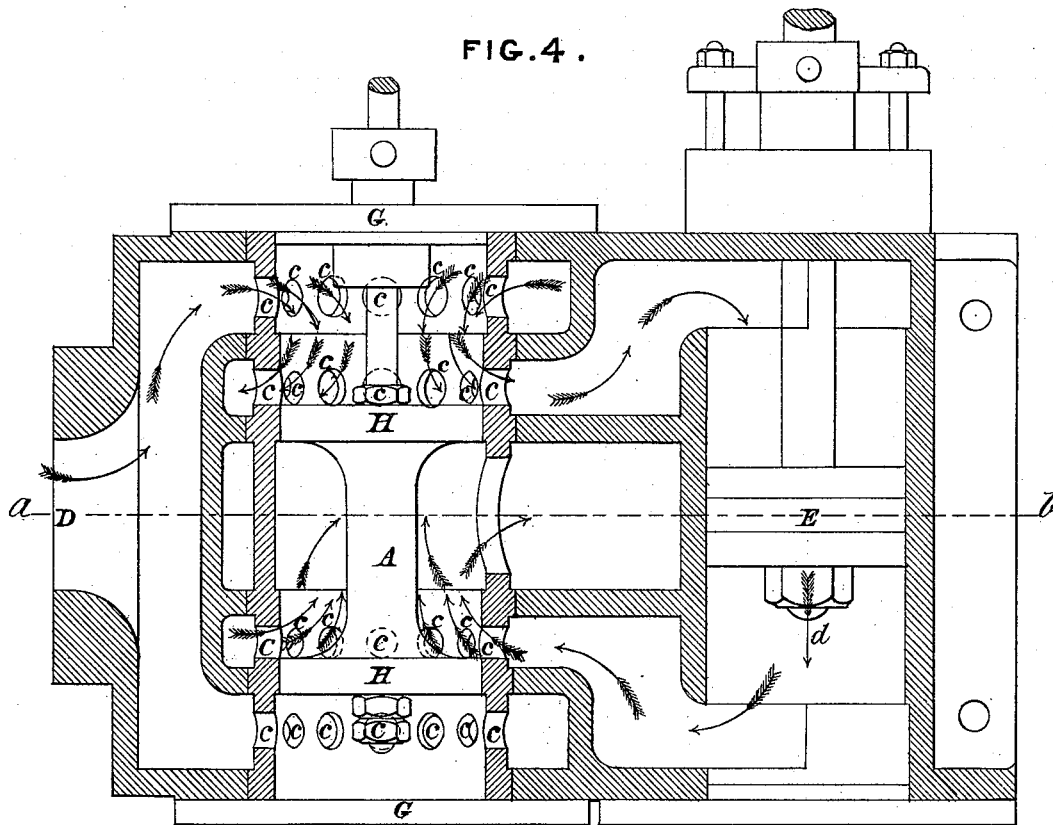

FIG. 4.



WITNESSES

C. P. Britton
J. W. Starleigh

By

INVENTOR
Joseph Evans
Colborn Brookes
Attorney

UNITED STATES PATENT OFFICE.

JOSEPH EVANS, OF WOLVERHAMPTON, GREAT BRITAIN.

IMPROVEMENT IN STEAM-PUMPS.

Specification forming part of Letters Patent No. **200,035**, dated February 5, 1878; application filed June 14, 1876.

To all whom it may concern:

Be it known that I, JOSEPH EVANS, of Wolverhampton, in the county of Stafford, in the Kingdom of Great Britain, have invented certain new and useful Improvements in Pumps; and I do hereby declare that the following is a full, clear, and exact description thereof, which will enable others skilled in the art to which it appertains to make and use the same, reference being had to the accompanying drawings, and to the letters of reference marked thereon, which form a part of this specification.

This invention refers to a method of reversing the action of pumps provided with either piston-valves, as described, or with slide-valves actuated by means of an eccentric, disk, crank, or equivalent, on the revolving shaft, so that the suction-pipe becomes the delivery-pipe and the delivery-pipe becomes the suction-pipe; and consists in reversing the direction of the rotation of the revolving shaft in the following manner: In the case of pumps worked by means of a steam-cylinder I actuate the steam-valve by means of a separate eccentric, disk, crank, or equivalent, working loose on the revolving shaft, and regulated by a fast stud or block in any manner now in use for reversing the action of steam-engines, or by any suitable reversing arrangement now in use for reversing the action of steam-engines, as will be readily understood. In the case of pumps worked by hand or other animal power, the reverse action of the pump is effected by simply reversing the rotary motion.

For reversible pumps the retention valve or valves, if used, must, of course, be alternately arranged to suit the direction of the water-flow.

Having thus stated the nature of the said invention, I now proceed more particularly to describe the manner of performing the same with reference to the accompanying drawings.

The same letters occurring on different views indicate the same parts.

My invention is illustrated by part of Figure 2, which is a plan of Fig. 1, partly in section, namely, on the line *ef* of Fig. 1.

A is the piston-valve. B is a stud or crank-pin turned out of the revolving shaft C, and having its center the proper distance from the

shaft-center to give the required stroke to the valve. The stud or crank-pin B is set in such position relatively to the crank or other part giving motion to the pump that the valve shall open and close the ports at the proper time. An enlarged view of the valve A, showing also the ports and pump, is illustrated by Figs. 3 and 4.

Fig. 3 is a section on line *ab* of Fig. 4. Fig. 4 is a sectional plan taken on line *ef* of Fig. 1, the same as is shown in Fig. 2, but to an enlarged scale.

Referring to Figs. 3 and 4, A is the piston-valve. D is the suction opening into the valve-box. The pump-piston E is represented as moving in the direction of the arrow *d*, and the suction and delivery will be readily understood by means of the arrows. F is the delivery-opening from the valve-box.

It will be seen from the drawing that the cylinder inside which the valve works is itself a separate piece from the main casting of the pump and box, and is retained in its place by means of the lids G G.

The small openings *c c*, &c., are used for the working part of the cylinder in preference to oblong openings, so as to retain a proper facing all around, and are used for the ends beyond the working part, so as to retain an equal distribution of metal round the cylinder.

The collars or faces H H of the valve A are the same distance from the outer edge of one to the outer edge of the other as the outer edge of one port is from the outer edge of the other port, but slightly—say about one-sixteenth of an inch—farther apart from the inner edge of one collar to the inner edge of the other collar than the inner edge of one port to the inner edge of the other port, so as to prevent the liquid in the pump from being trapped as the valve-collar is traveling over the ports.

The steam-valve is worked by means of an eccentric, L, fixed on a boss, M, to which is also fixed a hand-wheel, N. The said boss M is bored to turn on the shaft C, and has a slotted part, O, cut out of its circumference. A stud, P, fixed in the shaft C, acts as a stop for the boss M at each end of the slotted part O—that is, for forward and backward stroke of

the engine and pump. The stud P acts also as a guide to the boss M to keep it in position side-wise.

In starting the engine the forward or backward stroke will be given accordingly as the hand-wheel N is turned backward or forward.

It will readily be seen that from the arrangement of the pump, actuated as shown, on reversing the revolving shaft C, what was before the suction-opening to the pump-valve will become the delivery-opening, and what was before the delivery-opening will become the suction-opening. Hence, in the case of pumps with the valves worked as shown in Fig. 2, which are actuated by hand or other animal power, to reverse the action of the pump, it is necessary only to reverse the direction in which the power is exerted.

By reversing the pump the delivery-pipes, pump-barrel, and passages may be emptied of water to avoid the action of frost, or may be emptied of thick liquids—such, for instance, as tar—to prevent congealing. This arrangement is also useful in starting the pumping-engine.

Having now particularly described and as-

certained the nature of my said invention, and in what manner the same is to be performed, I wish to state distinctly that I do not claim any of the parts I have described if taken by themselves, as many of them are old, and I am not sufficiently assured of the novelty of any of them to claim them as my invention; but

I claim as my invention—

1. In combination with the reversing-eccentric to actuate the steam-valve of a steam-pumping engine, an eccentric disk or crank for actuating the pump-valve, substantially as shown and described.

2. The reversing-eccentric to actuate the steam-valve of a steam-pumping engine and an eccentric disk or crank for actuating the pump-valve, in combination with the steam and pump valve, substantially as described.

In testimony that I claim the foregoing as my own I affix my signature in presence of two witnesses.

JOSH. EVANS.

Witnesses:

STEPHEN WATKINS,

JAMES A. WYNN.