

W. R. FINCH.
Breech-Loading Fire-Arms.

No. 200,042.

Patented Feb. 5, 1878.

Fig. 1.

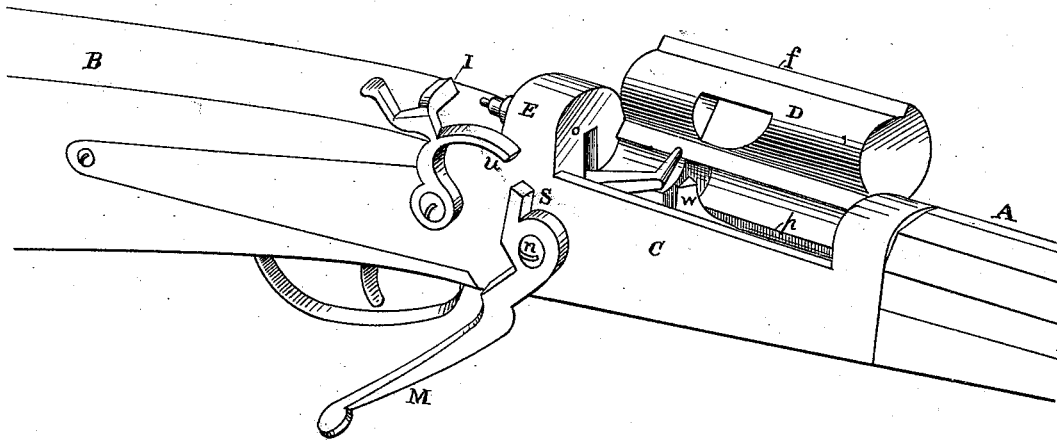

Fig. 2.

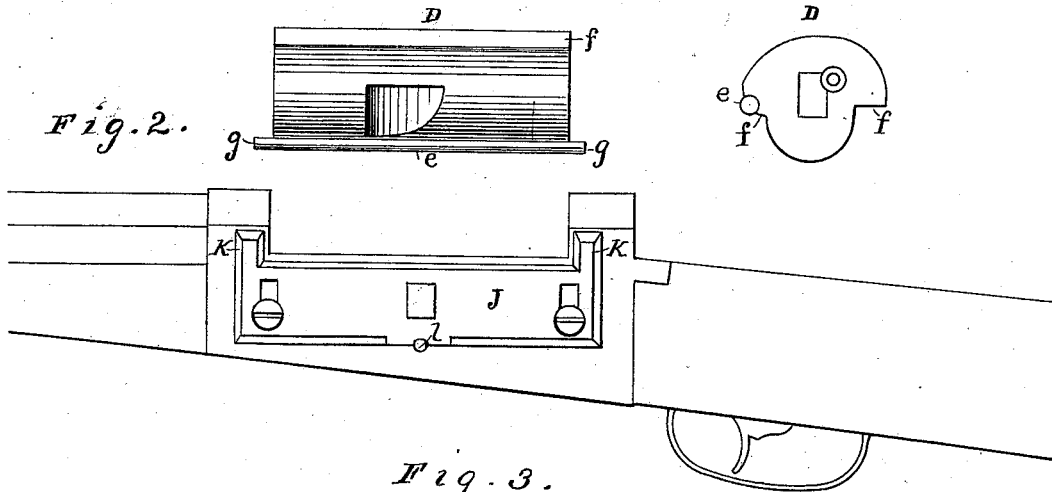
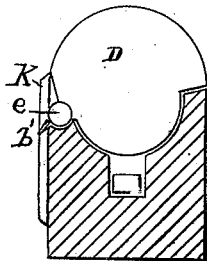

Fig. 3.



Witnesses
Geo. L. Boone
Geo. H. Strong

Inventor
William R. Finch
 by *Dewey & Co*
 Attys

W. R. FINCH.
Breech-Loading Fire-Arms.

No. 200,042.

Patented Feb. 5, 1878.

Fig. 4.

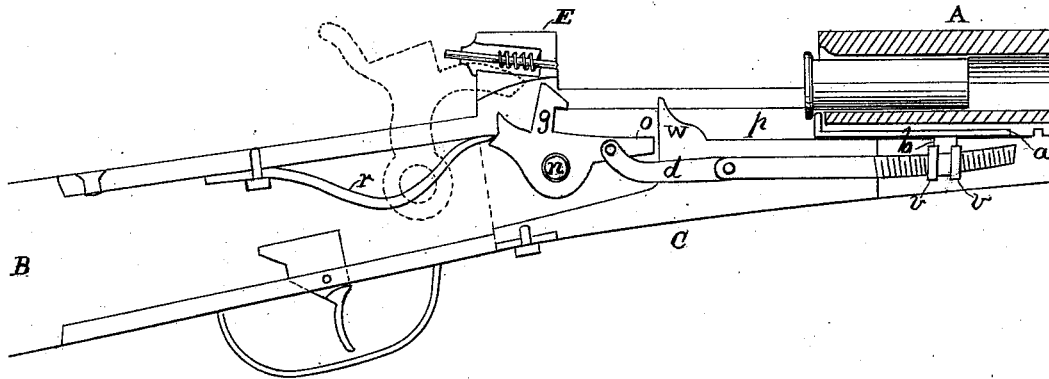

Fig. 5.

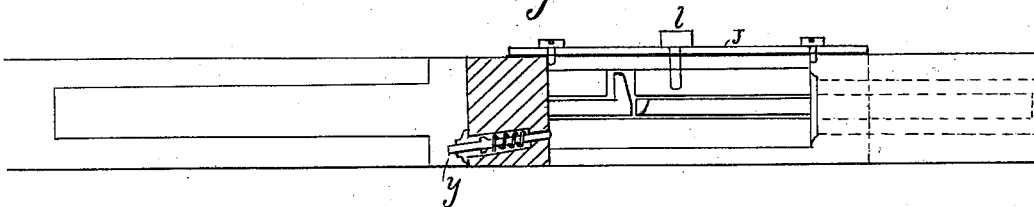
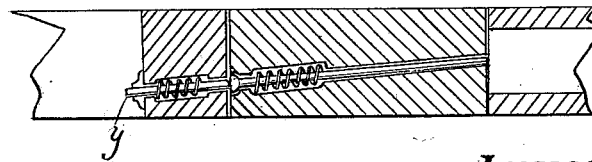

Fig. 6.



Witnesses

Geo. L. Poome
Geo. H. Strong

Inventor

William R. Finch
by *Dewey & Altys*

UNITED STATES PATENT OFFICE.

WILLIAM R. FINCH, OF EUREKA, CALIFORNIA.

IMPROVEMENT IN BREECH-LOADING FIRE-ARMS.

Specification forming part of Letters Patent No. **200,042**, dated February 5, 1878; application filed December 5, 1877.

To all whom it may concern:

Be it known that I, WILLIAM R. FINCH, of Eureka, in the county of Humboldt, State of California, have invented Improvements in Breech-Loading Fire-Arms; and I do hereby declare the following description and accompanying drawings are sufficient to enable any person skilled in the art or science to which it most nearly appertains to make and use my said invention without further invention or experiment.

My invention relates to that class of breech-loading fire-arms in which the breech-block is hinged to one side of the barrel, so as to open upward and laterally; and it consists in a novel method of constructing, applying, and mounting the breech-block, so that it can be easily detached from the barrel when desired, so as to disable the gun.

It also consists in certain improvements in the application of the lever which releases and opens the breech-block and operates the shell-extractor.

Referring to the accompanying drawings, Figure 1 is a perspective view with the breech-block opened out. Fig. 2 is a side elevation with the breech-block removed. Fig. 3 is a transverse section. Fig. 4 is a longitudinal section. Figs. 5 and 6 are sectional views, showing the firing-pin.

Let A represent the barrel, B the stock, and C the breech, of the gun. The recess in which the breech-block D fits is made by cutting out a portion at the rear end of the barrel, so as to leave a solid block of metal, E, behind the breech-block. This recess is long enough to permit the introduction of the cartridge when the breech-block is raised.

The breech-block is a solid block of metal, circular on top to correspond with the top of the barrel, and with an offset, *f*, on each side, which rests upon the sides of the recess or concavity in which the block fits. Its under half is also circular, but on a smaller radius, so as to fit in the recess.

This block I hinge to the left-hand side of the barrel as follows: Along the left-hand offsets or shoulders of the block I make a circular bead or rib, *e*, and extend it beyond the breech-block at each end, so as to form journals *g g*. The upward-projecting edges on the

left-hand side of the recess are cut out, forming seats or bearings *b'*, within which the journals *g g* of the bead E fit, said journals being held therein by the arms K of the plate J when pushed up and fastened, as clearly shown in Fig. 3.

The plate is slotted near each end, and a screw passes through each slot, so that the plate can be moved up or down the length of the slots. When up, the arms K cover the open seats and confine the journals of the breech-block; but when down the seats are uncovered and the journals will drop out, thus detaching the breech-block. A spring push-pin, *l*, serves to latch the plate J in place when it is raised.

The breech-block opens and closes on the journals *g g*, so that it opens upward and laterally, as shown.

The lever M, by means of which the breech-block is thrown open, is attached to a short shaft, *n*, which passes into the barrel below the rear end of the breech-block. This lever extends along under the hammer, and to a distance in rear of it, where it will be most convenient to the thumb of the person who holds the gun.

A longitudinal channel, *p*, is made in the bottom of the chamber or recess in which the breech-block fits, and in this channel the devices which operate the breech-block and shell-extractor are placed.

The inner end of the shaft *n* is firmly attached to a two-armed lever, one arm of which, marked *o*, lies in the channel *p* below the breech-block, while the other, *g*, stands upright, and fits in a recess in the block in rear of the breech-block. This upright arm *g* has a latch-head on its upper end, and a flat spring, *r*, is arranged to press it forward, as shown. The breech-block has a recess in its rear end, into which the latch-head of the arm *g* is forced by the spring, when the block is closed down. The arm *o* of the lever passes forward a short distance under the breech-block in the channel *p*, so that when the lever M is thrown down the latch *g* is thrown backward out of the recess in the breech-block, so as to free the block, just as the lever *o* moves upward against it to throw it open.

The lever M has a projection or arm, S, ex-

tending upward from near its pivoted end, and the hammer I has a nose or projection, *u*, extending forward from it alongside the barrel, so that, as the lever is thrown down, the arm S will push backward upon the nose of the hammer and set it at a half-cock, thus relieving the pressure of the hammer on the firing-pin, so that it can clear itself from the breech-block.

The shell-extractor consists of the bar *a*, which moves in an extension of the channel *p* under the barrel, as shown at Fig. 4. This bar has a lug, *b*, on its under side, and the lug is connected with the arm *o* by a hinged rod, *z*, so that the same movement of the lever M which unlatches the breech-block and forces it open operates the retractor. The end of the rod *d* is formed into a screw, and is attached to the lug *b* of the extractor-bar by means of two set-nuts, *v v*, between which the lug passes. By setting these nuts toward or from the end of the rod, the movement of the extractor can be adjusted to any time or distance of movement desired.

W is an inclined block, which is secured in the bottom of the cavity in which the breech-block fits, and which serves to throw the ejected cartridge out of the recess.

To fire the cartridge I use a firing-pin, which is made in two separate pins or sections. One of these pins extends longitudinally through the metal block in line with the center of the cartridge, while the other, *y*, passes through the metal block E in rear of the breech-block. These pins are so adjusted that when the breech-block is closed down they will be in line with each other, so that a percussion on the projecting end of the pin *y* will force it against the end of the pin *x*, and thus fire the cartridge.

By making an indentation in the rear end of the breech-block, into which the end of the firing-pin *y* will enter when the breech-block

is half open, I can throw the two firing-pins out of line with each other, and thus render the gun perfectly safe even when it is loaded.

The operation of loading is then accomplished as follows: The person who holds the gun presses the lever M downward and forward with the thumb of his right hand. This sets the hammer at half-cock, unlatches the breech-block, forces it open, and discharges the spent cartridge-shell. He then instantly draws the lever back with his hand. This restores the latch-lifting lever and retractor to their proper positions. He then inserts the fresh cartridge and closes the breech-block, when the gun is again ready to fire. If he should at any time desire to disable the gun, he can do so by detaching the breech-block and placing it out of reach.

This arrangement is very strong, simple, and easily operated. The gun has no projecting or cumbrous parts, and cannot therefore become fouled by ordinary usage.

Having thus described my invention, what I claim, and desire to secure by Letters Patent, is—

1. The breech-block D, with its journals *g g*, arranged to be journaled in the open seats or bearings *b'*, in combination with the sliding plate J, with its covering-arms K, and the spring press-pin *l*, or equivalent device, substantially as and for the purpose described.

2. The lever M, connected by the shaft *n* with the latch-lever *g* and lifting-lever O, said lifting-lever being connected with the shell-retractor *a* by the hinged bar *d* and set-nuts *v v*, substantially as and for the purpose described.

In witness whereof I have hereunto set my hand and seal.

WILLIAM R. FINCH. [L. S.]

Witnesses:

FRANK A. BROOKS,
WM. H. THOMPSON.