

J. J. LOVE.
 Apparatus for Boring or Broaching.

No. 200,071.

Patented Feb. 5, 1878.

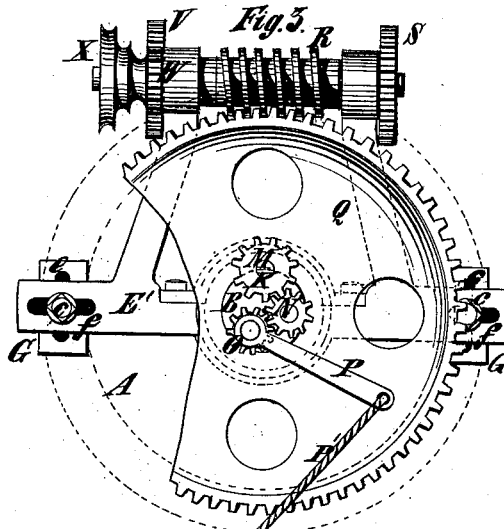
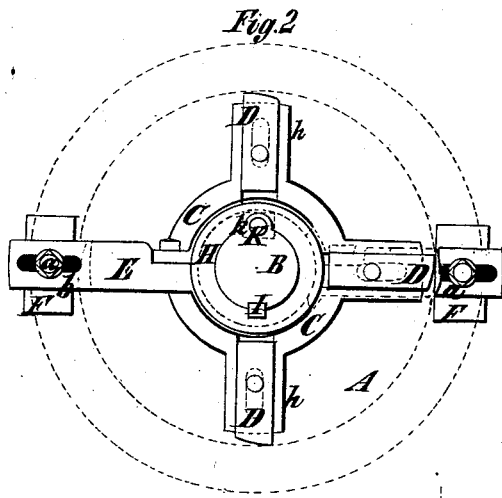
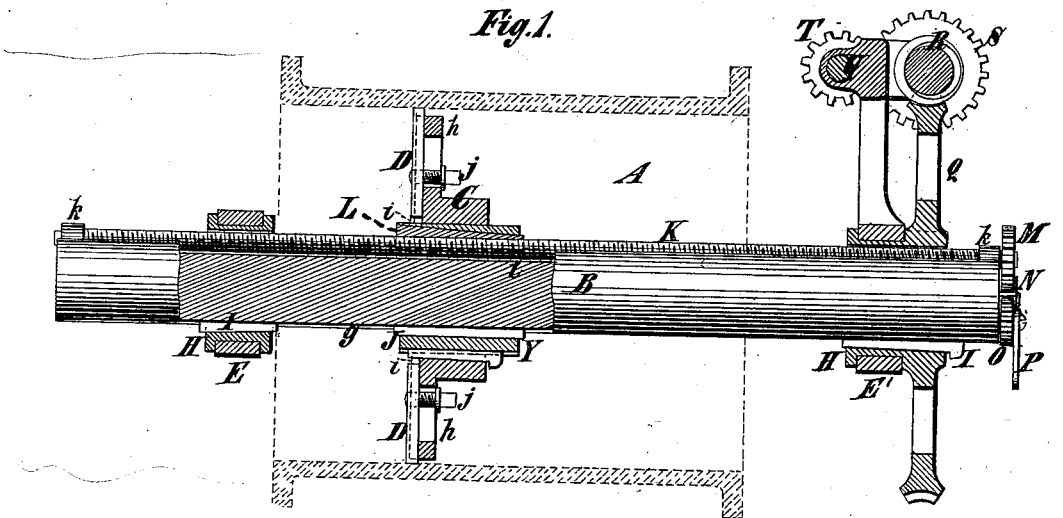

Witnesses:
 Chandler Hall
 Matthew J. McKee

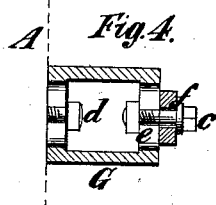

Inventor
 John J. Love,
 by his Atty,
 Edwin H. Brown.

UNITED STATES PATENT OFFICE.

JOHN J. LOVE, OF NEW YORK, N. Y.

IMPROVEMENT IN APPARATUS FOR BORING OR BROACHING.

Specification forming part of Letters Patent No. **200,071**, dated February 5, 1878; application filed August 13, 1877.

To all whom it may concern:

Be it known that I, JOHN J. LOVE, of the city, county, and State of New York, have invented certain new and useful Improvements in Apparatus for Boring or Broaching, of which the following is a description:

My improvements relate particularly to machinery employed in broaching, dressing, or boring cylinders for steam-engines, pumps, &c. In embodying these improvements in machinery, for the purpose first mentioned, I support the shaft carrying the cutters in bearings, having a slotted connection with head-pieces fastened to the cylinder to be operated upon, whereby said shaft may be readily attached to, adjusted in, and detached from the cylinder. I support the shaft in a bearing receiving an adjustable journal provided with flanges overlapping said bearing, whereby the shaft may be supported close to the end of the cylinder, and will be precluded from shifting longitudinally.

I operate the cutter-head with its cutters longitudinally along the cylinder by a screw shaft or worm operating upon a nut made externally taper, so as to wedge in the cutter-head, or a sleeve on which it is mounted, and compensate for wear or differences in size, and impart a steady motion to the cutters. I impart motion to the cutter-shaft through a worm and worm-wheel, as usual; but I drive the worm by a combination of gearing producing great power. I drive the screw-shaft for moving the cutters lengthwise of the cylinder by a gear-wheel, which derives motion by revolving around a gear-wheel which has but a limited movement as the said shaft rotates on its axis, and I insert the cutters in mortised arms provided with longitudinal slots, and secure them with bolts.

In the accompanying drawings, Figure 1 is a side view of an apparatus embodying my invention, certain parts being shown in section, and a central longitudinal section of a cylinder being represented in dotted outline. Fig. 2 is a view of the end farthest from the driving-gear, including an end view of the cylinder in dotted outline. Fig. 3 is an end view thereof where the driving mechanism is located, including an end view of the cylinder in dotted outline; and Fig. 4 is a detail side view of

one of the connections between the cylinder, one end of which is here represented in dotted outline, and the bearing for the shaft attached to that end of the cylinder.

Similar letters of reference designate corresponding parts in all the figures.

A designates a cylinder, which I have shown in dotted outline because, of itself, it forms no part of my invention. B designates a rotary shaft, which is shown as supported from the said cylinder, and on which is mounted a movable cutter-head, C, carrying cutters D for broaching or dressing the cylinder, or for "boring" it, as this work is more commonly termed. This shaft is shown as supported in bearings E E', which are shown as sustained by the cylinder A. The bearing E is shown as fastened directly to the adjacent flange of the cylinder A by bolts or screws *a* passing through slots *b*, blocks F being interposed between this bearing and said flange to throw it far enough outside of the cylinder to accommodate the hub of the movable cutter-head C, and admit of the cutters operating upon the cylinder to its extreme end. The bearing E', however, is shown as fastened by bolts *c* to head-pieces G, secured by bolts *d* to the other flange of the cylinder A, so as to allow the hub of the movable cutter-head C to extend so far outside of the cylinder that the cutters D may operate on the cylinder at the adjacent end.

Preferably the bolts *c*, securing this bearing E' to the head-pieces G, pass through slots *e* in the head-pieces, and through slots *f* in the bearings extending perpendicularly to the former, in order to provide for the adjustment of the shaft B vertically or horizontally, or both vertically and horizontally, to cause the cutters D to operate properly within the cylinder A. The slots *b* in the bearings E also afford provision for this adjustment. It will be observed that the shaft is not provided with fixed journals fitting in these bearings E E'; but it is furnished with journals consisting of sleeves H, which are provided with flanges overlapping the bearings, and which are secured to the shaft B, so as to rotate with it, by splines I, tapering like keys, and fitting in a groove, *g*, in said shaft, and therefore that, no matter how long or short the cylinder to be broached, dressed, or bored may be, the

bearings and journals may be adjusted on the shaft to support it close to the ends of the cylinder. This combination of journals and bearings is very advantageous, for it enables the shaft to be supported with the greatest steadiness, whereas the cutter-carrying shaft of ordinary apparatus for broaching, finishing, or boring cylinders having fixed journals has, in broaching, dressing, or boring a short cylinder, to be supported at such a great distance from one end thereof as to be very unsteady, which is, of course, exceedingly detrimental to the work performed in the cylinder.

The movable cutter-head C is mounted on a sleeve, Y, furnished with a spline, J, fitting in the groove *g* in the shaft B, and securing it to said shaft, so that it rotates therewith, and, withal, providing for its movement lengthwise of the said shaft, so as to operate throughout the length of the cylinder to be broached, dressed, or bored. This cutter-head C has radial arms *h*, provided on one side with grooves *i*, in which are fitted the cutters D, bolts or screws J, passing transversely through them and through longitudinal slots in the said arms *h*, being employed to clamp and hold them in place in any suitable position.

The means for moving the cutter-head C, with its cutters D, longitudinally along the shaft B during their rotary movement requires particular description.

K designates a screw-threaded shaft or worm, (shown as supported by bearings *k* in a groove, *l*), extending longitudinally along the said shaft B, and driven, preferably, by mechanism which I will describe hereinafter. L designates a nut arranged in the sleeve Y of the movable cutter-head C, which tapers externally from the end, like a key, whereby, as soon as longitudinal motion of the cutter-head, operating worm or screw serves to tighten this nut in the sleeve of the cutter-head, all play between it and the sleeve incident to wear or difference in sizes is compensated for, and the cutters steadied and moved longitudinally along the cylinder, so as to operate uniformly on the cylinder, and avoid all jumping or other jerky and irregular movements, which tend to impair the quality of work thereon.

Although the screw-shaft or worm K may be operated in different ways, I prefer to operate it by means which I will now describe.

M designates a gear-wheel, which is mounted on one end of the said screw-shaft or worm. (See particularly Fig. 3.) N designates a gear-wheel, which is supported on a stud extending from the shaft B, and engages with the gear-wheel M; and O designates a gear-wheel, also mounted on a stud extending from the shaft B, and which has attached to it a lever, P, fastened at the outer end by a cord or other device, so as to limit the motion of the wheel during the rotation of the shaft B. The wheel O being limited in its motion, the gear-wheels M N are carried around it. The gear-wheel N derives motion from the wheel O,

and transmits it to the gear-wheel M, and thence to the worm or screw K, moving the cutters through the cylinder with great uniformity.

It is obvious that if the gear-wheel N should be limited in its movements, instead of the gear-wheel O, the screw-shaft or worm may be made to operate cutters along the cylinder with a reverse longitudinal movement, but otherwise with the same advantages, and that in this way a change in the feed of the cutters may be easily effected without any reversal of the main driving mechanism. Turning, now, to this main driving mechanism, Q designates a worm-gear wheel mounted on the shaft B, so as to impart rotary motion thereto. R designates a screw or worm, shown as supported from the bearing E', and driving the worm-gear wheel Q. S designates a large gear-wheel arranged on said worm or screw R. T designates a pinion or small gear-wheel mounted on a shaft, U, driving the gear-wheel S, and the screw or worm R, carrying the latter. V designates a large gear-wheel on the opposite end of the shaft U, and W designates a pinion or small gear-wheel, fitting loosely on the screw-shaft R, driving the large gear-wheel V, and through its appurtenances the screw or worm R and shaft B, and deriving motion from the pulley X, driven by a belt or otherwise.

This combination of gears enables broaching, dressing, or boring apparatus with a small amount of power to be operated with sufficient energy for its work.

It will have been seen that by my invention I provide for adjusting the cutters of apparatus for broaching, dressing, or boring cylinders properly within the cylinders to be operated upon; that I provide for supporting the main shaft of said apparatus close to the cylinder to be operated on, no matter how long or short it may be; that I provide for easily adjusting the cutters; that I provide for moving the cutters longitudinally within the cylinder with a very uniform and regular motion; that I provide for operating the worm, imparting longitudinal motion to the cutter-head and cutters with great uniformity and regularity; and that I provide for effecting the operation of the cutters with sufficient energy with a small amount of power.

What I claim as my invention, and desire to secure by Letters Patent, is—

1. The combination, with the shaft B, frame E' for said shaft, and the driving mechanism therefor, of the rectangular head-pieces G, to be secured to the ends of a cylinder to be operated upon, said head-pieces being slotted in one direction, and said frame being slotted reversely at its points of connection with said head-pieces, substantially as described, whereby the said shaft and its driving mechanism may be readily attached to, adjusted in, and detached from a cylinder operated upon.

2. In an apparatus for broaching, dressing, or boring cylinders, the combination of a main

shaft provided with a longitudinal groove, an adjustable journal, a key for locking said journal in different positions, so as to turn with the said shaft, and flanges extending from the ends of said journal and overlapping the bearing in which it fits, substantially as specified, whereby longitudinal motion of the shaft is obviated.

3. The combination, with a screw-shaft or worm, of an apparatus for broaching, dressing, or boring cylinders, and the cutter-head or sleeve, which it moves longitudinally through a cylinder, subjected to the action of its cutters, of a nut tapering externally lengthwise,

substantially as specified, whereby all wear, or any difference in size between said nut and cutter-head or sleeve, is compensated for, and jumping and jerky movements incident to looseness are obviated.

4. The combination of the shaft B, bearings and journals E E' H, head-pieces G, cutter-head and cutters C h i D j, feeding worm or screw K, gears M N O, and driving mechanism Q R S T U V W X.

JOHN J. LOVE.

Witnesses:

EDWIN H. BROWN,
CHANDLER HALL.