

H. R. TOWNE & T. F. KEATING.  
Prison Lock.

No. 200,156.

Patented Feb. 12, 1878.

Fig. 1.

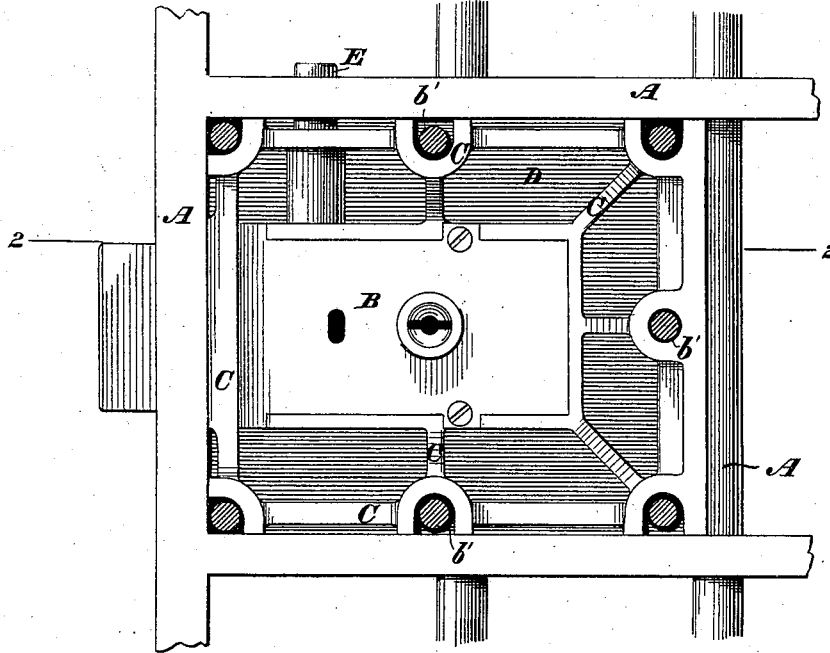
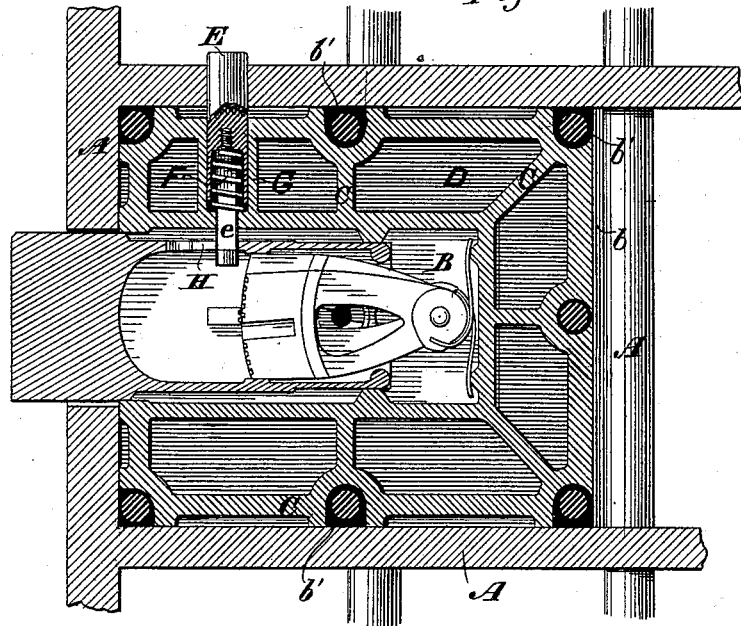

Fig. 2.



WITNESSES

Clarence Poole  
Wm. A. Skinkle

INVENTORS

Henry R. Towne  
Thomas F. Keating  
By his Attorneys  
Baldwin, Hopkins, & Peyton

H. R. TOWNE & T. F. KEATING.  
Prison Lock.

No. 200,156.

Patented Feb. 12, 1878.

Fig. 3.

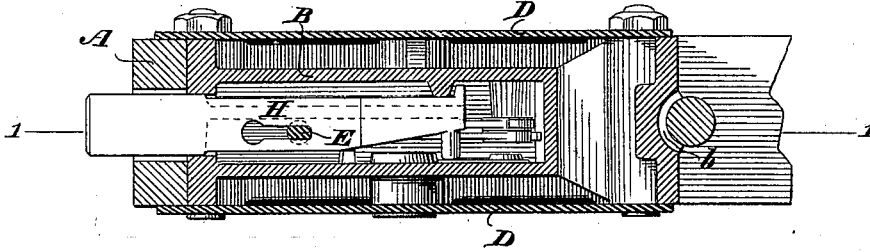

Fig. 4.

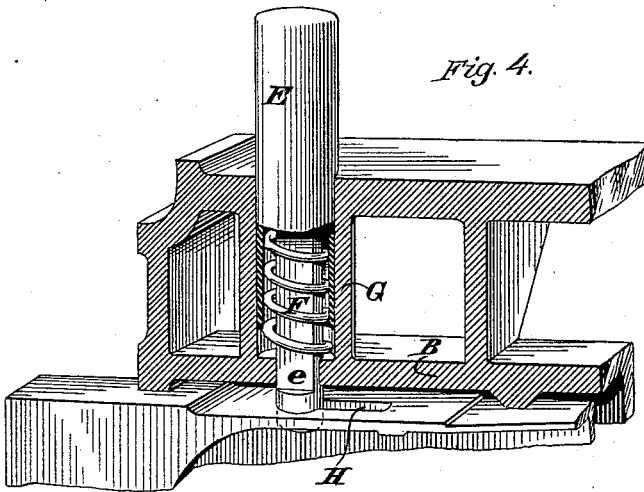
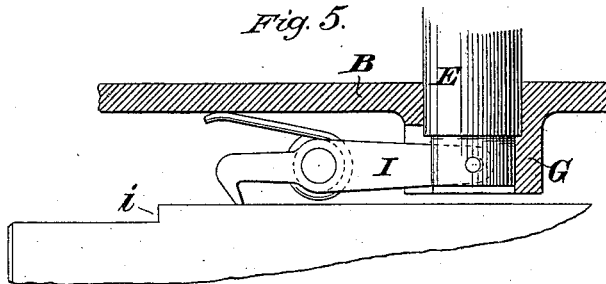

Fig. 5.



WITNESSES

Clarence Pool  
Wm A Skinkle

INVENTORS

Henry R Towne  
Thomas F Keating

By their Attorneys,  
Baldwin, Hopkins, & Peyton.

# UNITED STATES PATENT OFFICE.

HENRY R. TOWNE AND THOMAS F. KEATING, OF STAMFORD, CONNECTICUT,  
ASSIGNORS TO THE YALE LOCK MANUFACTURING COMPANY, OF SAME  
PLACE.

## IMPROVEMENT IN PRISON-LOCKS.

Specification forming part of Letters Patent No. **200,156**, dated February 12, 1878; application filed  
November 12, 1877.

*To all whom it may concern:*

Be it known that we, HENRY R. TOWNE and THOMAS F. KEATING, both of Stamford, in the county of Fairfield and State of Connecticut, have invented certain new and useful Improvements in Locks, of which the following is a specification:

Our improvements relate to locks for prison-doors, and their purpose is to increase the security afforded by such locks and to cheapen their production.

Prison-doors being commonly of iron grating, and their locks, therefore, much exposed to violent attacks by desperate criminals, experience has usually pronounced in favor of wrought-metal locks as safer—because not so readily broken by heavy blows—than cast-metal locks. Such locks are, however, expensive to manufacture and repair, and, while they may not readily be broken, they can readily be indented, bent, and deranged, so as to require replacing or repairing, and thus loss and inconvenience are frequently occasioned in public prisons.

In view of these difficulties and objections we propose to employ cast-metal locks, and to secure them in the grating, and shield them there in such a way as to gain all of the advantages of wrought-metal locks, and at the same time to do away, in a very large measure, if not entirely, with their disadvantages, thus compassing all of the present economy of manufacture and capacity of resistance to impact incident to both species of locks, and attaining a degree of safety and durability superior to that arising heretofore from either.

We propose, furthermore, to provide a convenient and instantaneous means of locking, to be applied to the lock-bolt in such a manner as to operate it by mere touch without the use of a key, and also to serve as a notice or tell-tale to warn prison officials when the lock is unlocked.

To increase the security of prison-locks, as thus indicated, our improvements consist in two principal features: First, a spider or open frame-work of metal formed around the lock-case and projecting from it, somewhat like spokes from the hub of a wheel, to fill the opening through the grating in which the lock

is located; second, a supplemental wrought-metal shield or casing for the lock, covering it and the spider, front and back, at all exposed points.

Referring now to the accompanying drawings in aid of a more minute description of our improvements, Figure 1 is a side elevation of our improved lock, with one of the wrought-iron side or guard plates removed to show more clearly the cast-iron lock-case and spider-frame beneath it. Fig. 2 is a vertical longitudinal section on the line 1 1 of Fig. 3. Fig. 3 is a horizontal section on the line 2 2 of Fig. 1. Fig. 4 is a perspective view in vertical section, showing the spring stop or trip and its details more clearly; and Fig. 5 shows a modification of the spring stop or trip.

A indicates a section of a grated prison-door, having a suitable opening formed between its right-angular grate-bars for the reception of a lock. This opening is made purposely larger than the lock-case, in order to accommodate its surrounding frame-work. However, as the usual method of making this opening is to cut away a portion of one or more of the vertical grate-bars, it frequently happens that it becomes unavoidably larger than necessary to accommodate a lock-case of reasonable size. Hence, as the frame-work can readily be cast of any desired dimensions, its use, in addition to its other advantages, obviates the necessity of making the lock-cases unnecessarily large.

B indicates the lock-case proper, of a size just sufficient to contain the bolt and tumblers. C indicates the surrounding spider or frame-work, which may be cast with the lock-case or separately, and which is provided with a vertical groove, *b*, on one side, to receive one of the vertical grate-bars and aid in holding the lock in place, while the lock-bolt, passing through the door-frame, serves a like purpose on the opposite side. *b'* indicates bolt-holes passing through the spider to receive the bolts of the heavy wrought-metal guard-plates D D, which not only cover the lock and its frame, but project partly over and rest upon the door-frame and horizontal grate-bars.

It will be observed that the spider-arms are beveled alike on the front and back, and the

purpose of this is to dish the lock-case in its frame, so that when the guard-plates D D are bolted on there will be considerable spaces between them and the lock-case, their points of contact being on the margin of the framework and on the door-frame and horizontal grate-bars, as above stated.

This plan of construction enables the opening in the door to be conveniently closed with a minimum of material, and affords excellent means of securing the lock in position, and in the event of violence being attempted the elasticity of the wrought-metal plates constituting the supplemental casing enables them to resist heavy blows without transmitting their force to the internal lock-case. If, however, such blows should be continued until the external plates become much indented, the latter will come in contact with the internal case and its surrounding ribs, and be re-enforced without greatly endangering the lock.

E indicates a plunger projecting from the top of the lock-case far enough, when elevated, to be visible at some distance, and working by means of a spring, F, in a barrel, G. The lower end of this plunger is notched or cut away on both sides, as shown at *e*, Figs. 2, 3, and 4, and works up and down in a slot, H, the outer end of which is wider than the inner end, in a flange on the lock-bolt.

The mode of operation of these parts is as follows: The spring of the lock, it should be noted, always tends to throw it forward into the locked position, where its tumblers will always dead-lock it, and the plunger-spring always tends to keep the plunger elevated. The plunger can only be elevated, however, when the lock-bolt is retracted, because it is only when in that position that the wide or enlarged end of its plunger-slot will be in position to permit the plunger to rise, the relations of the parts being such that when the

lock-bolt is not fully retracted the shoulder on the plunger formed by the cutting away will strike against and underneath one side of the slot; but when the lock-bolt has been retracted the enlarged end of the slot will be in coincidence with the plunger and it will spring up. After this its extreme end not thinned or cut away will be in the slot, and, being too large to enter the narrow part of the slot, will stop the bolt in the unlocked position, so that not even the key will lock it. In this condition, which the protrusion of the top of the plunger will indicate, it is only necessary to press down the plunger by hand to bring the cut-away part into the slot, when the bolt will instantly spring into the locked position.

Fig. 5 illustrates another form of trip, which may, in like manner, be combined with the lock-bolt and serve the same purpose. In this example we attach a spring-catch, I, to the plunger, to engage in a notch, *i*, in the lock-bolt.

Having thus described our invention, what we claim as new, and desire to secure by Letters Patent, is—

1. A lock-case surrounded by a spider or frame-work, substantially as above set forth.

2. The combination of an internal lock-case, a spider, and a supplemental external shield or case, substantially as set forth.

3. The combination of a cast-metal case, and inclosing or covering plates which are not in direct contact with the lock-case, and which shield and protect it, substantially as described.

In testimony whereof we have hereunto subscribed our names:

HENRY R. TOWNE.  
THOMAS F. KEATING.

Witnesses:

C. E. VAIL,  
ELIAS D. OGDEN, Jr.