

J. BURROUGHS.
Feed-Wheel for Grain-Drills.

No. 200,253.

Patented Feb. 12, 1878.

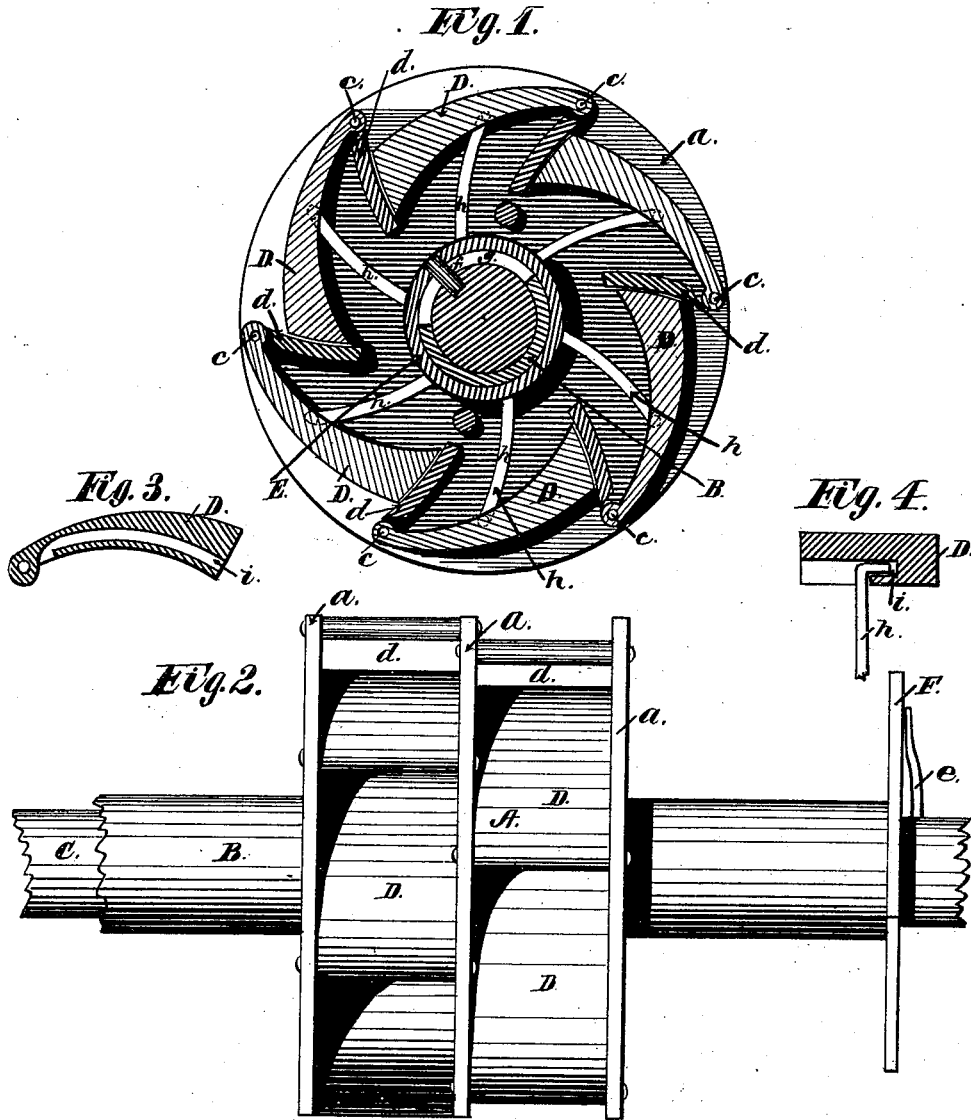

Witnesses;
Chas. M. Peck
Wm. Ritchie

Inventor;
Joseph Burroughs
by his Attys:
Peck & Co

UNITED STATES PATENT OFFICE.

JOSEPH BURROUGHS, OF DAYTON, OHIO, ASSIGNOR OF ONE-HALF HIS
RIGHT TO DANIEL DONSON, OF SAME PLACE.

IMPROVEMENT IN FEED-WHEELS FOR GRAIN-DRILLS.

Specification forming part of Letters Patent No. **200,253**, dated February 12, 1878; application filed
September 3, 1877.

To all whom it may concern:

Be it known that I, JOSEPH BURROUGHS, of Dayton, in the county of Montgomery and State of Ohio, have invented certain new and useful Improvements in Feed - Wheels for Grain-Drills; and I do hereby declare the following to be a full, clear, and exact description of the same.

In the accompanying drawing, Figure 1 is a side elevation of my improved feed-wheel with an end disk removed. Fig. 2 is a front elevation of the same. Fig. 3 is a side elevation of one of the buckets. Fig. 4 is a transverse section of one of the bucket-bottoms.

It is an essential requirement of feed-wheels for grain-drills that they have the capability of discharging varying quantities of seed without changing the speed of the implement or of the feeding devices. This is usually done by varying the capacity of the wheels, the variation being effected by increasing or diminishing their operating width without changing the depth of the buckets. Against this method there is the serious objection that oats and similar grain with long kernels will not adjust themselves in a narrowed chamber, and consequently are often crushed and broken, and thus rendered worthless.

My object is to provide a feed-wheel which shall maintain always the same width, but is so constructed that the depth of the buckets or chambers can be varied at will to sow a greater or less quantity of any sort of grain; and the novelty consists in providing a feed-wheel with adjustable chambers or buckets of unchanging width for varying the quantity sown.

I form my wheel A of two, three, or more parallel disks, *a*, keyed at equal distances apart upon a sleeve, B, which sleeve is so fitted as to be free to turn upon a shaft, C. The spaces between the several disks are divided into any convenient number of compartments, separated by curved radial division-plates *d*, bolted or otherwise rigidly secured between each pair of disks. These plates extend almost, but not quite, to the periphery of the disks, and just over the top of each, at *e*, is pivoted one end of the segment-shaped bucket-

bottom D, of a size just sufficient to fill the opening between a pair of plates, *d*. The relative positions of these segmental pieces D is clearly shown in Fig. 1. To operate these bucket-bottoms I place a collar, E, upon the sleeve B, between each pair of disks, and connect each collar rigidly to the shaft C by means of a pin, *f*, which passes through a circumferential slot, *g*, in the sleeve B. Extending radially from each collar are curved arms *h*, with their top ends bent at right angles to occupy the segmental slots *i* in the bucket-bottoms D, as shown in Figs. 3 and 4. Now, upon partially revolving the sleeve B upon the shaft C, these arms vibrate the bottom pieces D upon their pivotal points *c*, and so increase or diminish the capacity of the buckets.

I do not wish to be limited to the particular arrangement of parts herein described, as they could be varied indefinitely to accomplish the same purpose; for what I consider my invention is, providing a feed-wheel with adjustable compartments upon its periphery, to accommodate varying quantities of grain. Upon a drill my feed-wheel would be confined in a cup of the usual or any suitable construction attached to the under side of the hopper, and having a suitable discharge-orifice to convey the grain to the spouts; and a great advantage gained by my construction is, that the wheel could revolve either way to discharge the grain. The drawing motion might be transmitted to the sleeve B at one end, and its opposite end might be provided with a dial, F, and the shaft C, which revolves with it, might carry an index or pointer, *e*, by turning which the bucket-pieces D would be adjusted to vary the feeding capacity of the wheel.

Having thus fully described my invention, I claim as new—

1. A feed-wheel for grain-drills, having its periphery divided into simultaneously-adjustable compartments of unchanging width, to vary the feeding capacity of the wheel, as set forth.

2. A feed-wheel for grain-drills, consisting of sets of disks *a*, mounted upon a sleeve, B,

and containing between them adjustable segment-pieces D, as and for the purpose set forth.

3. In a feed-wheel for grain-drills, having adjustable buckets, the sleeve B, shaft C, and collars E, united as described, whereby the segmental pieces D can be vibrated through the medium of the arms *h*, or equivalent devices, as set forth.

4. The combination, with the disks *a* and pivoted segment-pieces D, of the division-plates *d*, whereby the grain is prevented from getting within the wheel.

5. In a feed-wheel for grain-drills, the segmental bottom pieces D, having segmental slots *i* on their under sides, and pivoted at one end between a pair of disks, as and for the purpose set forth.

Witness my hand this 31st day of August, A. D. 1877.

JOSEPH BURROUGHS.

Witnesses:

CHAS. M. PECK,
WM. RITCHIE.