

W. I. LUDLOW.
Knob, Latch, and Lock.

No. 200,318.

Patented Feb. 12, 1878.

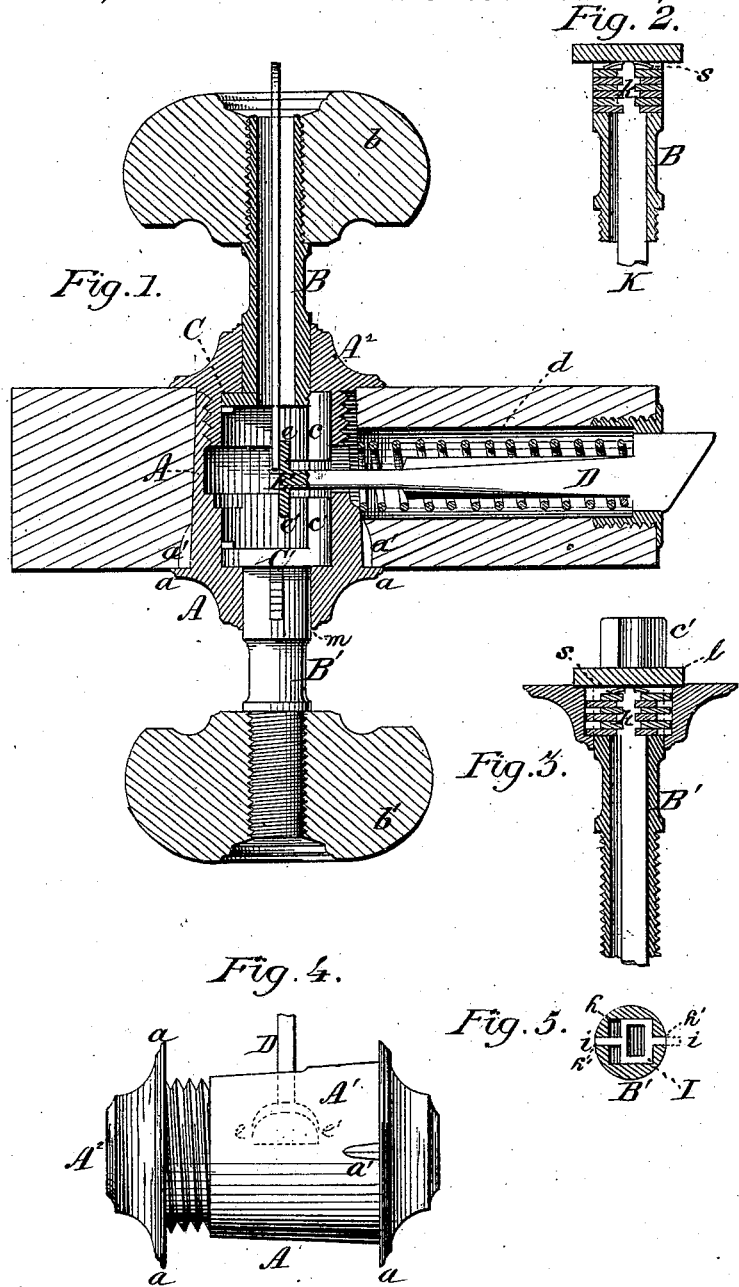

Witnesses:
J. A. Rutherford
W. B. Hale

Inventor: —
W. I. Ludlow
 By his Attorney
James L. Norris

W. I. LUDLOW.
Knob, Latch, and Lock.

No. 200,318.

Patented Feb. 12, 1878.

Fig. 6.

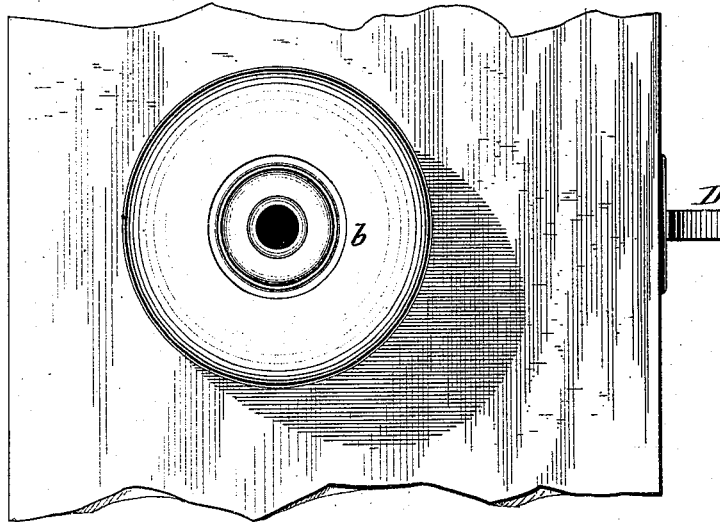

Fig. 7.

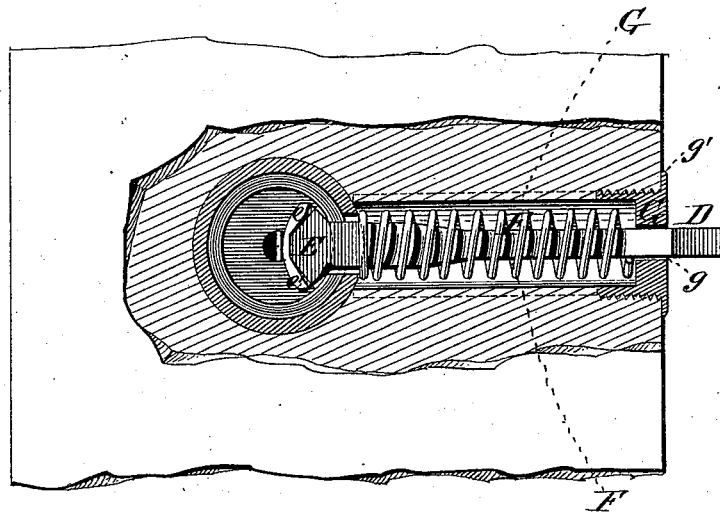

Fig. 8.

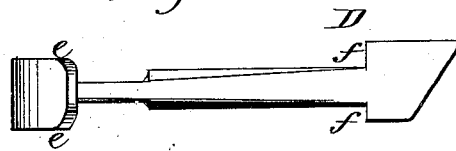
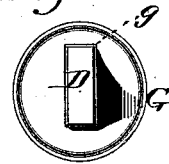

Fig. 9.



Witnesses:
J. A. Rutherford
W. W. Blake

Inventor:
W. I. Ludlow
By his Attorney
James L. Norris

UNITED STATES PATENT OFFICE.

WASHINGTON I. LUDLOW, OF ROCHESTER, NEW YORK.

IMPROVEMENT IN KNOB-LATCH AND LOCK.

Specification forming part of Letters Patent No. **200,318**, dated February 12, 1878; application filed January 11, 1878.

To all whom it may concern:

Be it known that I, WASHINGTON I. LUDLOW, of Rochester, in the county of Monroe and State of New York, have invented certain new and useful Improvements in Knob-Latch and Lock, of which the following is a specification:

This invention relates to that class of door-locks in which a knob-latch and lock are combined; and it consists, first, in the combination, with a hollow or tubular knob-spindle having a suitable opening or openings, of tumblers or bolts arranged within said spindle, and adapted for operation by a suitable key, so that they may be projected through the said opening or openings, to engage with catches or stops which prevent the rotation of the spindle, for the purpose of operating a latch or lock-bolt; second, in a hollow latch-operating spindle, independent of the opposite knob-spindle of its lock or case, and provided with suitable apertures, and having tumblers or bolts inclosed therein, and an operating-knob having a central key-hole, through which a key may be inserted into said spindle to actuate the inclosed bolts or tumblers, for engaging with or disengaging from stops or catches; third, in the combination, with a lock or latch case composed of two cylindrical parts having inner shoulders at their outer ends, of knob-spindles having enlarged inner ends, which will not pass through the shouldered ends of said cylindrical parts, so that the spindles may be inserted through the said parts from the inside thereof before the same are joined together, but cannot be removed outwardly; fourth, in the combination, with a lock-case, of a knob-spindle having a central longitudinal passage opening into the bolt-chamber to the rear end of the bolt when projected, so that a key may be inserted through said spindle and across the path of the bolt, whereby the said bolt is prevented from being retracted; fifth, in the combination, with the lock-case constructed substantially as described, and inclosing a chamber opening into a contracted portion forming a spindle-bearing, of a tubular knob-spindle, inclosing bolt work or tumblers, and having its inner end provided with a head or flange carrying a bolt-operating lug, and closed at its said inner

end, to prevent tampering with the lock-bolt by an instrument inserted through the tubular portion of said spindle; sixth, in the combination, in a lock, of a series of loose tumblers, arranged in contact with each other, and a compressing-spring, whereby said tumblers are held closely together in any position, but permitting lateral independent movement thereof by a suitable key, so that when one or more of said tumblers is moved in attempting to pick the lock other tumblers will be also moved by the friction of adjacent surfaces.

In the accompanying drawings, Figure 1 is a central longitudinal section of the lock-case, one of the spindles, and the bolt-chamber. Fig. 2 is a central longitudinal section of the tumbler and bolt-carrying spindle, showing the key in position to hold the tumbler-bolts in a retracted position. Fig. 3 is a similar view, showing the tumbler and bolt-carrying spindle surrounded by that portion of the case in which are located the bolt-catches. Fig. 4 is a view, in elevation, of the lock and latch case, with the two parts composing it partly unscrewed. Fig. 5 is a diametric section of the tumbler-chamber. Fig. 6 is a view, in elevation, of one of the knobs as when the lock is applied to a door, the bolt shown projected. Fig. 7 is a vertical section, showing the bolt and stops or shoulders at its inner end. Fig. 8 shows the bolt detached. Fig. 9 is an end view of the bolt surrounded by its inclosing-shell.

The letter A indicates the lock-case, composed of the tubular parts A¹ A², held together by the engagement of an internal screw-thread in the part A¹ with an external thread on the part A². Both of these parts are provided with flanges *a*, which are brought snugly against the opposite sides of the door when the parts are screwed together in use, and the part A¹ has splines or ridges *a'* projecting outwardly therefrom, to take into the wood of the door and prevent said part from turning.

In applying the case to a door the part A¹ is inserted first into a suitable aperture, and the other part, at the proper time, is screwed therein. The outer portions of the openings of these parts are contracted, as shown at *m*, to form bearings for the tubular knob-spindles B B', to the outer screw-threaded ends of which are attached the knobs *b b'*, entirely

through which the spindles extend, and the inner ends of said spindles are provided with circular heads or flanges $C C'$, having a diameter equal to that of the chamber of the case A . From each of these heads or flanges projects a segmental lug, c and c' , the outer curved surfaces of which slide against the inner surface of the case when the spindles are rotated.

D is the bolt, which is arranged in an opening, d , cut or bored from the edge of the door, to intersect the aperture in which the case is placed. The inner portion of this bolt is flattened, and projects into the chamber of the case A through an opening in the wall of the part A^1 , and the end of said flattened portion is enlarged edgewise to form a flat head, E , the rear edge of which is curved to correspond to the inner surface of the case.

From this curved edge segmental flanges $e e'$ project laterally in opposite directions, forming a double hook, or two hooks at each side of said head, which stands flatwise between the ends of the lugs $c c'$, which project from the heads or flanges of the spindles B and B' , so that when either spindle is rotated in either direction its lug will strike the projecting flange or hook which is across its path, and thus force the bolt inward. Around said bolt, outside of the case A , is placed a spiral spring, F , one end of which abuts against the wall of said case, and the other against the shoulders $f f$ of the bolt, and serving to project the bolt and keep it out, when not retracted by turning one of the spindles.

In the opening in the door in which the bolt is arranged is placed a thimble or shell, G , having its outer end closed except a diametric slot, g , through which the bolt plays, and upon this end is formed a flange, g' , which should rest snugly against the edge of the door.

As shown in dotted lines, Fig. 7, this thimble or shell may extend inward to the case A , so that the whole of the bolt will be inclosed except the projected portion, and effectually guarded against interference by boring through the door.

The interior of the inner end of the spindle B' is formed into a rectangular chamber, h , as shown in the sectional view, Fig. 5, and from the opposite sides of this chamber slots h' are cut through the wall of the spindle. Within this chamber is arranged a series of tumblers, I , each of which consists of a rectangular frame having a width somewhat less than that of the chamber, but of such length that its ends will slide against the adjacent walls of said chamber. From opposite sides of these tumblers project arms or bolts $i i'$, which extend through the slots in the spindle, and the distance between the outer ends of these slots is approximately equal to the diameter of the spindle, but may be slightly less, though never greater. The arms or bolts of each tumbler in a series may be different in length from those of any other tumbler in the same series, and I prefer to so have them, so that when the outer ends of all said bolts or

arms in a series are even with the periphery of the spindle the edges of no two of the tumblers will coincide or be even within the chamber; nor will their edges coincide when all the said arms or bolts are projected an equal distance through the slots in the spindle. When so projected and the spindle is in its bearing, the bolts or arms extend into recesses k of corresponding width cut in opposite sides of the inner surface of said bearing, and prevent the spindle from turning. The positions of these recesses are such that the tumbler-bolts can only be projected when the spindle B and its lug c' are in position to permit the door-bolt D to be projected, as shown in Fig. 1. When the proper number of tumblers has been placed in the tumbler-chamber a dished metal spring, s , is placed with the edges of its concave side against the outer tumbler of the series, and the chamber is then closed by a disk, l , which is secured by screws to the flange or head C' , and compresses the spring sufficiently to hold the tumblers snugly in contact with each other, but permit their lateral movement to the wards of a suitable key, which will move them simultaneously.

The pressure of the spring should be such that should one tumbler be moved, as in an attempt to pick the lock, the friction of adjacent surfaces would cause other tumblers to move in the same direction, so that the separate displacement of the tumblers to obtain access to the bolt is practically impossible except by a proper key.

The tumblers, with their bolts or arms, are formed from blanks all of which are formed by the same die, and with equal arms of such length that were the blank placed edgewise against the wall of the tumbler-chamber and the end of one arm even with the periphery of the spindle, the other arm would project through its slot beyond the periphery, as shown in dotted lines, Fig. 5. Now, having placed in the tumbler-chamber a sufficient number of blanks to form the required series of tumblers and bolts, a key is selected from a lot for the lock.

I prefer to use a flat key, which should have cut in each edge, at its end, a number of wards equal to the number of tumblers, and the faces of these wards which are to come in contact with the edges of the tumblers should each correspond in extent with the thickness of a tumbler, and each ward should have a corresponding opposite projection, so that the distance across the key between the opposite faces of each ward and its said corresponding projection should equal the distance between the inner edges of each tumbler, as shown at k in the key K , Figs. 2 and 3; but these opposite edges need not be in line with similar edges of any other ward and projection, and I prefer that they should not. Such a key, having its wards and projections variously arranged, being inserted through the spindle and turned at right angles to the edges of the tumblers, the alternate arms of each series

will be moved in opposite directions, and while in this position should all be cut even with the periphery of the spindle, and this will then be the position of the key and tumblers when the spindle is unlocked and permitted to turn in its bearing. Now reverse the position of the key, and the alternate tumblers will be moved again in opposite directions, the reverse of their first movement, and alternate bolts of each series will be projected through the slots of the spindle a sufficient distance to engage into the recess in the spindle-bearing, and this will be the position of the key and tumbler when the spindle is locked and prevented from turning for retracting the door-bolt.

It will be now understood that while the combined length of the two arms or bolts of each tumbler equals that of the arms of every other tumbler in the series, the relative lengths of these arms may be quite different.

The two spindles B B' operate independently of each other, the lugs of both being in front of the flanges or hooks of the bolt, so that either spindle may be rotated in either direction to operate said bolt without disturbing the other. For instance, while the spindle B' is locked from turning, the spindle B may be rotated to retract the bolt. This spindle, which is intended for the inner side of a door, has no locking tumblers and bolts, and the inner end of its tube is not closed, like the end of spindle B', but is left open in order that the key may be inserted therethrough across the path of the door-bolt, as shown in Fig. 1, which renders both spindles inoperative for retracting the bolt, and the door is thus locked from the inside.

What I claim is—

1. The combination, with a hollow or tubular knob-spindle, independent of the opposite knob-spindle of its case or lock, and having a suitable lateral opening or openings, of tumblers or bolts arranged within said spindle and adapted for operation by a suitable key, so that they may be projected through said opening or openings, to engage with catches or stops which prevent the rotation of the spindle, for the purpose of operating a latch or lock-bolt, substantially as set forth.

2. A hollow latch-operating spindle provided with suitable apertures and having tumblers

or bolts inclosed therein, and an operating-knob having a central key-hole, through which a key may be inserted into said spindle to actuate the inclosed bolts or tumblers, for engaging with or disengaging from stops or catches, substantially as described.

3. The combination, with a latch or lock case composed of two hollow cylindrical parts having inner shoulders at their outer ends, of knob-spindles having enlarged inner ends which will not pass through the shouldered ends of said parts, so that the spindles may be inserted through said parts from the inside thereof before the same are joined together, but cannot be removed outwardly, substantially as set forth.

4. The combination, with a lock-case, of a knob-spindle having a central longitudinal passage opening into the bolt-chamber, to the rear of the end of the bolt when projected, substantially as described, whereby a key may be inserted through said spindle and across the path of the bolt, to prevent retraction thereof.

5. The combination, with the lock-case, constructed substantially as described, and inclosing a chamber opening into a contracted portion forming a spindle-bearing, of a tubular knob-spindle inclosing bolt-work or tumblers, and having its inner end provided with a head or flange carrying a bolt-operating lug, and closed at its said inner end, to prevent tampering with the lock-bolt by an instrument inserted through the tubular portion of said spindle, substantially as set forth.

6. The combination, in a lock, of a series of loose tumblers, arranged in contact with each other, and a compressing-spring, whereby said tumblers are held closely together in any position, but permitting lateral independent movement thereof by a suitable key, so that when one or more of said tumblers is moved in attempting to pick the lock, other tumblers will be also moved by friction of the adjacent surfaces, substantially as and for the purpose set forth.

In testimony that I claim the foregoing I have hereunto set my hand in the presence of the subscribing witnesses.

WASHINGTON I. LUDLOW.

Witnesses:

JAMES L. NORRIS,

JAMES A. RUTHERFORD.