

E. WILLIAMS.
Valve-Gear for Steam-Engines.

No. 200,368.

Patented Feb. 12, 1878.

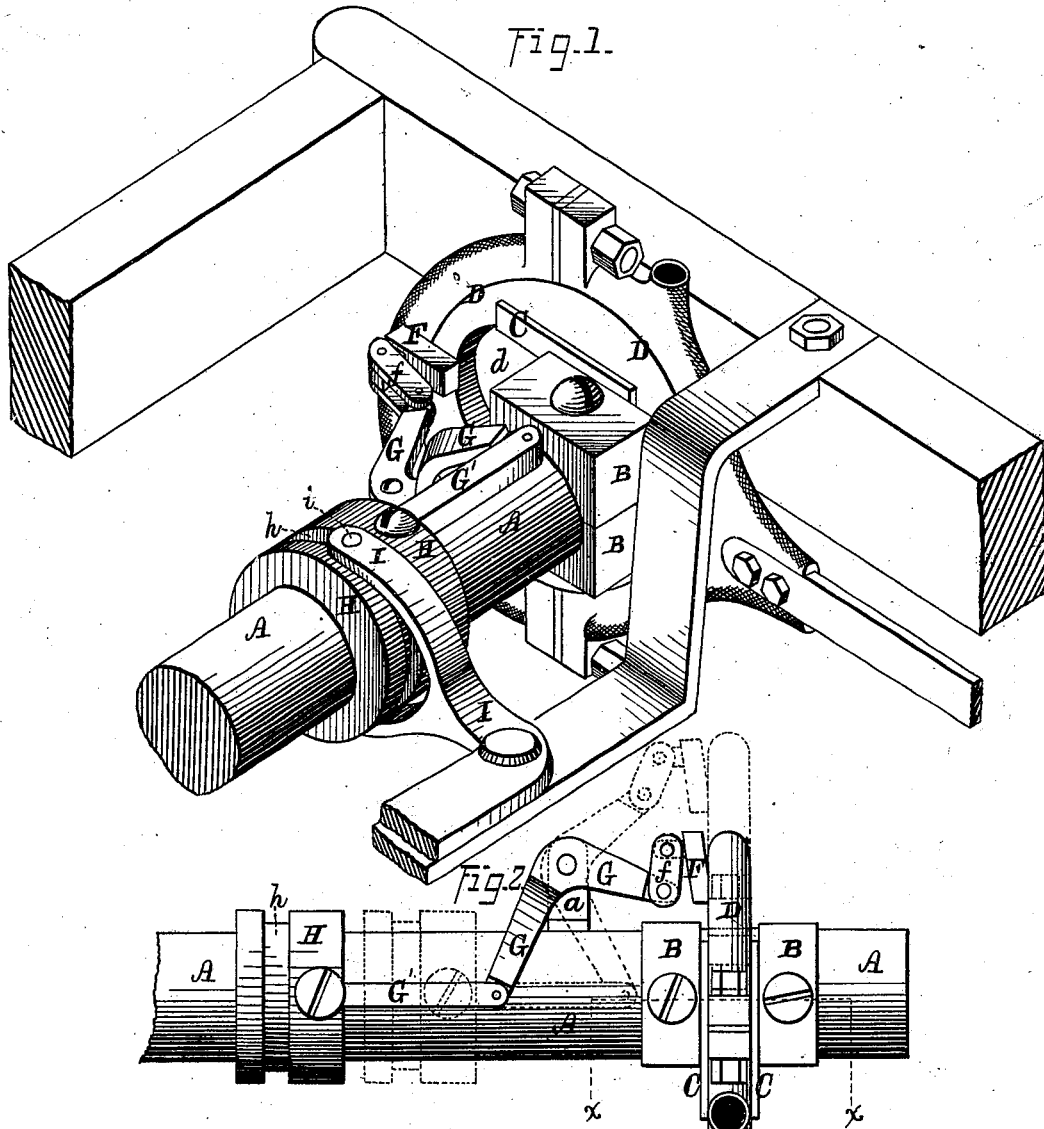

WITNESSES:
Jack Hutchison.
Henry B. Hazard.

INVENTOR:
Edwin Williams.
by C.indle and Co. his
attys

E. WILLIAMS.
Valve-Gear for Steam-Engines.

No. 200,368.

Patented Feb. 12, 1878.

Fig. 3.

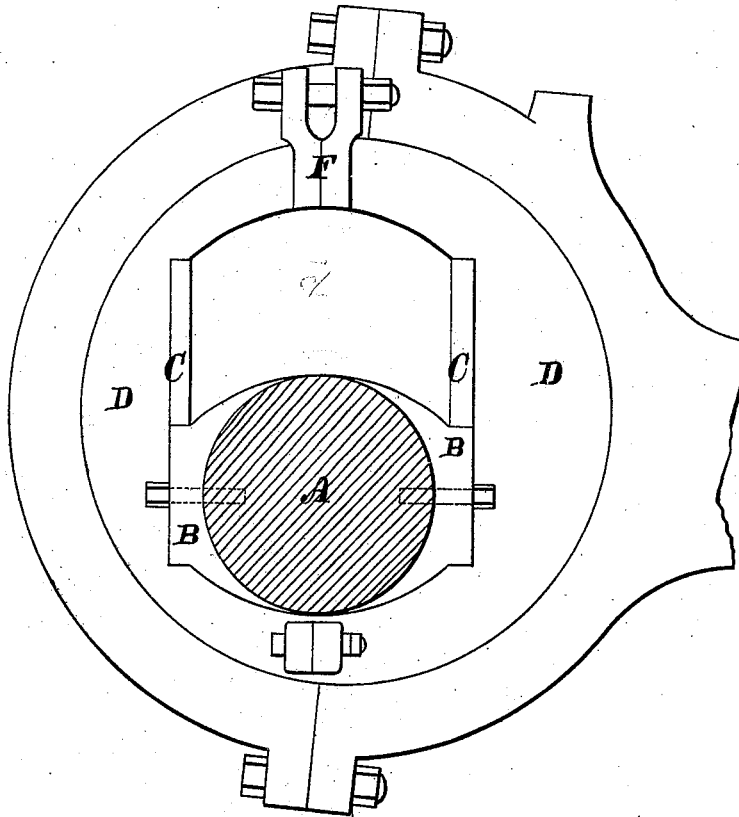
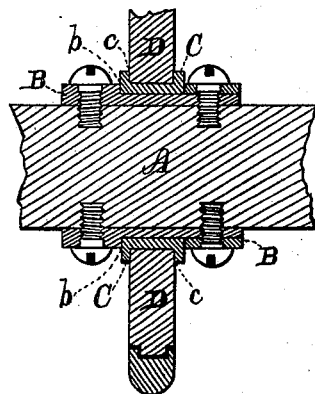

Fig. 4.



WITNESSES:
Jacko Hutchinson
Henry G. Hazard

INVENTOR—
Edwin Williams
by *Quindle & Louis Attie*

UNITED STATES PATENT OFFICE.

EDWIN WILLIAMS, OF NORWICH, NEW YORK, ASSIGNOR TO HIMSELF AND CHARLES W. LAMPHERE, OF SAME PLACE.

IMPROVEMENT IN VALVE-GEARS FOR STEAM-ENGINES.

Specification forming part of Letters Patent No. **200,368**, dated February 12, 1878; application filed July 31, 1877.

To all whom it may concern:

Be it known that I, EDWIN WILLIAMS, of Norwich, in the county of Chenango, and in the State of New York, have invented certain new and useful Improvements in Steam-Engines; and do hereby declare that the following is a full, clear, and exact description thereof, reference being had to the accompanying drawings, making a part of this specification, in which—

Figure 1 is a perspective view of my improved eccentric as applied to the driving-shaft of a locomotive-engine. Fig. 2 is a plan view of the same. Fig. 3 is a side elevation of said eccentric; and Fig. 4 is a central longitudinal section of said shaft and eccentric.

Letters of like name and kind refer to like parts in each of the figures.

The design of my invention is to render unnecessary the employment of links and double eccentrics upon engines for the purpose of reversing the motion of the same; to which end it consists, principally, in the means employed for connecting the eccentric with and rendering the same radially adjustable upon the driving-shaft, substantially as and for the purpose hereinafter specified.

It consists, further, as an improvement in valve-gearing for steam-engines, in the mechanism employed for varying the throw of the eccentric, and for changing its position radially upon the driving-shaft, substantially as and for the purpose hereinafter set forth.

In the annexed drawings, A represents the driving-shaft of an engine, upon which are fastened two blocks, B, that together have a general square form in side elevation, and are provided with a circumferential groove which resembles, in section, an ellipse with its ends cut off, and within each of such ends has provided a right-angled rabbet, *b*, as shown in Fig. 4.

Within each rabbet *b* is fitted a shoe, C, which, within its outer side, is provided with a rabbet, *c*, as shown in Fig. 4.

Encircling the shaft A, blocks B, and shoes C, is an eccentric, D, which is provided with an opening, *d*, that corresponds in width to the distance between the bottoms of the grooves *c* of said shoes, and in length extends nearly

to each edge of said eccentric, and is placed sufficiently at one side of the center to give the necessary lead to the valve.

The eccentric D fits into and closely fills the grooves *c* within the shoes C, while the latter extend to the ends of the opening *d* and closely fills the same longitudinally.

As thus arranged, it will be seen that the eccentric D may be moved in the direction of the length of its central opening *d*, so as to cause its axis to coincide with or to have any desired degree of eccentricity with relation to the axis of the shaft A; and, further, that such eccentricity may be produced upon either side of said shaft at will.

The position of the eccentric with relation to the shaft is varied by means of the following-described mechanism: A pivotal lug, F, is formed upon one side of the eccentric D, at one end of the opening *d*, and to the same is pivoted, by means of a short bar, *f*, one end of a bell-crank, G, which crank is pivoted centrally upon a suitable bearing, *a*, that is secured to and projects radially from the shaft A, said crank being placed in a line with said shaft.

Upon the shaft A, beyond the crank G, is loosely fitted a grooved collar, H, which is capable of being moved lengthwise of said shaft, and is connected with the inner end of said crank G by means of a bar, G', which extends between and has its ends pivoted to said parts, the arrangement being such as to cause the eccentric D to be moved, as described, whenever said grooved collar is moved lengthwise of said shaft.

In order that the collar H may be readily moved upon its shaft by the engineer at his post, a bell-crank lever, I, is pivoted horizontally upon a suitable support, in such position as to bring its shortest arm, which is forked, as shown in Fig. 1, into position to span said collar. A stud, *i*, corresponding in transverse dimensions to the width of the groove *h* of said collar, projects into the same from each end of said forked arm, while a rod is pivoted to the longer arm of said lever, and extends rearward to and is pivoted upon the lower end of an ordinary reverse lever, which completes the mechanism.

By moving the reverse lever in either direction, the lever I, operating upon the collar H and through the same, the bar G', the crank G, the bar f, and the lug F, will cause the eccentric D to be moved radially with relation to the shaft A, so as to vary the amount of its eccentricity or to change such eccentricity to the opposite side of the shaft.

By means of this mechanism it will be seen that a single eccentric is rendered capable of performing the office heretofore performed by two eccentrics and a link, the result being a large saving in expense both of construction and wear.

Having thus fully set forth the nature and merits of my invention, what I claim as new is—

1. The means employed for connecting the eccentric D with and rendering the same radially adjustable upon the shaft A, consisting of the blocks B, secured to or upon said shaft, and provided within opposite edges with rabbets *b*, and the shoes C fitted to and sliding within said rabbets, and secured within oppo-

site sides of the central opening *d* of said eccentric, substantially as and for the purpose specified.

2. As an improvement in valve-gearing for steam-engines, the eccentric D, provided within opposite sides of its central opening *d* with shoes C, which fit within rabbets *b* of blocks B, that surround and are attached to the shaft A, the connecting-bars *f*, the bell-crank lever G, the connection G', the grooved collar H, and the lever I, said parts being constructed and combined to cause said eccentric to be moved radially upon said shaft whenever said lever I is moved horizontally upon its pivotal bearing, substantially as and for the purpose set forth.

In testimony that I claim the foregoing I have hereunto set my hand this 10th day of July, 1877.

EDWIN WILLIAMS.

Witnesses:

W. MERRIFIELD,
R. B. PRINDLE.