

B. JONES

Harness.

No. 200,399.

Patented Feb. 19, 1878.

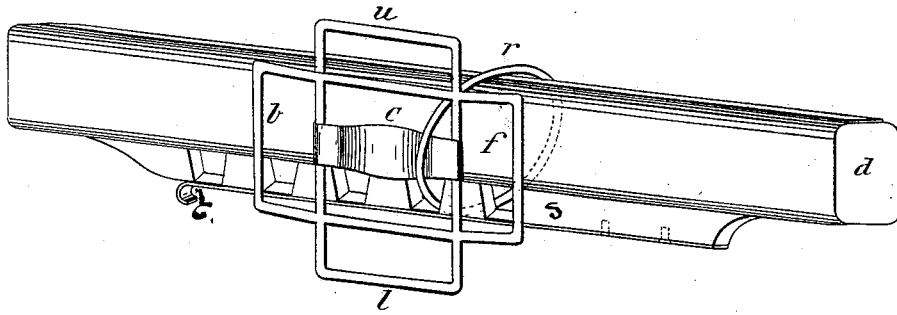

*Attest*

*S. K. Hogue*  
*James Long, J.P.*

*Inventor*

*Batt Jones*

# UNITED STATES PATENT OFFICE.

BATT JONES, OF ROCK MART, GEORGIA.

## IMPROVEMENT IN HARNESS.

Specification forming part of Letters Patent No. **200,399**, dated February 19, 1878; application filed November 19, 1877.

*To all whom it may concern:*

Be it known that I, BATT JONES, of the town of Rock Mart, in the county of Polk, in the State of Georgia, have invented a new Improvement in Single Horse Harness, and the manner of attaching the horse-power to all shaft vehicles; and I do hereby declare that the following is a full and exact description thereof, reference being had to the accompanying drawing, and to the letters of reference marked thereon.

My invention consists of a suitable metallic frame provided with side and end loops and a central transverse curved bar, in combination with a shaft-holding plate and spring, as hereinafter described.

In the drawing, *u* represents the upper or back-band loop; *l*, the lower side loop for receiving the belly-band; *f*, the forward end loop for the hame-tug attachment; *b*, the rear loop for holding the breeching and holdback-straps, and *c* the curved central transverse bar for holding the draft-ring *r*.

Attached to the under side of the shaft is a metallic plate, *s*, provided with outer face notches or depressions, arranged at suitable distances from each other. Secured at one end of this plate is a flat spring, *t*, resting upon and covering the outer or notched face

of the plate. One end of this spring is left free, so as to permit the ring *r* to be slipped onto the shaft of the vehicle, and to pass or drop into any one of the notches, when, by the force of the spring, it will be held in place.

By reason of the notches in the shaft-plate, adjustability is provided, which adapts the shaft of the vehicle to animals of different sizes, and the ring, which passes around the shaft and rests in one of the notches when in use, serves as a medium for draft, and avoids the necessity of the long trace, which is a saving of expense, in the manufacture of harness, of much importance.

This draft arrangement, above described, is applicable to any style of harness. The ring in all cases dispenses with the long trace.

I claim as my invention—

As an improvement in harness, the draft attachment consisting of the metallic frame provided with the side loops *u*, *l*, end loops *b*, *f*, and the curved transverse bar *c* with its ring *r*, in combination with the notched plate *s* and its covering-spring *t* attached to the shaft, all as and for the purpose set forth.

BATT JONES.

Witnesses:

H. KINGSBERRY,  
W. N. STRANGE.