

C. C. JEROME.  
 Stuffing-Box for Steam-Engines.

No. 200,458.

Patented Feb. 19, 1878.

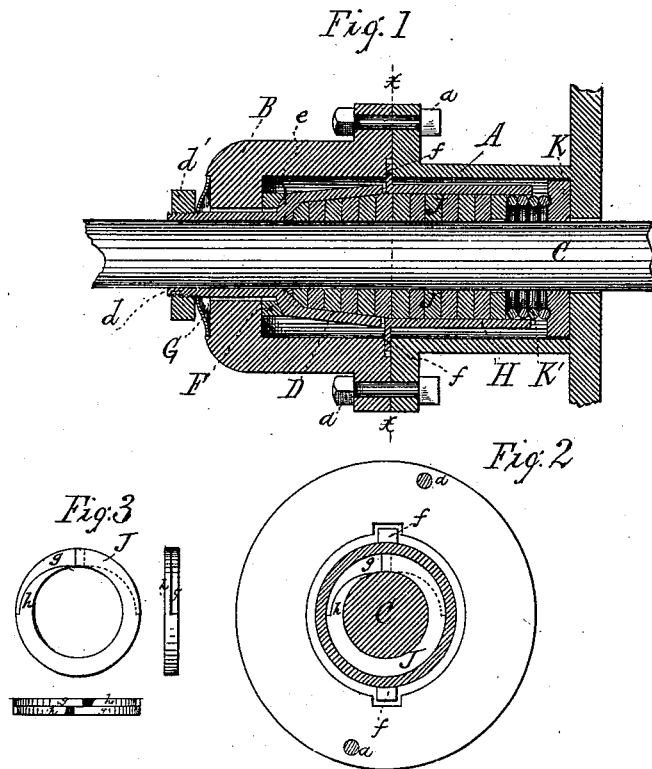

Witnesses  
 G. B. Hoffman  
 N. Cowles

Inventor  
 Charles C. Jerome  
 By Girdley & Sherburne  
 Attys

# UNITED STATES PATENT OFFICE.

CHARLES C. JEROME, OF CHICAGO, ILLINOIS.

## IMPROVEMENT IN STUFFING-BOXES FOR STEAM-ENGINES.

Specification forming part of Letters Patent No. **200,458**, dated February 19, 1878; application filed February 6, 1878.

*To all whom it may concern:*

Be it known that I, CHARLES C. JEROME, of Chicago, in the county of Cook and State of Illinois, have invented new and useful Improvements in Stuffing-Boxes for Steam-Engines; and I do hereby declare the following to be a full, clear, and exact description thereof, which will enable others skilled in the art to which my invention appertains to make and use the same, reference being had to the accompanying drawing, forming part of this specification, in which—

Figure 1 represents a longitudinal central section of a stuffing-box for steam-engines embodying my said invention. Fig. 2 represents a transverse section of the same, showing those parts which are at the left hand of the line *x x* drawn across Fig. 1; and Fig. 3 represents a plan and edge views of one of the packing-rings detached from the stuffing-box.

Like letters of reference indicate like parts.

My invention relates to that class of stuffing-boxes in which metal packing-rings are employed for the purpose of packing the piston-rod and valve-stems of steam-engines; and the object of my invention is to improve the construction of the same, so as to render their operation more complete; and to that end my invention consists in the arrangement of the several parts, as hereinafter more fully set forth and claimed.

In the drawing, A represents the ordinary stuffing-box, which is formed on the cylinder-head in the usual manner.

B represents an elongated cap or supplemental stuffing-box, which is secured to the outer end of the stuffing-box A by screw-bolts *a a*, passing through its flange into the flange of the stuffing-box, as shown in Fig. 1, and is provided with an internal chamber or bore, the diameter of which corresponds with or is equal to the diameter of the bore of the stuffing-box.

C represents the piston-rod, which passes centrally through the stuffing-box A and cap B in the usual manner.

D represents a conical or slightly-tapering cylinder, which is loosely fitted within the cap or supplemental stuffing-box B, and so as to admit of a lateral movement therein, and is provided at its end toward the steam-cylinder

with a conical or tapering bore, through which the piston-rod passes, which bore is of the proper diameter to receive the metal packing-rings which encircle the piston-rod. This cylinder is provided at its end opposite to the steam-cylinder with a sleeve, *d*, which encircles the piston-rod, and extends through and slightly beyond the end of the cap or supplemental stuffing-box, as shown in Fig. 1, and is screw-threaded externally at its outer end to receive an adjusting-nut, *d'*, and is adjusted to the piston-rod so as to admit of a lateral movement therewith.

The end of the cylinder D, at its junction with the sleeve *d*, is slightly greater in diameter than the external diameter of the sleeve, and is rounded off, so as to form a convex spherical shoulder, *e*.

F is an annular metal packing-ring, which is loosely fitted around the sleeve *d*, between the shoulder *e* and end wall of the cap or supplemental stuffing-box, and is ground or fitted to the inner face of the said wall, so as to form a steam-tight joint, and is provided at the opposite end with a concavo-spherical depression to receive the spherical surface of the shoulder *e*, the object of which is to allow the sleeve and cylinder to move laterally with the piston-rod, and to admit of a slight rocking movement of the cylinder, so as to allow the sleeve and cylinder to adjust themselves to the plane of the rod, should the latter be out of line, and without opening the joints between the ring and its corresponding parts, so as to admit of the escape of steam through the opening in the end of the cap. G represents an annular spring-plate or washer, which is interposed between the back of the adjusting-nut *d'* and end of the cap or supplemental stuffing-box, and through which the sleeve *d* passes.

The object of providing the cylinder D with the sleeve *d*, and extending the latter through the end wall of the supplemental stuffing-box, and arranging the adjusting-nut on the outer end of the sleeve, is to provide means of holding the spherical shoulder on the cylinder within the depression, forming its seat in the ring F, and so as to compress the ring against the inner surface of the end wall of the supplemental stuffing-box, and to prevent the cyl-

inder containing the packing-rings from being drawn back and off its seat in the ring by the receding movement of the piston-rod.

H represents a cylindrical sleeve, which is loosely fitted within the stuffing-box A, and extends inward to a point near the end wall of the same, and is provided at its outer end with lugs *f f*, which are loosely fitted within corresponding recesses formed in the inner end of the supplemental stuffing-box, by which means the said sleeve is held in its proper place, and so as to admit of a central movement with the piston-rod.

The diameter of the bore of this sleeve is equal to the greater diameter of the bore in the cylinder D, so that the packing-rings contained within said sleeve will readily pass therefrom into the cylinder.

J represents the packing-rings, which are made of metal, and are fitted around the piston-rod within the cylinder D and sleeve H, as shown in Fig. 1. These rings are each severed at one point, and are cut away on the outer edge and on alternate sides, so as to form a rabbet, *g*, on each side of the severed point, and of a depth equal to one-half the thickness of the ring, and so that the shoulder *h* of each rabbet will be eccentric to the base of the ring, and will terminate in a feather-edge at a point near where the ring is severed.

The ends of each ring, at the point where the ring is severed, lap past each other, and pass into the rabbet on the opposite side of the severed point and beyond the feather-edge of the shoulder, so as to allow the rings to contract and enter the tapering bore of the cylinder as they are worn away on the inner surface by the friction of the piston-rod, and thus render the joint in the rings steam-tight at all times. By arranging the splice in the rings, as described, the feather-edges of the shoulders are prevented from being broken away or drawn out of place by the friction of the piston-rod.

K represents an annular plate, which is fitted

within the stuffing-box A, and through which the piston-rod loosely passes. K represents an adjusting-spring, which is loosely fitted within the sleeve H around the piston-rod, between the packing-rings and the plate K. The arrangement of this spring is such as to hold the packing-rings within the cylinder D against the receding movement of the piston-rod, the rings being forced from the sleeve H into the cylinder by the pressure of steam against them as the rings at the outer end of the cylinder are worn away by the friction of the piston-rod.

The arrangement of the sleeve H is such as to admit of a slight lateral movement with the cylinder D, or independent of the cylinder, the object of which is to allow the several parts to more perfectly adjust themselves to the piston-rod.

Having thus described my invention, what I claim as new, and desire to secure by Letters Patent, is—

1. The combination, with the supplemental stuffing-box B and packing-ring F, of the tapering cylinder D, having the spherical shoulder *e* seated within its recess in the ring, and provided with the sleeve *d* and nut *d'*, for preventing the cylinder from being drawn off its seat by the receding movement of the piston-rod, as specified.

2. The combination, with the tapering cylinder D, of the sleeve H, containing a portion of the packing-rings, and made laterally adjustable with or independent of the cylinder, substantially as and for the purpose specified.

3. The packing-rings J, severed at one point and rabbeted on the outer edge and on alternate sides, to form the shoulders *h* eccentric to the bore of the ring, substantially as and for the purpose specified.

CHARLES C. JEROME.

Witnesses:

G. R. HOFFMAN,

N. H. SHERBURNE.