

R. M. LAMSON.  
Pitman Connection.

No. 200,461.

Patented Feb. 19, 1878.

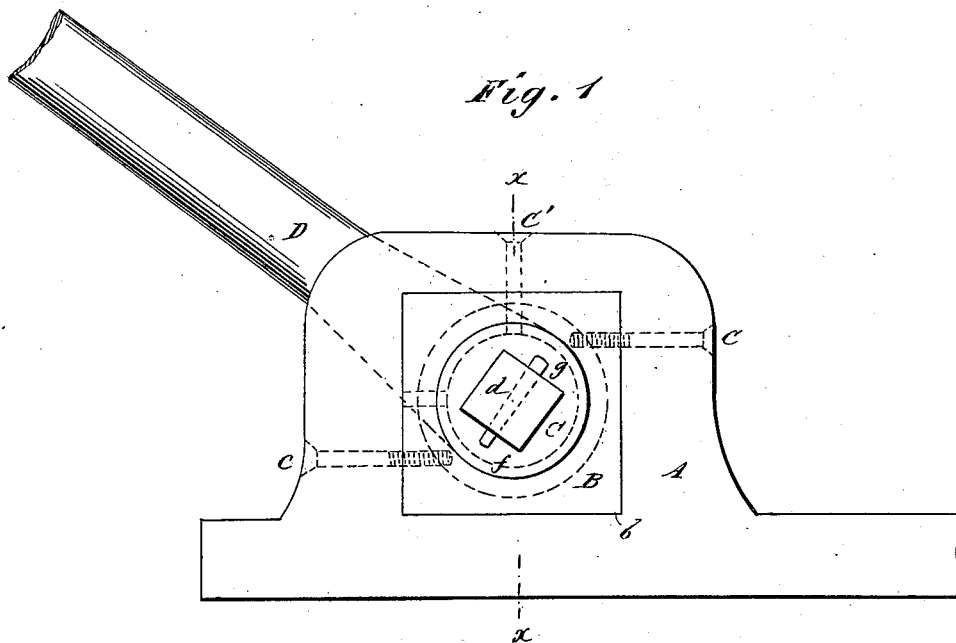
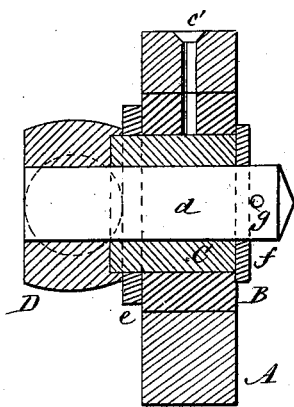

Fig. 2



WITNESSES:

*C. Neveu*  
*C. Sedgwick*

INVENTOR:

*R. M. Lamson*  
BY *Munn & Co.*

ATTORNEYS.

# UNITED STATES PATENT OFFICE.

RODOLPH M. LAMSON, OF VEVAY, INDIANA.

## IMPROVEMENT IN PITMAN-CONNECTIONS.

Specification forming part of Letters Patent No. **200,461**, dated February 19, 1878; application filed January 8, 1878.

*To all whom it may concern:*

Be it known that I, RODOLPH M. LAMSON, of Vevay, county of Switzerland, and State of Indiana, have invented a new and Improved Pitman-Connection, of which the following is a specification:

Figure 1 is a side elevation. Fig. 2 is a transverse section taken on line *xx* in Fig. 1.

Similar letters of reference indicate corresponding parts.

My invention relates to pitman-connections for mowers and other machinery; and it consists in a bushing fitted to a square aperture in the knife-head, and bored to receive a cylindrical thimble, which is fitted to the square shank of the pitman.

The object of the invention is to provide a pitman-connection that may be readily repaired by removing the worn or broken parts and replacing them with new parts.

Referring to the drawing, A is the head of a mower-knife, in which there is a rectangular opening, *b*, for receiving the bushing B, said bushing being bored cylindrically for receiving the thimble C. The bushing B is secured in the head A by two screws, *e*, which pass through the edges of the head into the bushing from the top and two opposite edges. *e'* is an oil-hole. The thimble C is longer than the thickness of the bushing B, and is apertured longitudinally, and fitted to the square shank *d* of the pitman D. The pitman is recessed to receive the end of the thimble, and between the side of the pitman and the side of the bushing a leather washer, *e*, is placed,

and upon the square shank *d* of the pitman D a metallic washer, *f*, is placed, which is a little larger in diameter than the thimble *c*. A hole is drilled transversely through the shank *d* for receiving the pin *g*, by which the pitman and thimble are held in place in the bushing.

When the thimble and bushing become worn or broken, they may be easily removed and replaced by perfect ones.

In some cases the square bushing B may be dispensed with, and the thimble C may be used in connection with a pitman having a square shank, and fitted to a circular hole in the head of the mower-knife.

I have described this connection as being applicable to the pitman of a mower; but I do not confine myself to this application, as it may be applied to the poles and shafts of carriages, and the wheels and axles of carriages may be fitted up in a similar way; also car-axles, crank-pin journals on steam-engines, and journal-bearings in general.

Having thus fully described my invention, I claim as new and desire to secure by Letters Patent—

The metallic thimble C, projecting into an annular recess of pitman D, and held therein, around the pitman-journal *d* and to the detachable bushing B, by washer *f* and pin *g*, as and for the purpose specified.

RODOLPH M. LAMSON.

Witnesses:

SYLVANUS LANHAM,  
L. W. GOLEY.