

G. A. LEIGHTON.
Circular Knitting Machine.

No. 200,463.

Patented Feb. 19, 1878.

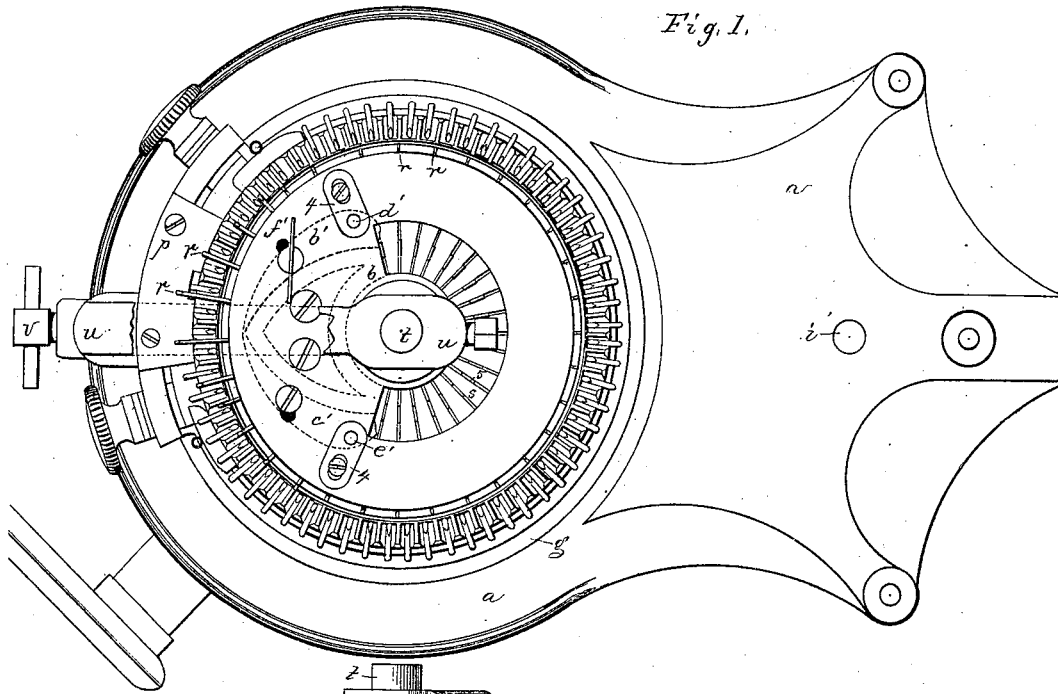

Fig. 1.

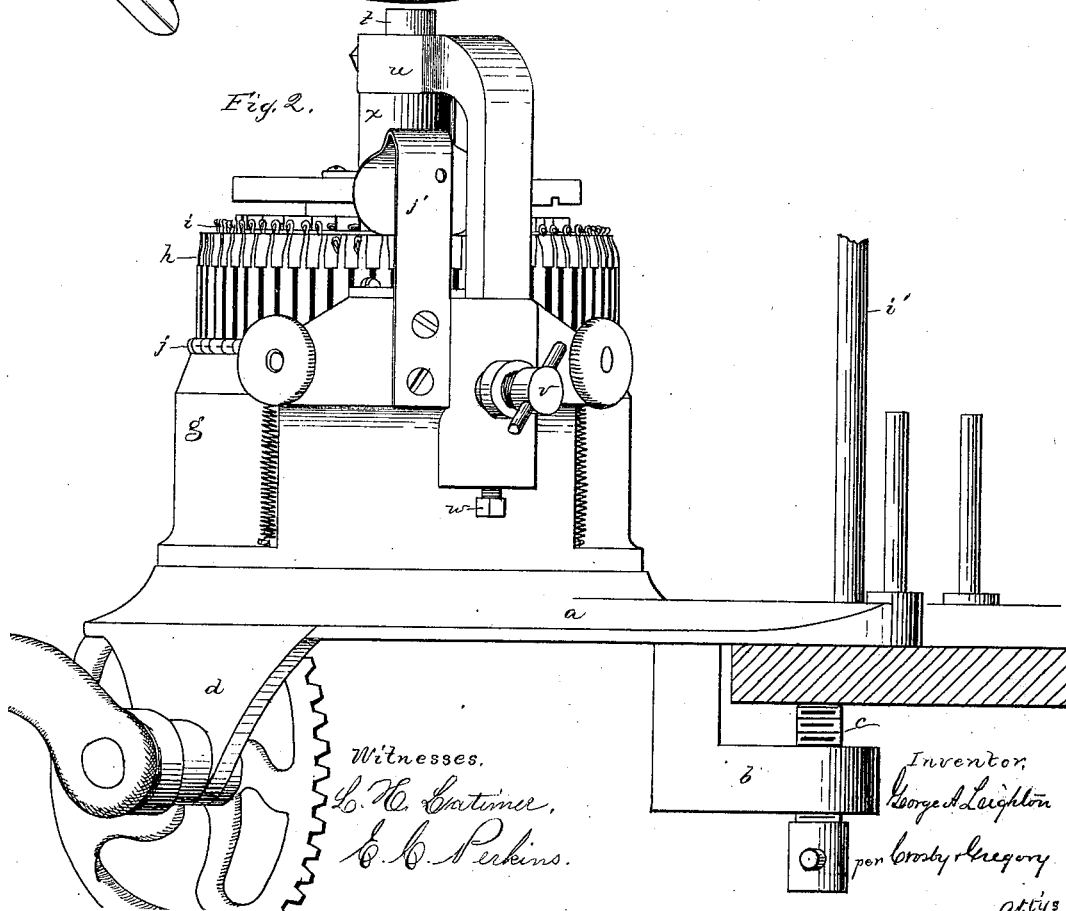

Fig. 2.

Witnesses,
 G. W. Eastman,
 C. B. Perkins.

Inventor,
 George A. Leighton
 per Crosby & Gregory

attys

G. A. LEIGHTON. Circular Knitting Machine.

No. 200,463.

Patented Feb. 19, 1878.

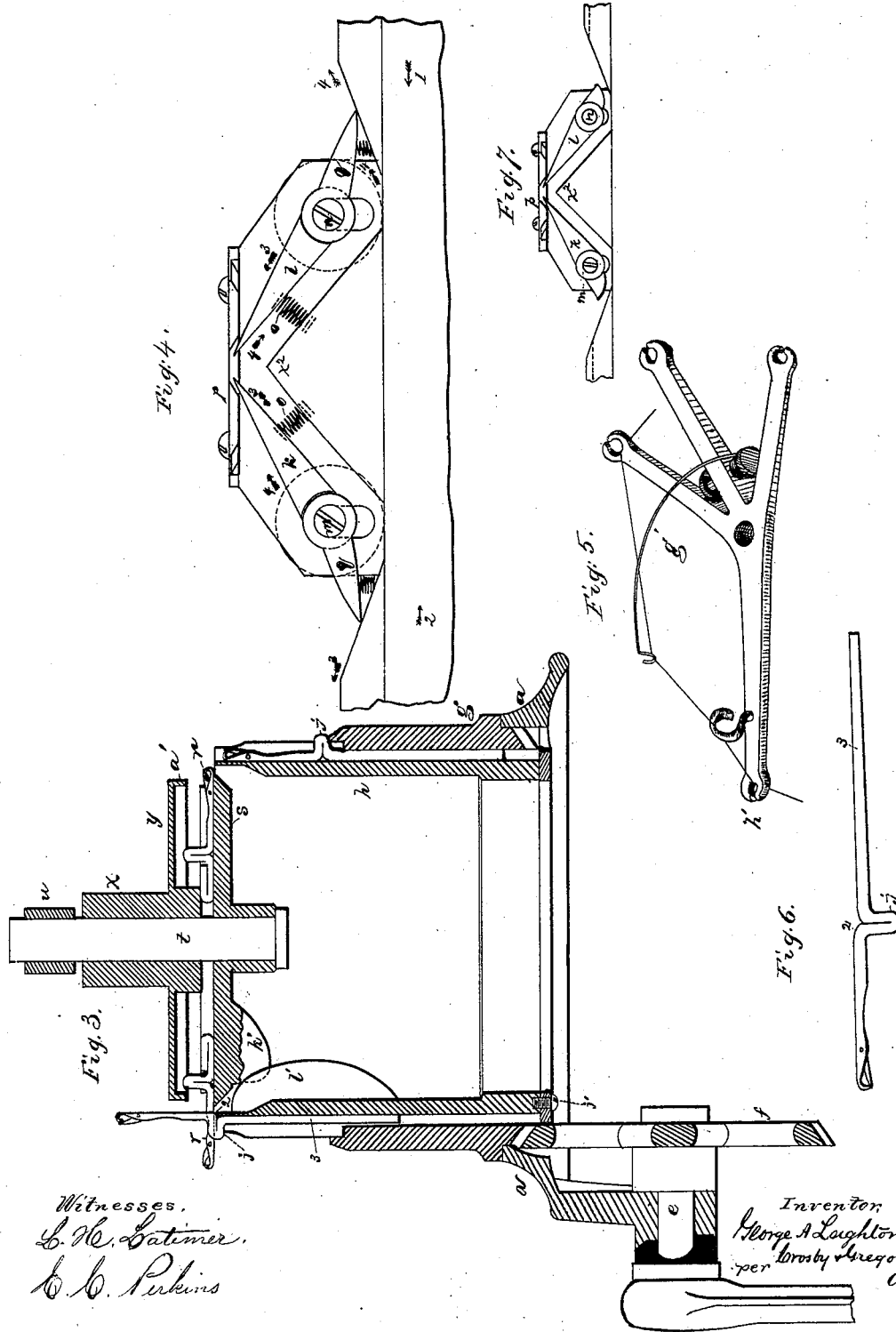

Witnesses,
L. W. Catimer,
C. C. Perkins

Inventor
George A. Leighton
per *Ormsby Gregory* *Att'y.*

UNITED STATES PATENT OFFICE.

GEORGE A. LEIGHTON, OF MANCHESTER, NEW HAMPSHIRE, ASSIGNOR OF ONE-HALF HIS RIGHT TO WILLIAM COREY, OF SAME PLACE.

IMPROVEMENT IN CIRCULAR-KNITTING MACHINES.

Specification forming part of Letters Patent No. **200,463**, dated February 19, 1878; application filed May 7, 1877.

To all whom it may concern:

Be it known that I, GEORGE A. LEIGHTON, of Manchester, in the county of Hillsborough and State of New Hampshire, have invented an Improvement in Circular-Knitting Machines, of which the following is a specification:

This invention relates to improvements in knitting-machines of the circular class employing a series of latched needles.

The cam-cylinder is arranged to be rotated to knit tubular web, or to be reciprocated to fashion the web, or for knitting the heel and toe parts of stockings, as now commonly practiced on hand-operated circular machines.

This invention has for its object an improvement in the construction of the cams, whereby the yarn-carrier may be attached to the cam-cylinder positively, instead of being attached to a separate ring, to be operated independently when the heel and toe are being made, or when the machine is reciprocated.

In this my machine the butts of the needles are elevated and depressed, when the cylinder moves in opposite directions, by means of two pivoted cams, each operating in turn by reason of the butts being alternately above and below it, according to the direction of movement of the cam-cylinder to elevate or draw down the needles.

The invention also includes a new construction of needle, whereby it is adapted to rest upon the top of the needle-bed when elevated. It also includes an annulus provided with a rim and open center, and a cam to permit the manipulation of the dial-needles with reference to the cylinder-needles, as hereinafter described. It also includes the combination, with the top of the cam-cylinder, of a series of needles provided with tail-pieces, and having butts of a length sufficient to project beyond the cylinder, so that they may be engaged by the hand of the operator or otherwise, and be quickly lifted into position when it is desired to shape the work, this being done instead of pulling up the needles by their hooks, as now commonly practiced.

Figure 1 represents, in plan or top view, one of my improved knitting-machines; Fig. 2, a side elevation thereof; Fig. 3, a section show-

ing one of the needles lifted and another depressed; Fig. 4, a view of the cams of the cam-cylinder; Fig. 5, a detail of such a thread-guide and take-up as I prefer to use; Fig. 6, one of the needles, and Fig. 7 a modification of the cams.

The bed *a* of the machine has a lug, *b*, to receive a fastening-screw, *c*, and a lug, *d*, to receive the shaft *e*, provided with a pinion, *f*, adapted to engage teeth on the lower portion of the cam-cylinder *g*, so that such cylinder may be rotated or otherwise moved in the desired direction. The needle-bed *h*, provided with grooves, as usual, for the needles *i*, is fixed to the bed by screws *j* or otherwise. The upper portion of the cam-cylinder is of a thickness less than the length of the butts *j*, projecting beyond the needle-bed and resting on the top of the cylinder, so that the operator may engage the butts by hand or otherwise, and elevate the needles in their grooves whenever it is desired to narrow or widen, or for ornamental knitting. The needles, near their butts, are projected backward, as at 2, beyond their tail-pieces 3, whereby the needles, when drawn up, are, under the action of the weight of the knitted fabric, thrown toward the center of the cylinder, so as to lodge the portion 2 upon the top of the needle-bed, whereby the needles are kept elevated. The needles will remain in an elevated position, even though the loops are not upon them.

The main cams *k l*, for operating the needles, are pivoted at their lower ends *m n*, and their upper ends are pressed by springs *o* into a space in a cap-piece, *p*, it receiving the points of the cams, so that the butts of the needles passing between the points will not catch and injure or move them improperly. The pivots of these cams are made adjustable vertically, to lengthen or shorten the loop, and consequently regulate the closeness of the knitting.

When the cam-cylinder is moved in the direction of arrow 1, Fig. 4, the needle-butts ride up over cam *l* and down under cam *k*, as denoted by arrow 3. When the cylinder moves in the direction of arrow 2, the butts travel up over cam *k* and down under cam *l*, as denoted by arrow 4.

It will therefore be noticed that the oppo-

site sides or faces of each cam at times serve, when the cam moves in one direction, as an elevating-cam, and when the cam moves in an opposite direction the other or opposite side operates as a depressing-cam.

It will also be noticed that the points of the cams $k l$ rest upon the portion x^2 , or against the plate p , as the butts of the needles pass over or below them.

In the form of my invention represented in Fig. 4, I have shown small pointed lifters g , to lift the butts of the needles above the pivots of the cams; but instead of these lifters I may place the top of the cam-cylinder and the pivots of the cams $k l$ with such relation to each other, substantially as shown in Fig. 7, that the butts of the needles will pass under such pivots when moving in one direction, and in the opposite direction the top of the cylinder will leave the butts high enough to meet the upper faces of the cams above their pivots.

In ordinary circular machines operated by hand, a mock rib is made by removing a portion of the needles, this mock rib being useful for the tops of stockings.

In my machine I propose to knit regular rib tops, using therefor cylinder and horizontally-reciprocating dial-needles. The dial-needles r are arranged in grooves in a dial-plate, s , placed loosely upon a spindle, t , secured at the end of an overhanging arm, u , connected with the cam-cylinder by means of a set-screw, v , and made adjustable as to its height by a screw, w . This spindle has secured to it a hub, x , provided with an annulus, y , having a rim, a' , about its outer edge, to serve as an outside stop to prevent the dial-needles being drawn completely outward from their grooves. This annulus has attached to it separable cams $b' c'$, pivoted at $d' e'$, the pivots being connected with adjustable blocks 4. Each cam will, preferably, be provided with a set-screw, f' , adapted to extend through a slot in the annulus or dial-plate, to permit the points of the cams to be held, as shown in dotted lines, Fig. 1, or to be moved so that the point of one may project beyond the point of the other, to permit it to engage the butts of needles previously drawn out, so as to draw such needles back to be operated by the cams for regular knitting.

When the machine is being reciprocated the yarn is placed in the loop of the take-up g' , so as to properly control its slack. The yarn extends from the eye h' in an arm projecting laterally from the top of a standard, i' , to the hole in the yarn-carrier j' , it being fixed to the cam-cylinder g .

The cylinder-needles may be operated separately and produce a cylindrical or flat web, in the usual way.

To knit a stocking having the top, and, if desired, other portions, ribbed, I proceed as follows: The work is "set up" on the cylinder-needles in any usual way, and the dial is placed in position within the circle of machine-

needles, the dog k' on the dial-bed s fitting between two lugs, l' , side by side within the bed h , and both sets of needles are operated as in ordinary circular rib machines.

If only a rib top is desired, the machine is stopped at the proper time, the loops on the dial-needles are transferred to the cylinder-needles, and the dial-needles are drawn completely back, so that their butts will fall in the range of the groove 6, (see Fig. 1,) and then the dial may or may not be removed.

If it is desired to knit a ribbed leg, the ribbing is continued to the proper length.

If it is desired to knit a ribbed heel and instep, both the cylinder and dial needles, holding the loops to form the instep, are drawn up and out of action, the butts of the cylinder-needles then resting upon the top of the bed h , and the butts of the dial-needles resting against the rim a' . The needles left in knitting position are sufficient to properly start the heel. The knitting is now continued, the cam-cylinder and the dial-cam being reciprocated and operating their needles as usual. If the heel is to be square, the knitting is continued upon the same number of needles until a flap of the desired length has been made. If the heel is to be narrowed and then widened, the needles of both sets are progressively drawn out of action until the narrowest course has been knitted, and then they are moved back into action until the heel is formed, and then all the needles are thrown back into operative position. At this time, if it is desired that the under part of the foot remain plain, the loops of the dial-needles used in forming the heel are transferred to the cylinder-needles opposite them, and the dial-needles are pushed completely back out of reach of their operative cam, and then the continuous rotation of the machine will make a tube ribbed upon one portion and plain upon another portion of its surface.

It is obvious from the foregoing description that the entire heel may be knitted plain instead of ribbed. Any portion of the heel may be ribbed or left plain.

When the ribbed knitting has proceeded as far as is desired for the ribbed instep or upper part of the foot, the loops of all the dial-needles are transferred to the cylinder-needles, and thereafter the rest of the foot to and including the toe will be formed by the cylinder-needles only, in the usual way well known to operators of knitting-machines.

When the cylinder-needles are elevated out of operative position their butts pass entirely above the top of the plate p , covering the points of the cams. The lugs $k' l'$ have between them sufficient space to permit the passage of the knitted web. One lug on each bed is common; but with only two lugs the rotations of the cam-cylinder would move the bed s when the cylinder was reversed.

I claim—

1. The pivoted cams adapted both to elevate and draw down the needles, in combina-

tion with springs to hold the cams up, and with rests above and below the cams to support their free ends, substantially as and for the purpose described.

2. Two pivoted cams and their springs, adapted to operate substantially as described, in combination with pivoted needle-lifters, to elevate the butts of the needles above the pivots of the cams, substantially as described.

3. As a new article of manufacture, a knitting-machine needle provided with a tail-piece and a projecting portion, 2, as and for the purpose described.

4. The combination, with the cam-cylinder, of needles provided with connected tail-pieces, and with butts adapted to project horizontally beyond the portion of the cylinder upon which they rest, to permit the butts to be engaged to lift the needles, and the tail-pieces below the butts retaining the needles in their grooves when elevated, all substantially as described.

5. The dial-annulus and separable cams *b' c'*, pivoted at *d' e'*, and rim *a'*, in combination with the dial-needles, to permit them to be operated to knit or to be drawn out of operative position to hold their loops, all substantially as described.

6. The annulus *y*, provided with an annular rim, *a'*, to prevent the needles from being drawn completely from their beds, and with a central recess to permit access to be had to the butts of the dial-needles, in combination with the dial-bed and its cams *b' c'*, substantially as described.

In testimony whereof I have signed my name to this specification in the presence of two subscribing witnesses.

GEO. A. LEIGHTON.

Witnesses:

G. W. GREGORY,
S. B. KIDDER.