

J. H. RIGGAN.
Plow.

No. 200,478.

Patented Feb. 19, 1878.

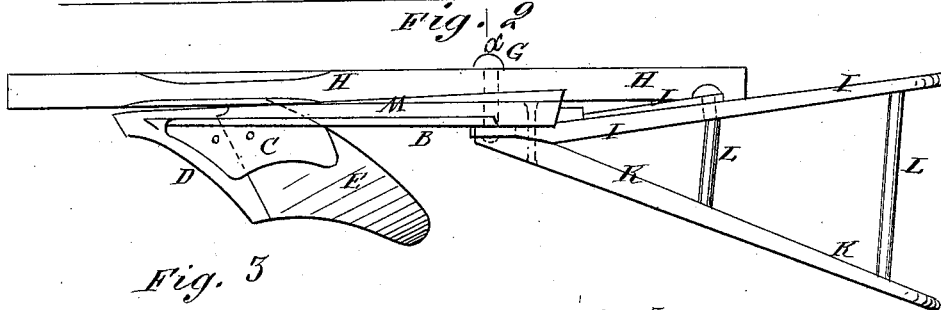
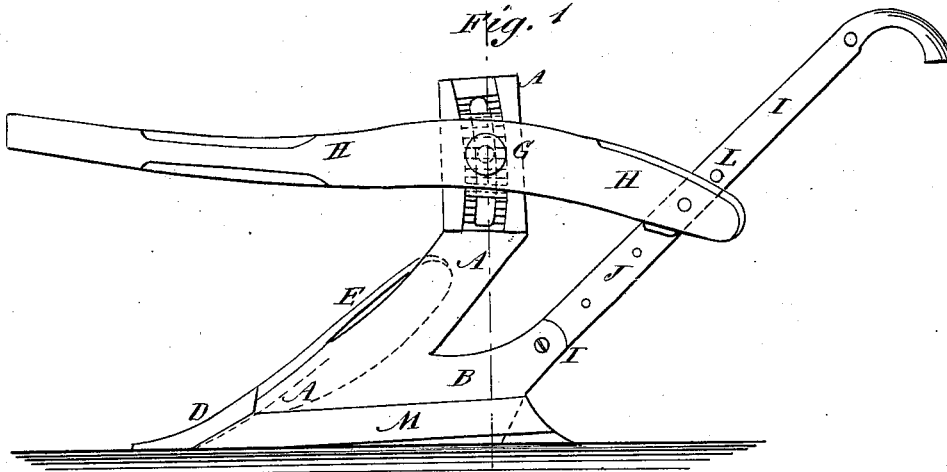

Fig. 5

Fig. 5

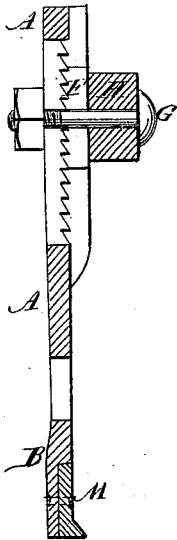

Fig. 4

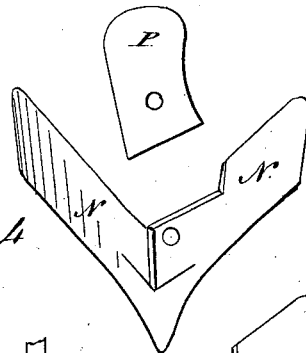
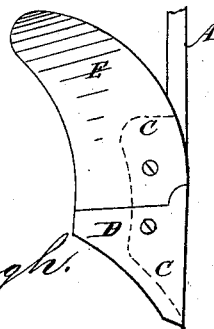

Fig. 6

Fig. 7



WITNESSES:

C. Neveu
J. H. Scarborough.

INVENTOR:

J. H. Riggan.
BY *M. M. M.*

ATTORNEYS.

UNITED STATES PATENT OFFICE.

JONATHAN H. RIGGAN, OF FORESTVILLE, NORTH CAROLINA.

IMPROVEMENT IN PLOWS.

Specification forming part of Letters Patent No. **200,478**, dated February 19, 1878; application filed October 6, 1877.

To all whom it may concern:

Be it known that I, JONATHAN HALL RIGGAN, of Forestville, in the county of Wake and State of North Carolina, have invented a new and useful Improvement in Plows, of which the following is a specification:

Figure 1 is a side view of my improved plow. Fig. 2 is a bottom view of the same. Fig. 3 is a vertical cross-section of the same, taken through the line *x x*, Fig. 1. Fig. 4 is a front view of the plow. Fig. 5 is an under-side view of the guard-plate. Fig. 6 is an under-side view of the sweep. Fig. 7 is an under-side view of the half-sweep.

Similar letters of reference indicate corresponding parts.

The object of this invention is to furnish an improved plow which shall be strong, easily adjusted to work deeper or shallower in the ground, and which will enable its various parts to be readily changed to adapt it for the different kinds of plowing required to be done.

The invention consists in the novel construction of a sweep, to adapt it to take the place of an ordinary point, and in the combination of the guard-plate with the standard and the sweep, to prevent the seat for the mold-board from being worn, as hereinafter fully described.

A is the standard, upon the rear side of the lower part of which is formed the land-side B, and upon its side is formed a flange, C, to serve as a seat for the point D and mold-board or wing E.

In the upper part of the standard A is formed a curved groove to receive the block F, and a curved slot to receive the bolt G, that passes through the beam H and the block F. The bottom of the groove in the standard A, at the sides of the slot and the adjacent side of the block F, have teeth formed in them to interlock with each other and prevent the said parts from slipping upon each other when adjusted, and enable the said parts to be readily adjusted to cause the plow to work deeper or

shallower in the ground. The rear end of the beam H is bolted to the land-side handle I, and braced or strengthened by the bar J, bolted to the said handle I, the lower end of which rests against the upper edge of the land-side B, and its upper end has a flange or shoulder formed upon it to rest against the lower side of the beam H, and relieve the strain upon the bolt that secures and pivots the said beam H to the said handle I.

K is the mold-board handle, which is connected with the land-side handle I by the rounds L. The lower ends of the handles I K meet at an angle, and are both bolted to the land-side B. The outer side of the land-side B is rabbeted to receive the plate M, that receives the wear, and is bolted to the said land-side B, so that it can be readily renewed when worn.

The mold-board E and point D may be removed and replaced by larger or smaller ones, according to the kind of plowing required to be done. The point D may also be replaced by the sweep N or the half-sweep O, in which case the mold-board E should be replaced by the small wing or guard plate P, to protect the flange C from wear, which would prevent the mold-board E from fitting firmly when again required for use.

Having thus described my invention, I claim as new and desire to secure by Letters Patent—

1. The sweep N, having wings, and recessed, as shown and described, so that it may be substituted for point D, as set forth.

2. The combination of the guard-plate P with the standard A and the sweep, to prevent the seat for the mold-board from being worn, substantially as herein shown and described.

JONATHAN HALL RIGGAN.

Witnesses:

C. F. REID,

J. W. BALLANCE, Jr.