

T. M. CHAPMAN.  
Stave-Jointer.

No. 200,507.

Patented Feb. 19, 1878.

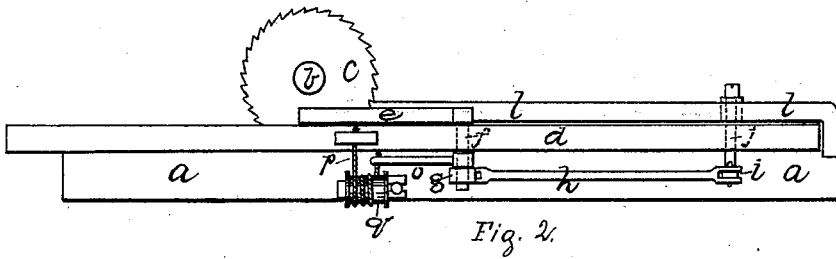

Fig. 2.

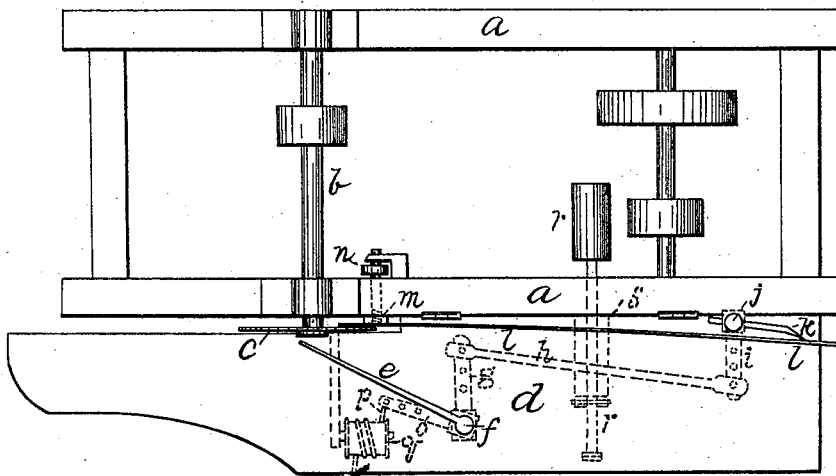

Fig. 7.

WITNESS

*Wm. F. Simmons M.D.*  
*John R. Mason*

INVENTOR

*Thomas M. Chapman*  
*by Geo. Franklin Sawyer Atty*

# UNITED STATES PATENT OFFICE.

THOMAS M. CHAPMAN, OF OLD TOWN, MAINE.

## IMPROVEMENT IN STAVE-JOINTERS.

Specification forming part of Letters Patent No. **200,507**, dated February 19, 1878; application filed January 9, 1878.

*To all whom it may concern:*

Be it known that I, THOMAS M. CHAPMAN, of Old Town, in the county of Penobscot and State of Maine, have invented certain new and useful Improvements in Stave-Jointers; and I do hereby declare that the following is a full, clear, and exact description thereof, that will enable others skilled in the art to which it appertains to make and use the same, reference being had to the accompanying drawings, forming a part of this specification, in which—

Figure 1 is a plan, and Fig. 2 is an edge view of tilting table.

Same letters show like parts.

My invention consists of an improved machine for jointing staves, so arranged as to automatically graduate the bilge and list for varying widths, and capable of adjustment for staves of different patterns.

My invention will be readily understood by reference to the accompanying drawings, in which—

*a* shows a suitable frame, provided with the ordinary pulleys, shafts, &c. At *b* is the saw-arbor, *c* showing the saw.

To the side of the frame is hinged the stave-table *d*, upon which is a lever, *e*, attached to a short upright shaft, *f*, passing down through the table, and turning with the movement of the lever. To the lower end of this shaft is secured an arm, *g*; connected by a rod, *h*, to a second arm, *i*, upon the lower end of a second upright shaft, *j*, passing up through the table, and having a lever, *k*, at its upper extremity. This lever acts against a spring-guide, *l*, attached at one end to the frame *a*.

It will be seen that when a stave is fed to the saw it passes between it and the lever *e*, which is forced outward more or less, in proportion to the width of the stave. This lever communicates the motion, through the mechanism already described, to the lever *k*, which, in turn, throws the guide *l* toward the outer edge of the table, bending it more or less, and thus graduating the curve upon which the stave moves toward the saw, and consequently the bilge or swell of its sides.

The arms *g i* and the lever *k* may all be made adjustable as to length, enabling the shape of the stave to be varied, as required,

for different kinds of barrels, and the guide *l* is adjustably attached to the frame *a* by means of a screw, *m*, and nut *n*, by which its distance from the saw may be regulated at will.

These devices graduate the bilge of the stave in proportion to its width, and they may be used either with or without the mechanism for automatically regulating the list or bevel, which I will now describe.

To the shaft *f*, before mentioned, beneath the table *d*, is rigidly attached a second arm, *o*, to the end of which is fastened a cord or chain, *p*, passing down and one or more times around a pulley, *q*, and returning to the table, to which it is secured, as shown. As the lever *e* is forced out by the passage of the stave, the arm *o* also moves toward the loose pulley *q*. This has the effect of winding the cord or chain a part of the way round the pulley, shortening it and drawing down the edge of the table *f*, thus inclining the stave at an angle to the saw, the amount of inclination, and consequently the amount of list, being directly proportioned to its width.

The amount of list for staves of different length or shape may be regulated by varying the length of the cord *p* or arm *o*.

When not in use, the table *d* is kept horizontal, or nearly so, by a weighted lever, *r*, attached to the frame *a* at *s*, and pressing up against the table *d*, as shown.

What I claim as my invention, and desire to secure by Letters Patent, is—

1. In a stave-jointer, the combination of the table *d* and spring-guide *l* with the levers *e* and *k* and connecting mechanism, substantially as described, whereby the bilge of the stave is automatically regulated, substantially as specified and shown.

2. In a stave-jointer, the hinged table *d*, lever *e*, and arm *o*, in combination with the cord or chain *p* and pulley *q*, whereby the bevel or list of the stave is automatically regulated, substantially as and for the purposes set forth.

In testimony that I claim the foregoing I have hereunto set my hand this 3d day of January, 1878.

THOMAS M. CHAPMAN.

Witnesses:

C. A. BAILEY,  
FOSTER WOOD.