

S. HEVENER.
Harvester.

No. 200,532.

Patented Feb. 19, 1878.

Fig. 1.

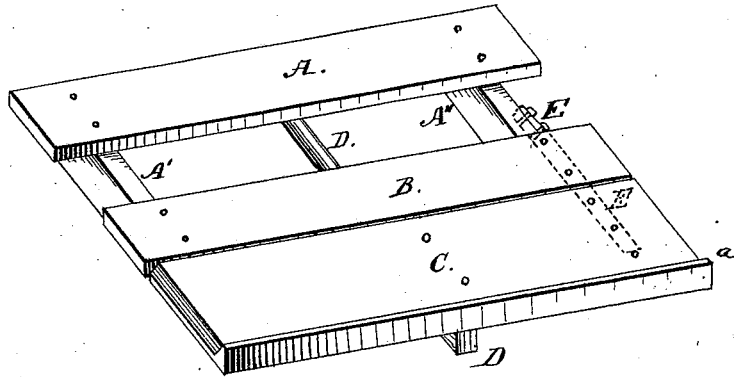
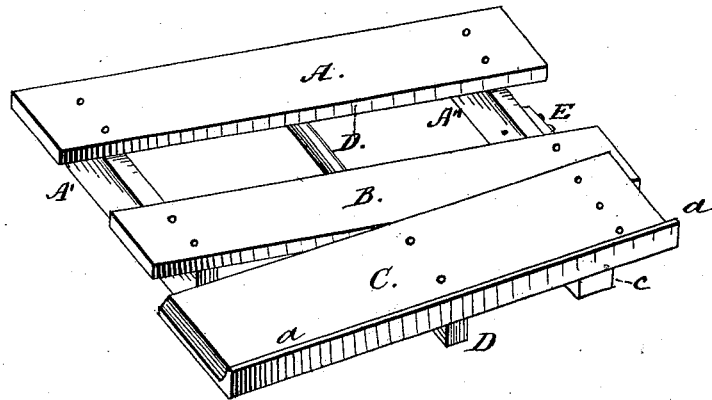

Fig. 2.



Witnesses:

*W. C. Hoigley
H. Hastings*

Inventor:

Samuel Hevener

UNITED STATES PATENT OFFICE.

SAMUEL HEVENER, OF BLAIRSTOWN, IOWA.

IMPROVEMENT IN HARVESTERS.

Specification forming part of Letters Patent No. **200,532**, dated February 19, 1878; application filed August 20, 1875.

To all whom it may concern:

Be it known that I, SAMUEL HEVENER, of Blairstown, in the county of Benton and State of Iowa, have invented a certain new and useful Improvement in Hand-Binders for Harvesters; and I do hereby declare that the following is a full and clear description of my invention, which will enable others skilled in the art to which it pertains to make and use the same, reference being had to the accompanying drawings, which form a part of this specification, and in which the two figures represent the tilting-board which constitutes my invention in two different positions.

My invention relates to the tilting-board or the device for depositing the sheaves on the ground, which forms a part of harvesters in which the binding of the sheaves is done by hand; and it consists in the construction and arrangement of this board, as hereinafter more fully set forth.

A A' A'' is the upper part of the frame of a harvesting-machine, to which the binders' table (represented by B) is secured. D is a rock-shaft, hung in bearings under the frame-piece A and table B, so as to oscillate freely. This shaft also serves to divide the open space between tables A and B into two separate parts or compartments, one for each binder.

E is an arm or bracket, bolted onto the side of beam A'', and projecting laterally, so as to reach in under the tilting-board C, as shown in dotted lines in Fig. 1. Board C is bolted onto the projecting square part of rock-shaft D, and has a weight, *c*, affixed to its forward end back of the bracket E, which causes it to rest on this bracket parallel to the table B, as shown in Fig. 1.

a is a flange running along the outer edge of board C, to prevent the sheaves from dropping off sidewise.

The sheaves are placed by the binders on the board C, on both sides of the rock-shaft D, and when a sufficient quantity has been accumulated to make a shock the board is tipped by one of the binders pressing down on the rear part of it, which tips the board over rearwise, and causes the sheaves deposited upon it to roll off. When empty the weight *c* will cause it to assume automatically its normal position parallel to the table B.

By this construction and combination of the tilting-board with the binders' table—viz., placing said board or receiver the whole length of the binders' table or platform, and causing it to tilt upon an axis transverse to the movement of the machine—it is easily tilted or tipped whenever desired, without the use of levers or similar contrivances, and will replace itself automatically in its horizontal position after the load has been dropped.

Having thus described my invention, I claim and desire to secure by Letters Patent of the United States—

In combination with the frame A A' A'' and binders' table or platform B, having the projecting arm or bracket E, the rock-shaft D and tilting-board or receiver C, placed the whole length of the table or platform B, and oscillating upon an axis transverse to the movement of the machine, substantially as and for the purpose herein shown and specified.

SAMUEL HEVENER.

Witnesses:

H. C. HIGLEY,
H. HARTUNG.