

E. HOWARD.  
Loom.

No. 200,536.  
Fig. 2.

Patented Feb. 19, 1878.  
Fig. 1.

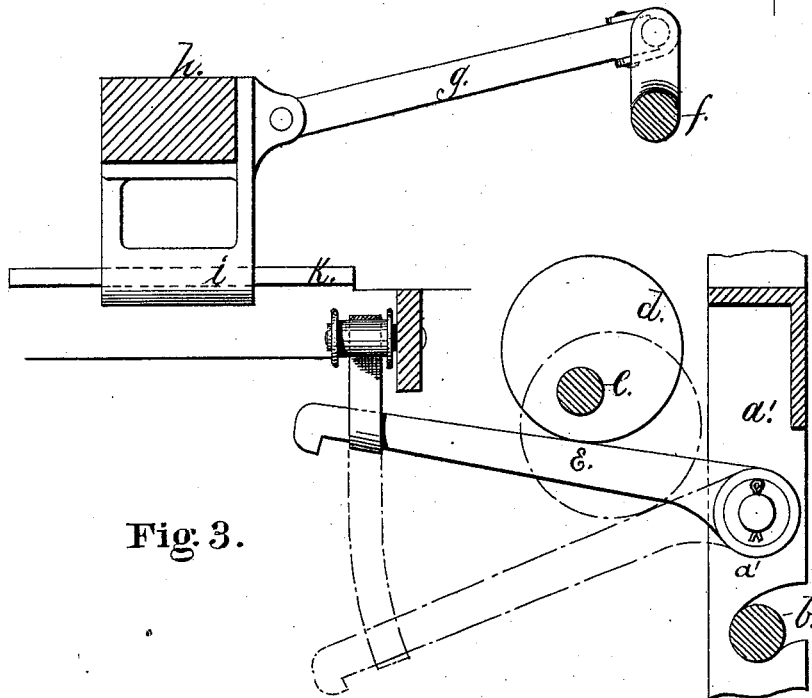
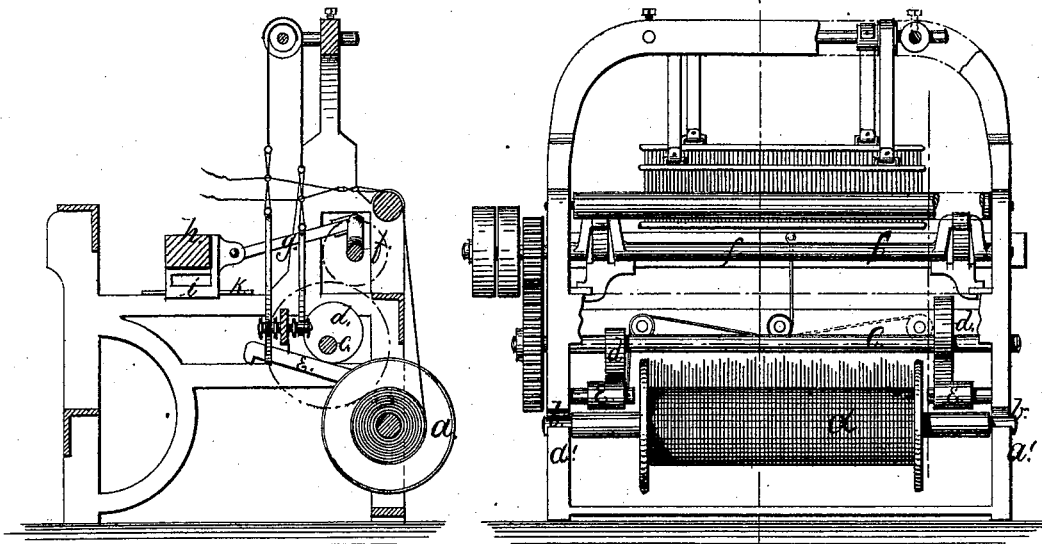

Fig. 3.

WITNESSES.

*P. P. Langworthy*  
*W. A. Coggeshall*

INVENTOR.

*Ephraim Howard*  
*by Joseph A. Miller*  
*Attorney*

# UNITED STATES PATENT OFFICE.

EPHRAIM HOWARD, OF PROVIDENCE, RHODE ISLAND.

## IMPROVEMENT IN LOOMS.

Specification forming part of Letters Patent No. **200,536**, dated February 19, 1878; application filed September 1, 1877.

*To all whom it may concern:*

Be it known that I, EPHRAIM HOWARD, of the city and county of Providence, State of Rhode Island, have invented certain new and useful Improvements in Looms; and I hereby declare that the following is a full, clear, and exact description of the same, reference being had to the accompanying drawings, forming part of this specification.

Figure 1 is an elevation, showing the improvements and giving a general view of the loom. Fig. 2 is a vertical section through the center of the loom, showing the relative positions of the various parts. Fig. 3 is an enlarged section, showing the bearing for the yarn-beam, the cam-shaft and levers, the crank-shaft, and the ways or slides for the lay.

The object of this invention is to so arrange and construct a loom that for the same quality of work it shall occupy less floor-space than looms as heretofore constructed.

The invention consists in the combination, with the yarn-beam, of the harness-actuating levers and cams for operating said levers, the levers and cams being located opposite the ends of the yarn-beam, whereby the latter is brought in close proximity to the actuating parts of the loom, and space economized by such an arrangement of parts.

In the drawings, *a* represents the yarn-beam, the journals of which are supported in bearings *b b* on the side frames *a' a'*. The cam-shaft *c* is located higher in the frame than the yarn-beam *a*, and in close proximity thereto.

In order that the cams *d* may be allowed sufficient space to operate freely in actuating the harness-levers *E*, the cams are secured to the shaft *c* at points outside of the yarn-beam, so that the cams may extend below the periphery of the heads of the yarn-beam.

Levers *E E* are pivoted to studs attached to the side frames *a'* at points opposite the ends of the yarn-beams, said levers being located in the same vertical line as the cams *d*, that they may be actuated thereby.

By locating the cams and levers at either end of the cam-shaft, in the manner above described, it enables the yarn-beam to be moved

a considerable distance beneath the loom-frame, and thus economize much space heretofore occupied by the yarn-beams of looms as ordinarily constructed.

By this arrangement the floor-space occupied by a loom is much less than by the old arrangement, the frame is much narrower, cheaper, and stronger, and all parts of the loom are more closely and compactly placed, while the cams and levers are more accessible.

*f* represents a double crank-shaft; *g*, the connecting-rods, connecting the cranks on the shaft *f* with the lay *h*. *i* is a cross-head, arranged to slide on the way or guide *k*. The rotation of the shaft *f* imparts reciprocating motion to the lay, which, sliding on the ways or slides *k*, is made to move in a horizontal plane.

The motions of the lay are more easy, with less friction and noise, than in the older method, where cams are used, while the friction on the warp is also reduced, as the lay slides horizontally in fixed ways or slides.

The whole construction of the loom is simplified and cheapened, the power used to run the loom reduced, and the space occupied reduced, so that more looms may be operated in a mill than was possible heretofore.

Instead of placing the cams *d* and levers *E* on each end of the cam-shaft, they may be both placed on the same end, if preferred, and the slides or ways *k* may be round, V-shaped, or of any cross-section desired.

Having thus described my invention, I claim as new and desire to secure by Letters Patent—

The following combination of parts within a loom-frame, to wit: a cam-shaft having cams secured thereto at opposite ends thereof, harness-levers pivoted to studs attached to the side frames of the loom, and a yarn-beam located between the opposite sets of cams and harness-levers, all arranged substantially as and for the purpose set forth.

EPHRAIM HOWARD.

Witnesses:

JOSEPH A. MILLER,  
AMOS A. WHITE.