

A. W. HUMPHRY.
Feed-Steamer.

No. 200,537.

Patented Feb. 19, 1878.

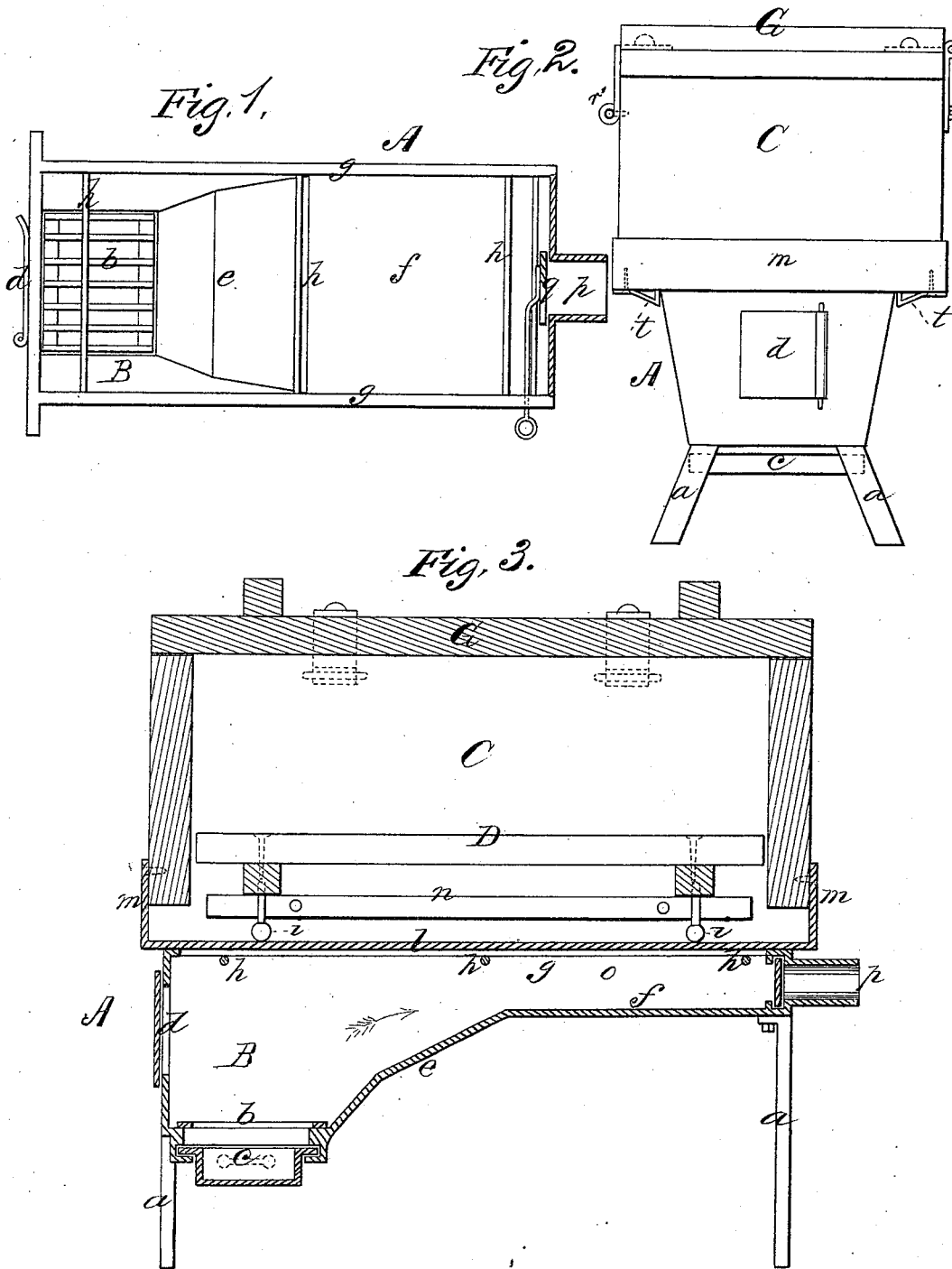

WITNESSES
Villette Anderson.
J. J. Masi

INVENTOR
A. W. Humphrey
By E. W. Anderson
ATTORNEY

UNITED STATES PATENT OFFICE.

ALEXANDER W. HUMPHRY, OF HIRAMSBURG, OHIO.

IMPROVEMENT IN FEED-STEAMERS.

Specification forming part of Letters Patent No. **200,537**, dated February 19, 1878; application filed December 29, 1877.

To all whom it may concern:

Be it known that I, ALEXANDER W. HUMPHRY, of Hiramburg, in the county of Noble and State of Ohio, have invented a new and valuable Improvement in Feed-Steaming; and I do hereby declare that the following is a full, clear, and exact description of the construction and operation of the same, reference being had to the annexed drawings, making a part of this specification, and to the letters and figures of reference marked thereon.

Figure 1 is a top view of the furnace. Fig. 2 is a view of the steamer, and Fig. 3 of the drawings is a representation of a longitudinal vertical section of my invention.

This invention has for its object the improvement of feed-steamers.

The invention consists in a feed steamer or boiler provided with wooden walls, and having short end walls and a metallic bottom, the latter being carried upon the exterior of said end walls, and bounding the end recesses of the chamber under said end walls, as more fully hereinafter shown and described.

In the annexed drawings, the letter A designates a metallic furnace supported upon suitable legs *a*, and open at its top. At one end it is provided with a deep pocket, B, having near its bottom a grate, *b*, below which is an ash-pan, *c*, and provided with a door, *d*, by means of which fuel is introduced into the furnace.

The pocket B is the fire-box of my improved apparatus, and its rear wall slopes upward and backward, as shown at *e*, until it merges into the rear horizontal portion *f* of the furnace-bottom. Above this portion *f* the furnace is quite shallow, and its side walls *g* are braced by transverse metallic stay-rods *h*.

C represents a steaming-box of greater length and width than the furnace, so that, when set upon the upper edge of the same, it will overlap at its sides and ends. This box, as to its sides and ends, is made of wood; but its bottom, *l*, is of metal, preferably sheet-iron, rigidly but removably secured thereto in any suitable manner, with its ends extended up the ends of the box and rigidly secured thereto, as shown at *m*. Inside of the box, near its bottom, longitudinal cleats or ledges

n are secured, upon which a grating, D, rests. This grating is preferably of wood, and has a number of supports, *i*, upon its under side, which bear against the bottom of the steaming-box when the said grating is in place.

As shown in Fig. 3, the bottom *l* of the box forms the top of the fire-chamber and the upper wall of a wide, shallow flue, *o*, formed by the sides, bottom, and end of the furnace, leading from the said chamber to the escape-flue *p* at the rear end of the furnace. The bottom of this box is of metal, and is longer and wider than the furnace. Consequently it overlaps the latter and prevents the flames from coming in contact with its wooden sides and ends, which are thus, to all intents and purposes, as serviceable as metal, while much less costly.

The products of combustion, on their way to the escape-flue *p*, come in contact with the metallic bottom of the steamer, and quickly raise the water therein to the boiling-point, thus subjecting the feed on the grating to a vigorous steaming.

The draft in the furnace is regulated by a damper, *q*, at the entrance of the smoke-flue *p* aforesaid.

In practice the steaming-vessel will have a tight (preferably hinged) lid, G, provided with a hasp or other equivalent device, that engages a staple, *r*, upon the said vessel.

The grating is also removable, in order that the bottom of the said vessel may be cleaned out when necessary.

The bottom *l* of the steaming-vessel is provided with stops *t*, between which the side walls of the furnace are snugly received for the purpose of preventing lateral displacement.

I am aware that boilers have been constructed heretofore with wooden walls and metallic bottoms; but in such the walls lie in contact with the bottom, and there is thus a tendency of the wood to become overheated. By the present construction of the boiler with spaces at the bottom of the end walls, a stratum of water is always interposed between the lower ends of the said end walls and the metallic bottom of the boiler or tank, whereby all liability of the ends of said walls

to become overheated and burned out is avoided. This would occur if such spaces were omitted and the walls were at the ends, as well as at the sides, extended down to the metallic bottom.

What I claim as new, and desire to secure by Letters Patent, is—

A feed-steamer consisting of a wooden boiler, C, having the end walls somewhat shorter than the side walls, and a metallic bottom, l, the latter being carried up on the

exterior of said end walls at m, and bounding the recesses under the edges of said end wall, substantially as specified.

In testimony that I claim the above I have hereunto subscribed my name in the presence of two witnesses.

ALEXANDER W. HUMPHRY.

Witnesses:

BASIL MORGAREIDERE,
JOHN HILL.