

C. H. JONES.
Circular-Sawing Machine.

No. 200,542

Patented Feb. 19, 1878.

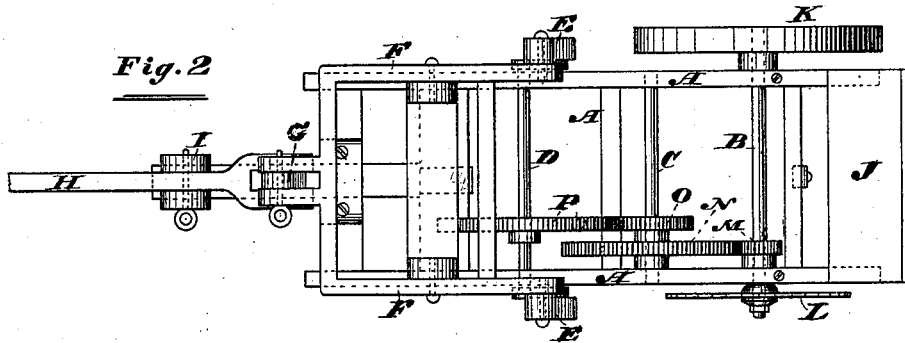
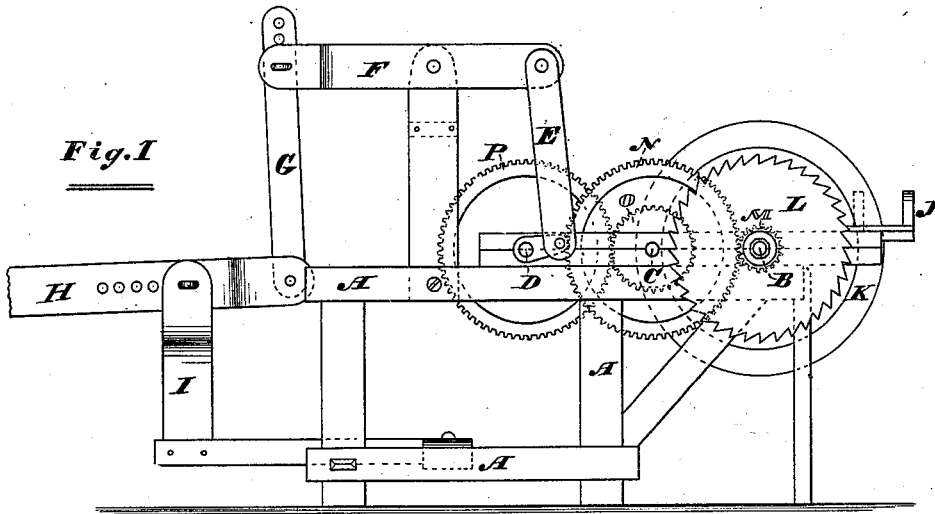

Attest:

W. L. Baker
M. C. Baker

INVENTOR:

Charles H. Jones

By *G. B. Coupland & Co.*

Attorneys.

UNITED STATES PATENT OFFICE.

CHARLES H. JONES, OF WATERTOWN, WISCONSIN, ASSIGNOR OF ONE-HALF HIS RIGHT TO JENKINS JONES, OF CHICAGO, ILLINOIS.

IMPROVEMENT IN CIRCULAR SAWING MACHINES.

Specification forming part of Letters Patent No. 200,542, dated February 19, 1878; application filed September 21, 1877.

To all whom it may concern:

Be it known that I, CHARLES H. JONES, of the town of Watertown, in the county of Jefferson and State of Wisconsin, have made certain new and useful Improvements in Circular Sawing Machines, of which I hereby declare the following to be a full, clear, and exact description, which will enable others skilled in the art to which my invention appertains to make and use the same, reference being had to the accompanying drawings, forming a part of this specification, in which—

Figure 1 is a side elevation of my improved sawing-machine; Fig. 2, a view of the same looking from above.

The object of my invention is the improvement and construction of certain operative mechanism for sawing wood, more especially a machine for sawing fire-wood, and is operated by hand-power.

The nature of my invention consists of a suitable frame-work of wood, or wood and iron, upon which is placed the operating machinery, which I will now proceed to explain in detail.

In the drawing, A represents the frame-work; B, driving-shaft, upon which is placed a circular saw, a pinion, and the fly-wheel; C, counter-shaft, upon which is placed a large gear-wheel and one of a smaller size; D, crank-shaft, upon which is placed one large gear-wheel, which engages with the lesser wheel on shaft C. The larger gear-wheel on the shaft C engages with the pinion on the shaft B. By this arrangement of shafts and gear-wheels the motion is transmitted from the crank-shaft to the saw.

The shaft D is supplied with two single cranks, one at each end of the shaft. To each of the cranks is attached the pitman E, which forms the connection with the working-beam F, there being two pitmen and two working-beams located on each side of the machine. The working-beams F have a reciprocating

motion on a central axis, and form the connection between the pitmen and the operating-levers. G represents a vertical connecting rod or lever, having an adjustable center, the upper end being attached to a cross-piece, which connects the working-beams. H represents the hand or operating lever, one end of which is connected to the lever G, and is likewise provided with adjustable centers, as shown in Fig. 1. This lever has an up-and-down motion similar to that of a pump-handle. I, upright which forms the support and fulcrum for the lever H, said upright being attached at the lower end to a horizontal bar, which is made to slide back and forth, so as to correspond with the centers in the lever H; J, sliding feed-table; K, fly-wheel on shaft B; L, circular saw on the shaft B; M, the pinion on shaft B; N, large gear-wheel on shaft C; O, small gear-wheel on the shaft C; P, the gear-wheel on the crank-shaft D.

I do not strictly confine myself to a system of constructing my machine with double beams or pitmen, but may find it advantageous to make a more direct connection by having a double crank in the center of the crank-shaft, and but one pitman and working-beam placed in the center of the frame, instead of at each side.

Having thus described my invention, what I claim as new, and desire to secure by Letters Patent, is—

In a machine for sawing wood, the combination of the operating-lever H, the connecting-rod G, with the working-beams F and the pitmen E, in connection with the shafts B C D and the gear-wheels N O P, and the pinion M and the operating mechanism, substantially as described.

CHARLES H. JONES.

Witnesses:

W. HENRY BURNS,
S. N. DUNNING.