

H. OWEN.
Try Square.

No. 200,628.

Patented Feb. 26, 1878.

Fig. 1.

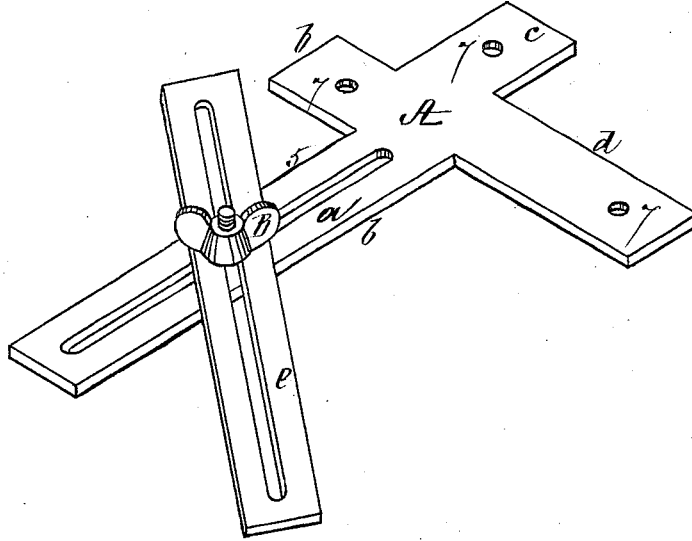

Fig. 3.

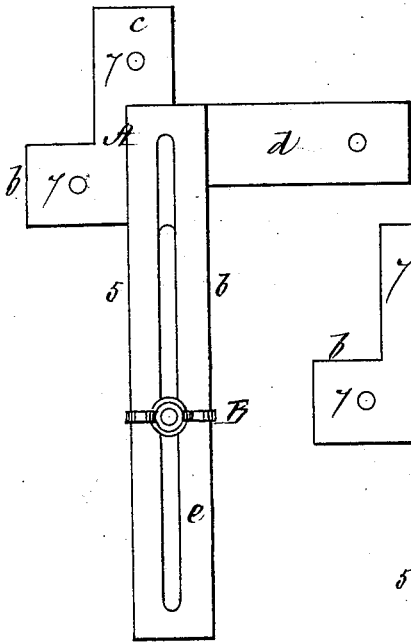
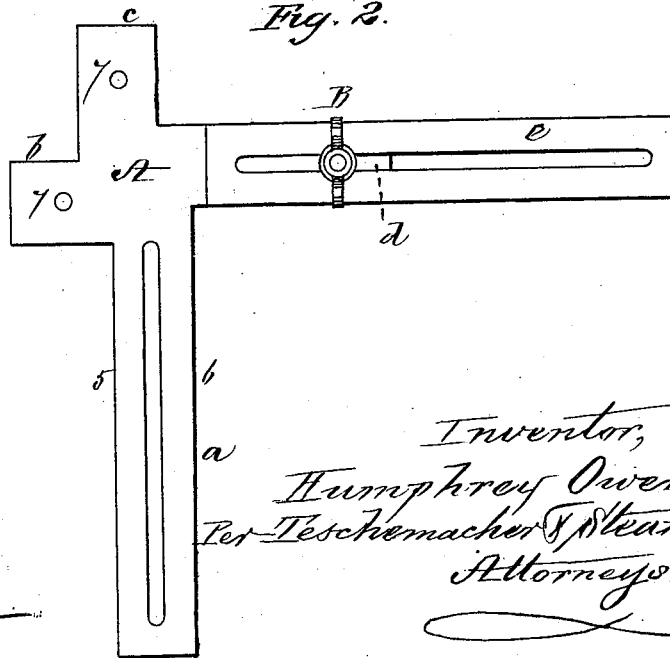

Fig. 2.



Witnesses,
W. J. Cambridge
O. Rice

Inventor,
Humphrey Owen
Per Teschemacher & Stearns
Attorneys.

UNITED STATES PATENT OFFICE.

HUMPHREY OWEN, OF QUINCY, MASSACHUSETTS.

IMPROVEMENT IN TRY-SQUARES.

Specification forming part of Letters Patent No. **200,628**, dated February 26, 1878; application filed January 19, 1878.

To all whom it may concern:

Be it known that I, HUMPHREY OWEN, of Quincy, in the county of Norfolk and State of Massachusetts, have invented an Improved Try-Square, for the use of stone-cutters and others, of which the following is a full, clear, and exact description, reference being had to the accompanying drawings, making part of this specification, in which—

Figure 1 is a perspective view of my improved square with a bevel applied thereto. Fig. 2 is a plan of the same, the position of the parts being changed. Fig. 3 is a plan representing one of the arms of the square lengthened by the application thereto of the slotted bevel-arm.

This invention consists in a try-square having a series of three or more projecting arms, each of a different length, whereby a series of two or more independent squares of different sizes are formed in one implement, which is thus particularly adapted for use in cutting stone, where it becomes necessary to try the accuracy of moldings of different forms, depths, and sizes during the operation of cutting, and which has heretofore required the employment of a number of separate squares of different sizes.

My invention also consists in the combination of a slotted bevel-arm with a try-square, constructed as above described.

To enable others skilled in the art to understand and use my invention, I will proceed to describe the manner in which I have carried it out.

In the said drawings, A represents the try-square, composed of a long slotted arm, *a*, and three shorter arms, *b c d*, of different lengths, projecting from one end of the same, the short arm *b* extending out from and at right angles to one side, 5, of the slotted arm *a*, and the long arm *d* extending out from and at right angles to the opposite side 6 of the slotted arm *a*, while the arm *c* is of a length somewhere between the lengths of the arms *b d*, and lies in a position intermediate between them, and nearly in line with the slotted arm *a*, a series of squares of different lengths be-

ing thus formed in one and the same piece, these squares being used for testing the accuracy of different surfaces of stone in the formation of moldings, which cannot be done with a single square of the ordinary construction, and which testing has heretofore required the employment of a number of squares of different sizes.

To the slotted arm *a* is secured, by means of a clamping-screw, B, a slotted arm, *e*, which can be adjusted and held in various positions with respect to the slotted arm *a*, thereby forming a bevel, for transferring bevel-angles from the plan of the work to the surface of the stone to be cut; but this bevel-arm *e* may be dispensed with, if desired.

Should either of the arms *b c d* require to be elongated, it is simply necessary to detach the bevel-arm *e* from the slotted arm *a* and apply it to the arm to be lengthened, Fig. 3, and secure it thereto by means of the clamping-screw B, which passes through an aperture, 7, near the outer end of the arm.

It will be seen that a try-square constructed in accordance with my invention obviates the necessity of using a number of separate and independent implements, as heretofore, which are, moreover, not always at hand, are expensive, and occupy considerable space.

What I claim as my invention, and desire to secure by Letters Patent, is—

1. The within-described try-square, provided with three or more arms, each of a different length, forming a series of two or more independent squares of different sizes in a single implement, substantially as and for the purpose set forth.

2. The combination of the slotted bevel-arm *e* with a try-square having arms *a b c d*, of different lengths, substantially as and for the purpose specified.

Witness my hand this 8th day of January, A. D. 1878.

HUMPHREY OWEN.

In presence of—
N. W. STEARNS,
W. J. CAMBRIDGE.