

W. F. CONDON. Self-Extinguishing Stove.

No. 200,697.

Patented Feb. 26, 1878.

Fig. 1.

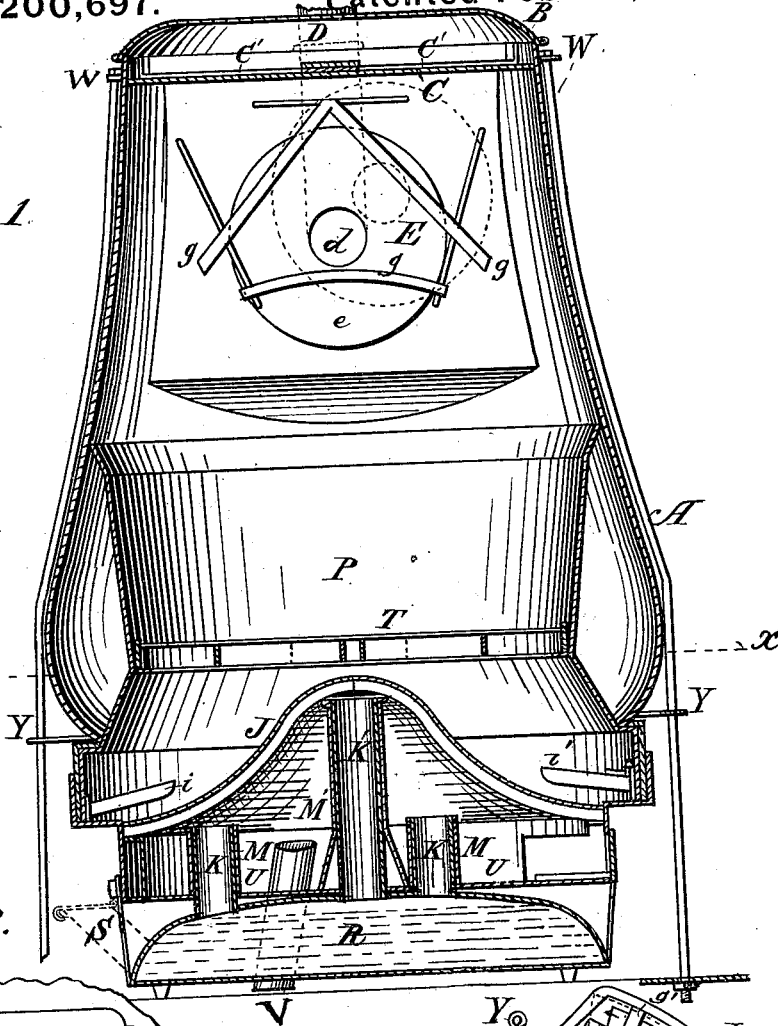

Fig. 3.

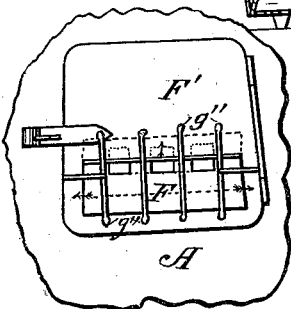
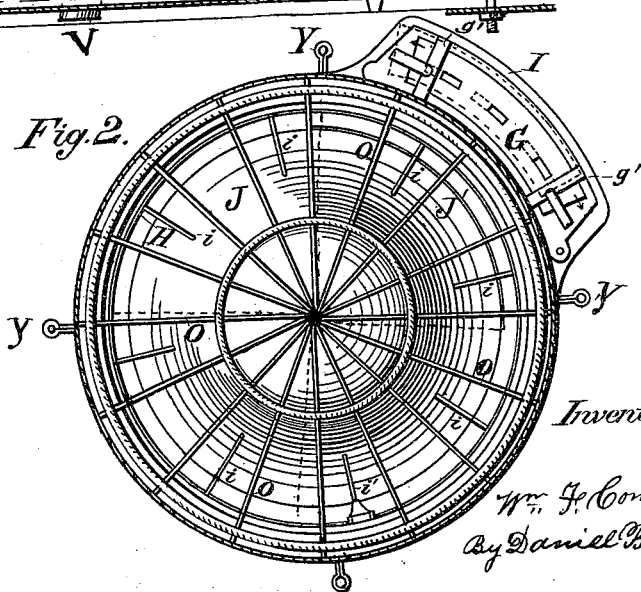

Fig. 2.



Attest:
H. W. Schott.
 J. C. Condon

Inventor:
W. F. Condon
 By *Daniel Breed*
 Atty.

W. F. CONDON.
Self-Extinguishing Stove.

No. 200,697.

Patented Feb. 26, 1878.

Fig. 6.

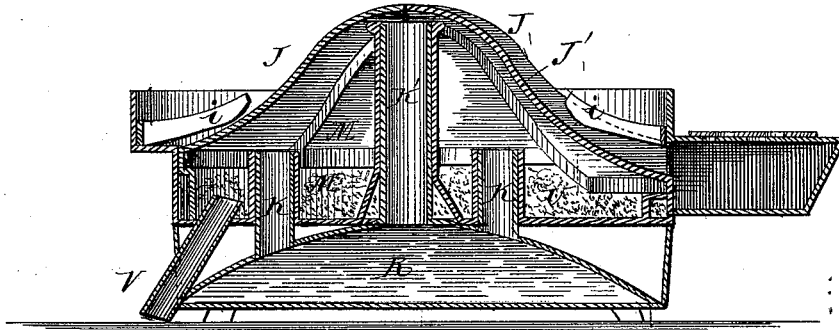
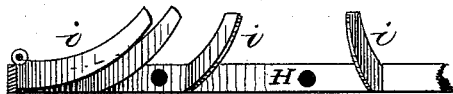

Fig. 7.



Witnesses:

And G. Dutrich
Wm. H. Bates.

Inventor:

Wm. F. Condon

Per

Daniel Breed Attorney

W. F. CONDON.
Self-Extinguishing Stove.

No. 200,697.

Patented Feb. 26, 1878.

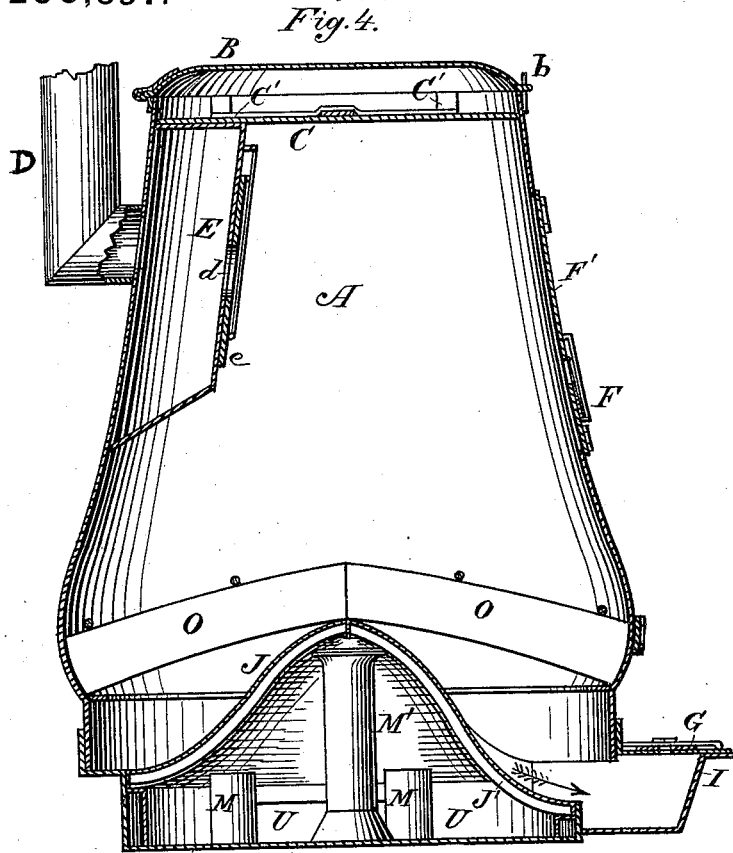

Fig. 5.

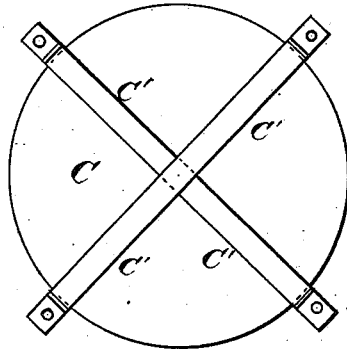

Fig. 9.

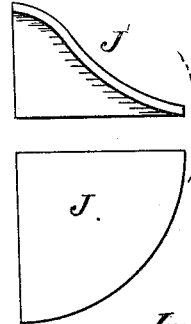

Fig. 10.

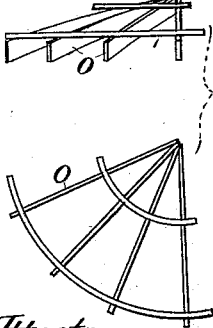
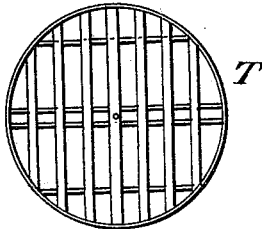

Fig. 6.



Inventor:

Wm. F. Condon
By Daniel Breed
Atty.

Attest:
H. H. Schott
B. M. Briggs.

UNITED STATES PATENT OFFICE.

WILLIAM F. CONDON, OF ZILWAUKIE, MICHIGAN, ASSIGNOR OF ONE-HALF HIS RIGHT TO ERNST WETZEL, WILLIAM E. GARDNER, DAVID CREASER, AND E. J. CLARK, OF SAME PLACE.

IMPROVEMENT IN SELF-EXTINGUISHING STOVES.

Specification forming part of Letters Patent No. 200,697, dated February 26, 1878; application filed May 24, 1877.

To all whom it may concern:

Be it known that I, WILLIAM F. CONDON, of Zilwaukie, in the county of Saginaw and State of Michigan, have invented certain new and useful Improvements in Self-Extinguishing Stoves; and I do hereby declare that the following is a full, clear, and exact description thereof, which will enable others skilled in the art to which it appertains to make and use the same, reference being had to the accompanying drawings, and to the letters of reference marked thereon, which form a part of this specification.

In the accompanying drawings, Figure 1 is a vertical section of my self-extinguishing stove for railroad-cars. Fig. 2 is a horizontal section of the same on the line *x x*, Fig. 1. Fig. 3 represents a detached view of part of the front of the stove, including the front door and its cut-off slide. Fig. 4 is a section showing the wood-grate in place or substituted for the coal-grate, which, with the coal-fire pot, has been removed. Fig. 5 is a detached view of top of the inner cover with its cross-bars. Fig. 6 is a detached top view of the coal-grate. Fig. 7 represents a detached view of part of the ash-rake, showing the form of the scrapers attached to a ring of metal forming the head of the rake. Fig. 8 is a vertical section of the lower part of the stove, showing the relation of the salt-chamber, water-tank, and other parts. Fig. 9 is a detached view of a quadrantal section or part of the arch or floor below the grate, the lower part of the figure showing a plan and the upper part an edge view thereof. Fig. 10 is a detached view of a quadrantal section or part of the grate, the lower part of the figure representing a plan and the upper part a perspective view of the same.

My invention consists of a novel construction of stove having a tumbling floor, water-tank, and salt-chamber under the fire, and several self-closing shut-offs, all of which will be fully understood by the following description.

The main cylinder of my stove may be of the ordinary form, as shown at A, Fig. 1, of the accompanying drawings.

Below the coal-fire pot P and grate T is a

conical floor, J, which is cast in four sections, as indicated by four radial dotted lines denoting sections in said floor. These quadrantal sections fit loosely in place, and the top or arch of the floor, or the sections thereof, rest upon the top of the central pipe or tube M, Figs. 1 and 4, which surrounds the pipe K', Fig. 1, hereinafter explained. By this construction the floor J or the sections thereof will tumble when the stove is overturned, and thus allow water from the tank R and salt from the chamber U to be precipitated upon the fire in order to extinguish the same. This floor has one quadrantal section, J', longer than the others, and extending down into the ash-pan I, as seen in Fig. 4. The floor being very high in the center, the ashes falling through the grate T slide downward on the floor, toward the outer edge thereof; and a rake or loosely-fitting ring, H, provided with scrapers *i*, (best shown in Fig. 7,) is arranged to be revolved, and thus the scrapers *i* will bring the ashes round till they fall into the ash-pan I. This rake or ring is usually shaken or revolved by means of a removable handle, to be inserted into a hole in the ring; and one or more of the scrapers upon the ring H may be cast separate from the ring and hinged thereto, as shown at *i'*, so as to be turned or folded up to serve as a handle for revolving the rake, and then turned down again in place like the other scrapers.

In the lower part of the stove is a water-tank, R, Fig. 8, having several pipes, K and K', passing up through pipes M and M' of the salt-chamber, hereinafter to be described. These pipes of the water-tank are intended for discharging water upon the fire when the stove is overturned.

The tank R is to be filled through pipe S, Fig. 1, which may be provided with a glass index to show the height of the water; and the tank should have a faucet for drawing off the water in cold weather to prevent freezing when the fire is extinguished.

Above the water-tank, and yet below the fire, is a salt-chamber, U, extending over the whole area of the lower part of the stove. This chamber has a central pipe, M', loosely surrounding the pipe K of the water-

tank, and also several other pipes, M, which surround the pipe K of the water-tank, thus preventing the water and salt from mixing until both are discharged or thrown upon the fire by overturning the stove.

In Fig. 8 the irregular shading of the salt-chamber U indicates dry salt filling the chamber. Thus this salt remains dry until the stove is overturned, when the salt falls upon the fire, which is at the same time flooded by water from the tank R flowing through the pipes K and K', as above explained.

The bottom of the stove is provided with a pipe, V, extending above the salt-chamber, and left open in order to let off the steam and smoke when the stove is overturned, and the regular smoke-pipe is thus closed by its cut-off, as will be explained.

My stove is provided with a double top or two covers, B and C, Fig. 1. The cover B is hinged to the top of the cylinder A, and when closed may be secured by the usual wire key put into the catch b, Fig. 4. The inner cover C is shown detached in Fig. 5. The ends of the cross-bars C' project beyond the sides of the cylinder A when the cover is in place, and thus form lugs to receive the bolts W, Fig. 1, which pass down through lugs Y and fasten the stove to the floor in the usual manner.

The smoke-pipe, the front door, and the draft at the ash-pan are all provided with self-closing slides or cut-offs, which are held loosely in place by guide-rods or check-wires, so that said slides will move by their own weight when the stove is overturned, and thus close the smoke-pipe, the draft of the front door and of the ash-pan, respectively.

A small chamber, E, is made on the inside of the stove and in front of the smoke-pipe D, Fig. 4, and provided with a round disk or shut-off, e, having a hole, d, which is directly opposite the flue or pipe D when the stove is in the upright position. This shut-off is held loosely by means of guide-rods g, and will move by its own weight to the right or left when the stove falls over, and thus close the smoke-pipe, as indicated in dotted lines, Fig. 1.

The front door is shown at F', Fig. 3, which is a detached view of part of the front of the stove, the main portion of cylinder A being broken away. The self-closing slide F is loosely held in place on the door by means of guide-rods g'', so as to be capable of moving either laterally or upward in case the stove falls over, and thus (sliding by its own weight) close the draft through the door, as indicated

by dotted lines and upward motion in Fig. 3. In like manner the ash-pan I, or the draft therein, has a slide, G, loosely held by guide-rods g', and capable of sliding by its own weight as the stove is overturned, motion of the slide in one direction being indicated in dotted lines.

All the doors of the stove, including those for cleaning, should be fastened by the common keys or wire rings used for such purposes.

In order to use wood, the coal-grate T and fire-pot P are removed and the wood-grate O substituted. This grate is made in four quadrantal sections, as shown at O, Figs. 10 and 4, the radial bars of the same being flat and thin, while the bars of the coal-grate are broader, as seen in Figs. 6 and 7.

Having described my invention, what I claim is—

1. The sectional or tumbling floor J, in combination with a water-tank below the same, substantially in the manner and for the purposes set forth.
2. The steep arched floor J, in combination with the ring H, having scrapers thereon, substantially as set forth.
3. The water-tank R, provided with several pipes, K, in combination with the salt-chamber, having pipes M, substantially as and for the purposes set forth.
4. The shut-off or slide F, in combination with the stove-door, said slide being held loosely in place by means of the guide-rods g'', so that the slide or shut-off will close by means of its own gravity when the stove is overturned.
5. In combination with the smoke-pipe d, the shut-off e, held loosely in place by guide-rods g, so that said slide, moving by its own gravity, will close the flue whenever the stove falls over, no matter in which direction it falls, substantially as set forth.
6. The sliding damper G, in combination with the ash-pan and the draft-openings therein, said slide being held loosely in place by means of guide-rods g', and arranged, as described, so as to close by its own weight when the stove is overturned in any direction, substantially as set forth.

In testimony that I claim the foregoing as my own I affix my signature in presence of two witnesses.

WILLIAM F. CONDON.

Witnesses:

DANIEL BREED,
E. C. WEAVER.