

C. HUNTER.
Reciprocating Steam-Engines.

No. 200,725.

Patented Feb. 26, 1878.

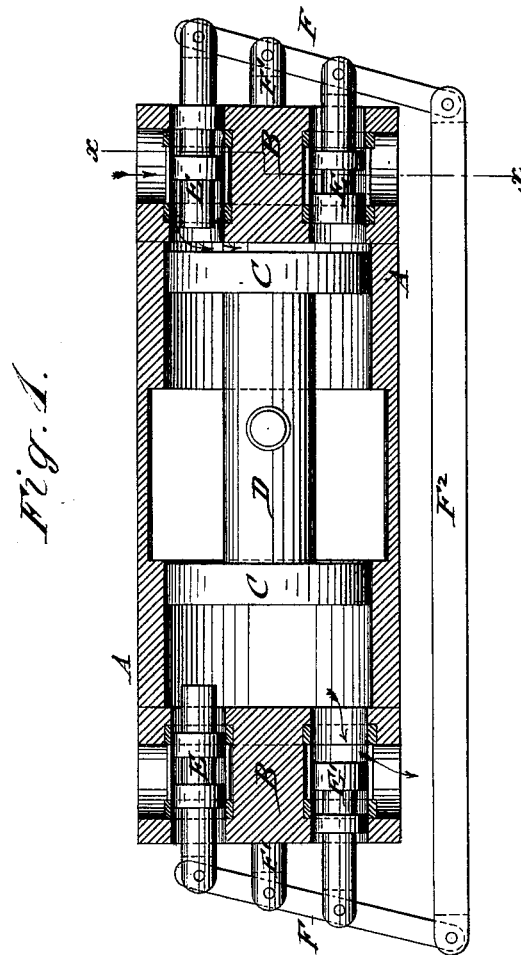
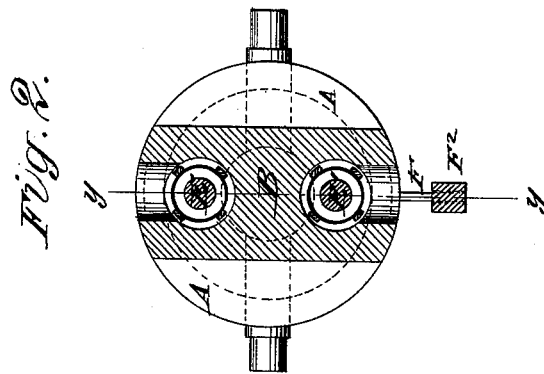

WITNESSES:

H. Rydquist
J. H. Scarborough.

INVENTOR:

C. Hunter.

BY

Mumford

ATTORNEYS.

UNITED STATES PATENT OFFICE.

CYRUS HUNTER, OF STONEWALL, VIRGINIA, ASSIGNOR TO HIMSELF AND JOHN F. HUNTER, OF SAME PLACE.

IMPROVEMENT IN RECIPROCATING STEAM-ENGINES.

Specification forming part of Letters Patent No. **200,725**, dated February 26, 1878; application filed July 30, 1877.

To all whom it may concern:

Be it known that I, CYRUS HUNTER, of Stonewall, in the county of Augusta and State of Virginia, have invented a new and Improved Steam-Engine, of which the following is a specification:

In the accompanying drawing, Figure 1 represents a vertical longitudinal section of my improved steam-engine on line *yy*, Fig. 2; and Fig. 2 is a vertical transverse section of the same on line *xx*, Fig. 1.

Similar letters of reference indicate corresponding parts.

The invention has reference to an improved steam-engine by which a more perfect alignment of pistons and rod is obtained than with the ordinary cylinder, cross-head, and ways, and in which the piston-rod requires no stuffing-box, as it does not pass through a cylinder-head, partition, or abutment, being therefore without leakage or friction from that source.

The valves are put in motion by the pistons, and are coupled together so as to insure the opening and closing of the ports at the right time.

The cylinders can be oiled from the outside, and leakage by the pistons be seen, and any adjustment of the piston-packing can be made without removing any of the parts to get access thereto.

The valves are balanced, and require but little power to be moved.

The effective force of the engine is fully realized, as the cylinders are thoroughly cleared at each throw of the pistons as the steam enters the cylinders, and it has thereby the entire area of the bore of the cylinder to act upon in the forward and backward throw of the pistons.

The invention consists, essentially, of a cylinder with closed heads and broken-out middle part, by which two cylinders are formed, in which two separate pistons with a single connecting-rod and cross-head work. The pistons operate the supply-valves, which are coupled by valve-levers and longitudinal beam to each other and to the exhaust-valves. The valves work in the cylinder-heads parallel to the axis of the cylinders.

In the drawing, A represents the separate cylinders, which are formed by breaking out the middle section of a large cylinder, they being open at the inside, but closed by strong heads B at the outer ends.

The pistons C, one for each cylinder-section, are secured to the end of a heavy connecting piston-rod, D, to which the cross-head is attached centrally between the pistons, the latter being connected to the crank-shaft by a beam with forked end, that straddles the cylinder.

The supply-valves E are operated by the pistons C as the stems or spindles of the valves are extended into the cylinder to the distance to which the valves are to be opened.

The supply ports and valves are arranged at the upper part of the cylinders, the exhaust ports and valves at the lower part of the same, the valves being cylindrical in shape and arranged to move in their seats parallel to the longitudinal axis of the cylinders.

The supply and exhaust valves of each cylinder are coupled together by levers F, which are fulcrumed to fixed center-posts F¹ of the cylinders, and also connected along the bottom of the cylinders by a rod, F², so that the valves of both cylinders work at the same time.

The exhaust-valves have no inwardly-extending stem or spindle, but follow the motion of the supply-valves by their connection with the valve-levers.

The steam-passages are arranged in the head of the cylinders, and enter through slotted cylindrical or sleeve-shaped packing of the valves, which move like pistons in the packing, admitting a free circulation of steam all around the slotted cylinders. No stuffing-box for the piston-rod is required, and the steam supplied at once to the cylinders, owing to the shortness of the entrance-ports.

A main feature of my invention consists in the balancing the movement of the valves, one supply-valve balancing always the corresponding exhaust-valve, as the steam acts in opposite direction on equal areas, and facilitates thereby the easy working of the valves with hardly any friction. The pistons and valves can be conveniently kept in working

order, as all the parts may be readily inspected and reached without difficulty from the outside, furnishing thus an effective engine that works with little loss of power.

Having thus described my invention, I claim as new and desire to secure by Letters Patent—

The combination of cylinders A and connected pistons C with the supply-valves E,

having inwardly-extended stems, fulcrumed valve-levers F, exhaust-valves E', and connecting-rod F², to produce simultaneous movement of the valves and balancing the movement of the same, substantially as specified.

CYRUS HUNTER.

Witnesses:

WM. M. FUNKHOUSER,

H. M. ARGALRIGHT.