

B. MURPHY.  
 Power Mechanism for Hammers.

2 Sheets—Sheet 1.

No. 200,748.

Patented Feb. 26, 1878.

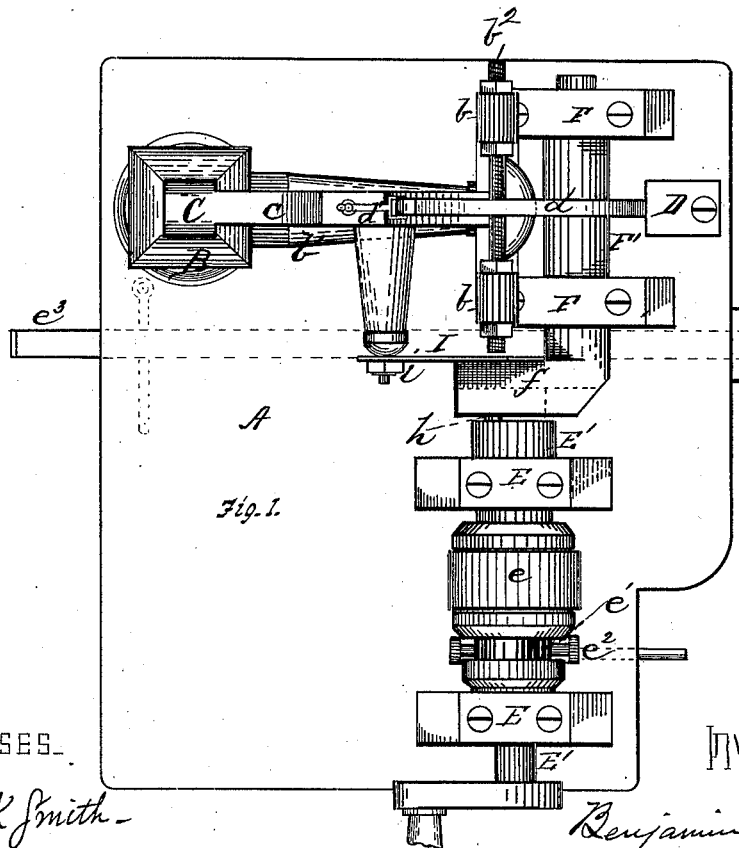

Fig. 1.

WITNESSES.

John K Smith -  
 R. O. Wrenshaw

INVENTOR.

Benjamin Murphy  
 by Bakewell & Beer  
 Atty.

B. MURPHY.  
Power Mechanism for Hammers

No. 200,748.

Patented Feb. 26, 1878.

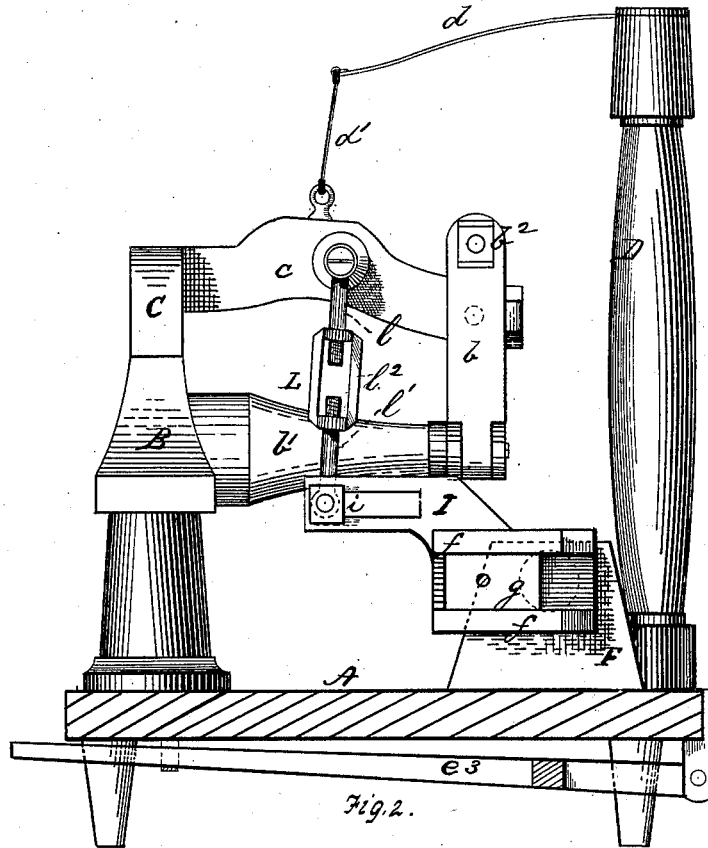

Fig. 2.

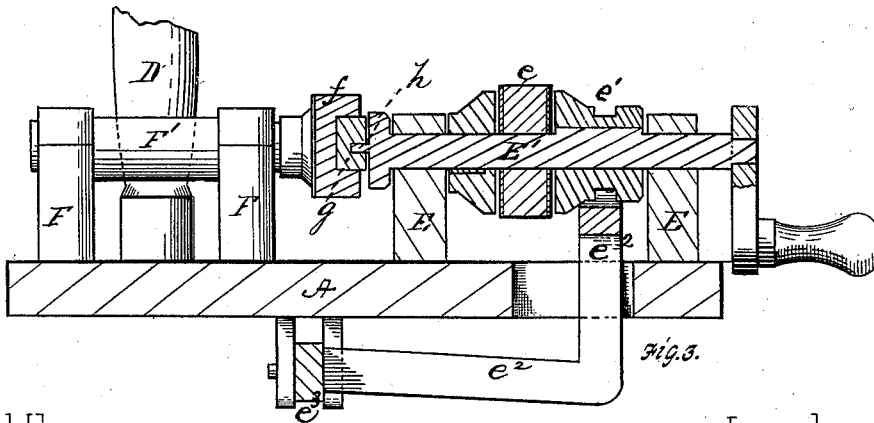

Fig. 3.

Witnesses.

John R. Smith.  
R. C. W. Marshall.

INVENTOR.

Benjamin Murphy  
by Bakewell & Kim  
attys

# UNITED STATES PATENT OFFICE.

BENJAMIN MURPHY, OF ALLEGHENY, PENNSYLVANIA.

## IMPROVEMENT IN POWER MECHANISMS FOR HAMMERS.

Specification forming part of Letters Patent No. 200,748, dated February 26, 1878; application filed December 28, 1877.

*To all whom it may concern:*

Be it known that I, BENJAMIN MURPHY, of Allegheny, in the county of Allegheny and State of Pennsylvania, have invented a new and useful Improvement in Power Mechanisms for Hammers; and I do hereby declare the following to be a full, clear, and exact description thereof, reference being had to the accompanying drawing, forming part of this specification, in which—

Figure 1 is a plan view of devices embodying my invention. Fig. 2 is an elevation of a portion of the devices; and Fig. 3 is an elevation of the power mechanism, partly in section.

Like letters refer to like parts wherever they occur.

My invention relates to mechanism for actuating an "Oliver" or other hammer, and for regulating and controlling the blow thereof; and consists, first, in interposing a shaft, with crank-pin and independently-pivoted slide, between the power-shaft and hammer, whereby a slow rising and quick falling motion is imparted to the hammer, as in hand-striking; secondly, in actuating the hammer from the power-shaft by a slotted arm and link adjustable thereon, whereby the distance through which the hammer is caused to move may be controlled; thirdly, in connecting the hammer and slotted arm of the power-shaft by an adjustable link, whereby the relations of the hammer to the anvil can be regulated at will.

I will now proceed to describe my invention, so that others skilled in the art to which it appertains may apply the same.

Upon a suitable bed, A, is placed an anvil-block, B, and hammer C, the latter pivoted by its helve *c* in bearings *b*, preferably supported on an arm, *b'*, extending from the block B, the bearings being hinged and connected by a cross-bolt, *b''*, adapted, as shown, to be adjusted to compensate for any wear in the hammer-bearings. From a post, D, in rear of the hammer, or from other suitable point, extends a spring-arm, *d*, connected to the hammer-helve by a link, chain, rod, or like means, *d'*, which devices assist the lift of the hammer after its downward stroke. This spring, if made stiff, as it should be, supports the weight of the

hammer in such wise that the hammer will be held up or supported off the anvil whenever the power is detached.

The mechanism thus far described may be that of an ordinary Oliver, similar to what is shown, or may be of any approved construction.

To impart power to such devices I arrange in suitable bearings or housings, E E and F F, two shafts—the one, F', adapted to oscillate being provided on its end with a box, (or guides,) *f*, in which moves a slide, *g*, that engages with a crank-pin secured to the other (or power) shaft, E'.

E' represents a power-shaft fitted with the loose pulley *e* and a sliding clutch, *e'*, the latter connected to shaft E' by a spline, or in other suitable manner, so as to rotate therewith, and operated by the shipping-lever *e''* and treadle *e'''*. On the extremity of shaft E' is a crank-pin, *h*, which engages with the slide *g*, so that the revolution of the power-shaft is converted into a reciprocating motion in the slide, and an oscillatory motion in shaft F'.

Secured to shaft F', or box *f*, thereof is a slotted arm, I, carrying a pin or bolt, *i*, adjustable along the slot, said bolt *i* serving to pivot a link, L, which connects the arm I and hammer-shaft. Accordingly as the pivot-bolt *i* is adjusted along the slotted arm, so as to be nearer to or farther from the shaft F' or center of motion, will the stroke of the hammer be longer or shorter.

The link L is made in two sections, *l l'*, connected by a right-and-left-hand-threaded nut or coupling, *l''*, so that the link can be lengthened or shortened at will, to adjust the hammer with relation to the anvil.

The operation of these devices is as follows: A belt from a suitable driving-shaft being passed around the loose pulley and the clutch *e'* pressed against pulley *e*, the power-shaft E' is rotated, and through its crank *h* reciprocates the slide *g*, imparting an oscillatory motion to slotted arm I, which, through link L, causes the hammer to rise with a slow motion and fall with a quick stroke, as in hand-hammering.

The hammer will move through the greatest space or have the longest stroke when the link

is at the extremity of the slotted arm, and in order to decrease the length of the stroke all that is required is to loosen the nut or pin *i* and move the pin or pivot in along the arm *I*, or nearer the center of motion. If, after lengthening or shortening the stroke by the means specified, or from other cause, it is found that the hammer works too close to the anvil, or does not work as close to the anvil as is desired, the link-coupling *L*<sup>2</sup> may be turned to lengthen or shorten link *L*, and thus regulate the relation of the hammer to the anvil.

While not wishing to limit myself in the construction of the clutch and loose pulley of the power-shaft, I would state that I prefer to employ a friction-clutch rather than a positive clutch, as thereby the machinery is guarded against any injury which might be done by the rebound of the hammer, the jar, &c.; and to render the clutch more effective I usually face either the clutch or loose pulley with leather.

The shaft *F*' may be dispensed with or reduced to a mere pivot for box *f*, if desired.

The advantages of my invention are, that a slow rising and quick falling motion can be imparted to the hammer, as in hand-work, the stroke of the hammer can be adjusted as desired, the devices are simple and effective, and not liable to get out of repair.

Having thus described my invention, what I claim, and desire to secure by Letters Patent, is—

1. The combination, with an Oliver or like hammer, of the power-shaft, provided with a crank-pin, a slide, and independently-pivoted ways, and connecting devices for operating the hammer from the independently-pivoted ways, substantially as specified.

2. The combination, with the hammer, of the power-shaft, provided with a crank-pin, a slide, and its pivoted ways or box, an arm projecting from the box, and a link adjustable on the arm, substantially as and for the purpose specified.

3. The combination, with a hammer of the class specified, of the power-shaft, provided with a crank-pin, a slide, and its pivoted ways, the link-arm, and adjustable link, substantially as and for the purpose specified.

In testimony whereof I, the said BENJAMIN MURPHY, have hereunto set my hand.

BENJAMIN MURPHY.

Witnesses:

F. W. RITTER, Jr.,  
W. BAKEWELL.