

A. F. PFEIFER.  
Transom-Lifter.

No. 200,753.

Patented Feb. 26, 1878.

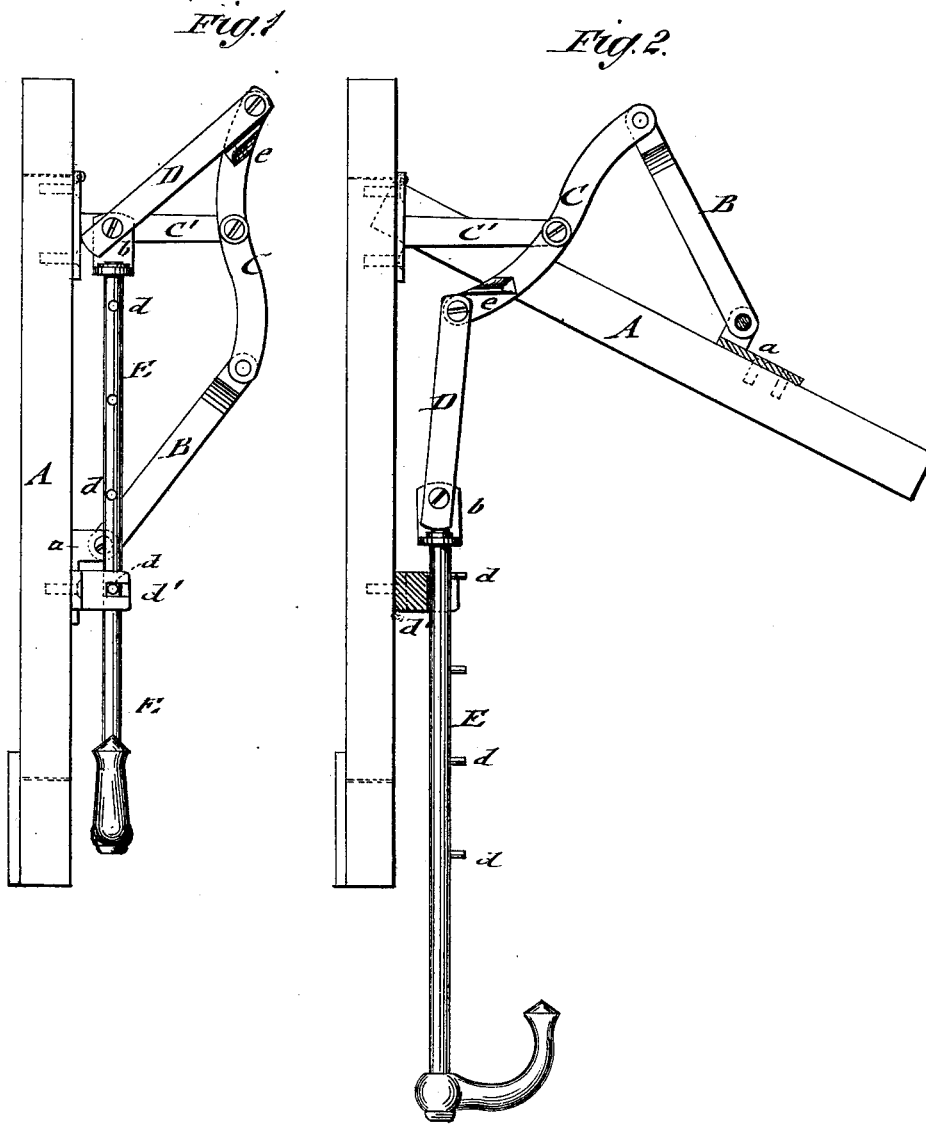

WITNESSES:

*Francis McCordle.*  
*C. Sedgwick*

INVENTOR:

*A. F. Pfeifer*  
BY *Munroe*

ATTORNEYS.

# UNITED STATES PATENT OFFICE.

AUGUST F. PFEIFER, OF NEWARK, NEW JERSEY.

## IMPROVEMENT IN TRANSOM-LIFTERS.

Specification forming part of Letters Patent No. **200,753**, dated February 26, 1878; application filed January 16, 1878.

*To all whom it may concern:*

Be it known that I, AUGUST F. PFEIFER, of Newark, county of Essex, and State of New Jersey, have invented a new and Improved Device for Adjusting Transoms, of which the following is a specification:

In the accompanying drawing, Figures 1 and 2 represent side views of my improved device for adjusting transoms, showing the transom respectively in closed and open position.

Similar letters of reference indicate corresponding parts.

The object of this invention is to furnish an improved device for adjusting and locking transom-lights in any desired position with greater facility than by the devices at present in use; and the invention consists of the connection of the transom by a pivot-piece with a fulcrumed lever, and by an intermediate pivot-rod with the sliding and guided hand-rod that locks, by side pins, into a recessed guide-socket. The opening of the transom is facilitated by a projecting cheek of the fulcrumed lever, against which the pivot-bar, connecting hand-rod, and lever bear, so as to throw the fulcrumed arm out of its vertical position, all as hereinafter more fully described and claimed.

In the drawing, A represents a transom, that is hinged at the upper or lower end or pivoted to a suitable casing. To fixed side lugs or ears *a* of the same is pivoted a connecting-piece, B, that is again pivoted at its opposite end to a lever, C, which is fulcrumed to a fixed horizontal support, C', attached to the casing. The opposite end of the fulcrumed lever C is connected by a pivot-link to the swiveled pivot-lugs *b* at the upper end of the vertically sliding and guided hand-rod E. The hand-rod may, on account of the swiveled lugs, be turned readily on its axis, so as to lock, by projecting side pins *d*, into a recessed guide-socket, *d'*. At the lower end of the hand-rod is a suitable handle, by which the entire device is actuated and the transom raised or lowered.

The advantage of this construction consists

in the raising of the transom by the pulling of the hand-rod, which is thus more easily accomplished than by the raising or lifting action of the usual construction of such transom attachments.

By the projecting studs *d* of the axially-turning hand-rod and the recessed guide-socket *d'*, the transom may be set at any desired inclination, so as to admit more or less air.

The fulcrumed lever C assumes, when the transom is closed, a nearly-vertical position, and would not follow the downward motion of the hand-rod and connecting pivot-rod without providing some means by which the resistance of the fulcrumed lever may be overcome. For this purpose the lever is cast or otherwise provided at the upper end with a projecting cheek, *e*, that has the same inclination as that assumed by the piece D toward lever C when the transom is in closed position. When the hand-rod is pulled the connecting-piece D bears on the cheek, and throws first the fulcrumed lever out of its vertical position, and then, with great facility, into downward position, as in Fig. 2, admitting thereby the easy and convenient handling of the transom.

I am aware that it is not new, broadly, to operate a transom by means of a hand-rod, connected by suitable mechanism therewith; but

What I claim is—

1. The combination, with the mechanism B C D for operating a transom, of the swiveled hand-rod E, having side studs *d* and the recessed guide-socket *d'*, as and for the purpose specified.

2. The combination of transom A, pivoted connecting-piece B, and fulcrumed lever C, having projecting cheek *e* near upper pivot, with connecting pivot-piece D and sliding and guided hand-rod E, substantially as shown and described.

AUGUST F. PFEIFER.

Witnesses:

PAUL GOEPEL,  
R. A. HOWARTH.