

D. SHIELDS & R. Z. LIDDLE.  
Oil-Stove.

No. 200,770.

Patented Feb. 26, 1878.

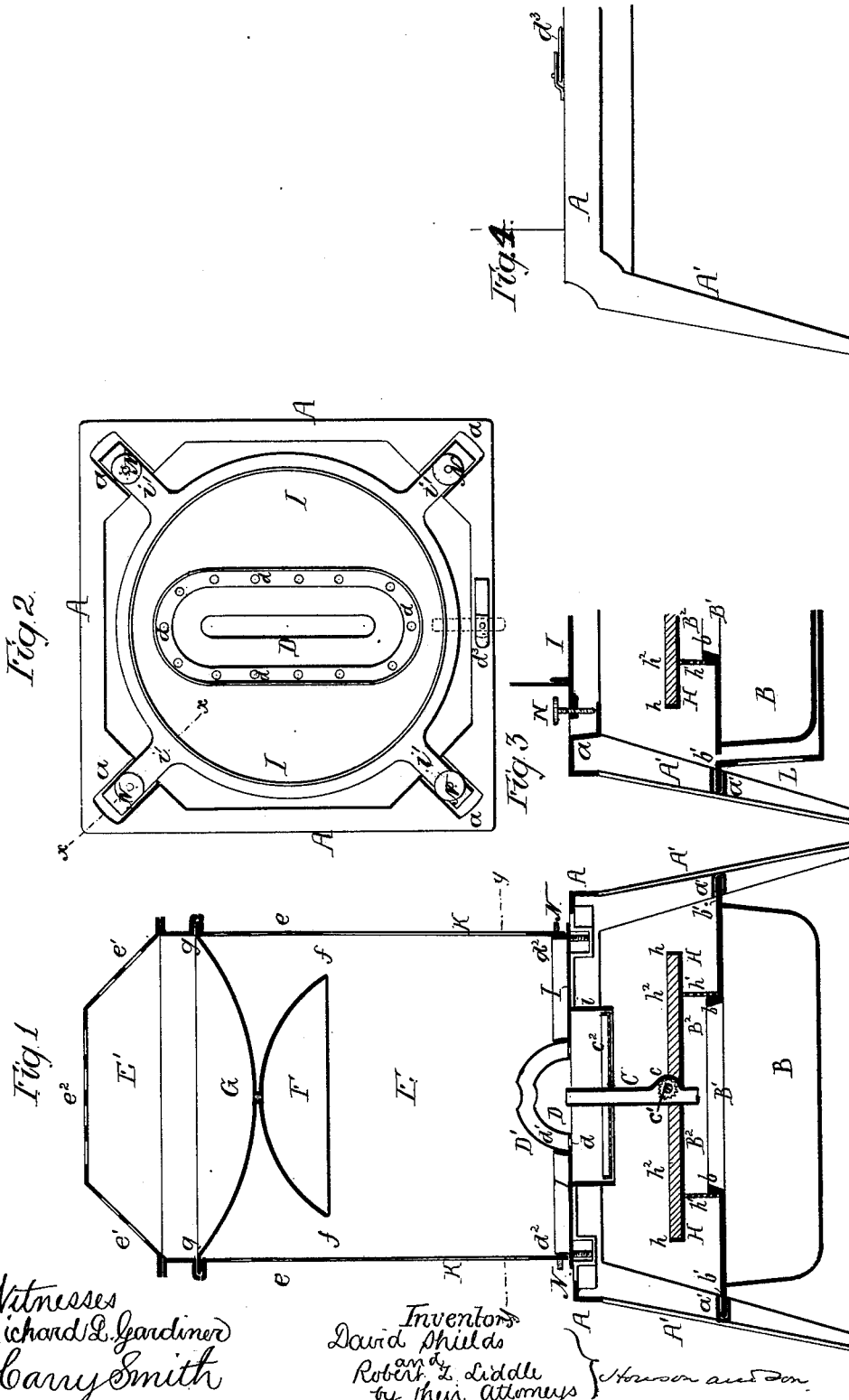

Witnesses  
Richard L. Gardiner  
Harry Smith

Inventors  
David Shields  
Robert Z. Liddle  
by their Attorneys } Horson and Son.

# UNITED STATES PATENT OFFICE.

DAVID SHIELDS, OF FLORENCE, MASSACHUSETTS, AND ROBERT Z. LIDDLE,  
OF ALBANY, NEW YORK.

## IMPROVEMENT IN OIL-STOVES.

Specification forming part of Letters Patent No. 200,770, dated February 26, 1878; application filed  
July 9, 1877.

*To all whom it may concern:*

Be it known that we, DAVID SHIELDS, of Florence, Massachusetts, and ROBERT Z. LIDDLE, of Albany, New York, have invented a new and useful Improvement in Oil-Stoves, of which the following is a specification:

Our invention relates to that class of stoves in which hydrocarbon oils are used as a fuel for heating, cooking, and other purposes to which it may be adapted.

Heretofore the great difficulty experienced in stoves of this class has been the keeping of the oil in the reservoir cool, in order to prevent the generation of gases and insure perfect safety; and the object of our invention is to overcome this difficulty and to improve generally stoves of this class in a manner too fully explained hereinafter to need preliminary statement.

In the accompanying drawings, Figure 1 is a vertical section of our improved stove for burning oil; Fig. 2, a plan view, showing the drum and the outer cone of the lamp removed; Fig. 3, a vertical section of part of the stove on the line *x x*, Fig. 2; and Fig. 4, a front view of a portion of the base of the stove.

The base or frame A of the stove is provided with appropriate standards A', carrying the reservoir B, and supporting the bottom plate or diaphragm I and heating-drum E. The reservoir is provided with flanges *b' b'*, so adapted to grooved guides *a' a'* secured to the standards A' that it can be drawn out from and returned to its proper position without being entirely detached from the structure.

Instead of supporting the reservoir directly on the standards A', it may be contained within and supported by a metal rack or basket, L, having flanges adapted to the above-mentioned grooved guides, as shown in Fig. 3, the reservoir in this case having no flanges and being isolated from the base or frame A.

We prefer to make the reservoir B of such metal as will permit the formation of its lower portion without seams or joints, through which the oil is very liable to leak.

In the top of the reservoir there is a central opening, B<sup>1</sup>, which is surrounded by an inwardly-inclined flange, *b*. There must also be in the top of the reservoir an opening for the

introduction and removal of the oil, the said opening being furnished with a suitable stopper. Surrounding the opening B<sup>1</sup> in the top of the reservoir, and adapted to the flange *b*, is a perforated casing, *h*<sup>1</sup>, for supporting a plate, H, which carries the wick-tube C, the latter being provided with a ratchet, *c*<sup>1</sup>, contained within the projection *c* of the tube, and fixed to a spindle, by manipulating which the wick can be raised or lowered. There is a flange, *h*, on the edges of the plate H, for retaining within the latter a layer, *h*<sup>2</sup>, of plaster or other equivalent non-conducting material, which prevents the transmission of the heat of the flame and wick-tube to the reservoir and its contents. This isolation of the reservoir is enhanced by the air-passages B<sup>2</sup> between the top of the flange *h* and the under side of the plate H, this passage also permitting the free escape of whatever gases may be generated in the reservoir.

A perforated plate, *c*<sup>2</sup>, is supported by the wick-tube, or in any other convenient manner, the flange at the edges of this plate fitting snugly within a flange, *i*, on the under side of the bottom plate or diaphragm I, which is provided with projections *i'*, furnished with set-screws N, Fig. 3, the points of each screw resting in a socket, *a*, in the corner of the frame A. These screws, in addition to the advantage gained by their limited bearing-surface in contact with the plate I, afford mediums through which the latter and its superstructure may be steadied and adjusted on the base.

D is an ordinary cone for regulating the flame, and D' a supplemental cone placed over the first, there being a space, *d*<sup>1</sup>, between the two cones for the passage of air admitted through perforations *d* in the plate I. E is the heating-drum, fitted at its lower end to a flange, *d*<sup>2</sup>, on the bottom plate or diaphragm I, and provided at the top with a cap, E', having openings *e*<sup>1</sup> and *e*<sup>2</sup>. There are similar openings *e* in the upper portion of the drum below the cap, and also larger openings K, to be fitted with mica for purposes of illumination.

Within the heating-drum, near the top of the same, is an inverted dome or cone, G, from which is suspended a second dome or cone, F,

the edges of the former being fitted tightly at *g* to the interior of the drum, but the dome F being of such diameter that there shall be an annular space, *f*, between the drum and the periphery of the said dome.

The highly-heated air passing upward through the drum E is received in the dome F, and there superheated prior to escaping first through the annular passage *f*, and thence through the openings *e*, while air admitted to the space above the inverted dome is discharged through the openings *e*<sup>2</sup>.

Before the reservoir or the rack which carries the same can be moved outward from the base for the purpose of trimming the wick, or for other objects, the front end of the plate or diaphragm I must be tilted upward for the passage of the wick-tube. In order that the plate and its superstructure may be temporarily sustained in this tilted condition, we provide the front of the base A with a turn-buckle, *a*<sup>3</sup>, Figs. 2 and 4, which can be introduced beneath the tilted plate, or can be withdrawn when the said plate has to be lowered.

We claim as our invention—

1. The combination of a base or frame hav-

ing recessed bearings *a* with the heating or cooking drum provided with projections *i*', through which pass set-screws N adapted to said bearings, all substantially as set forth.

2. The combination of the reservoir and its support L, having flanges *b*', with the guides on the base.

3. The combination, substantially as described, of the drum E, inverted cone or dome G, and a dome or cone, F, and annular space *f*.

4. The combination of the drum E, its domes or cones, and the annular space *f* with the openings *e e* in the drum.

5. The combination of the drum E, its inverted cone or dome G, and the openings *e*<sup>1</sup> and *e*<sup>2</sup> above said cone or dome.

In testimony whereof we have signed our names to this specification in the presence of two subscribing witnesses.

DAVID SHIELDS.  
ROBERT Z. LIDDLE.

Witnesses:

E. VAN SANTVOORD,  
W. H. T. WIAZ.