

D. M. SOMERS.

2 Sheets—Sheet 1.

Machine for Inserting and Clinching Metallic Staples.

No. 200,774.

Patented Feb. 26, 1878.

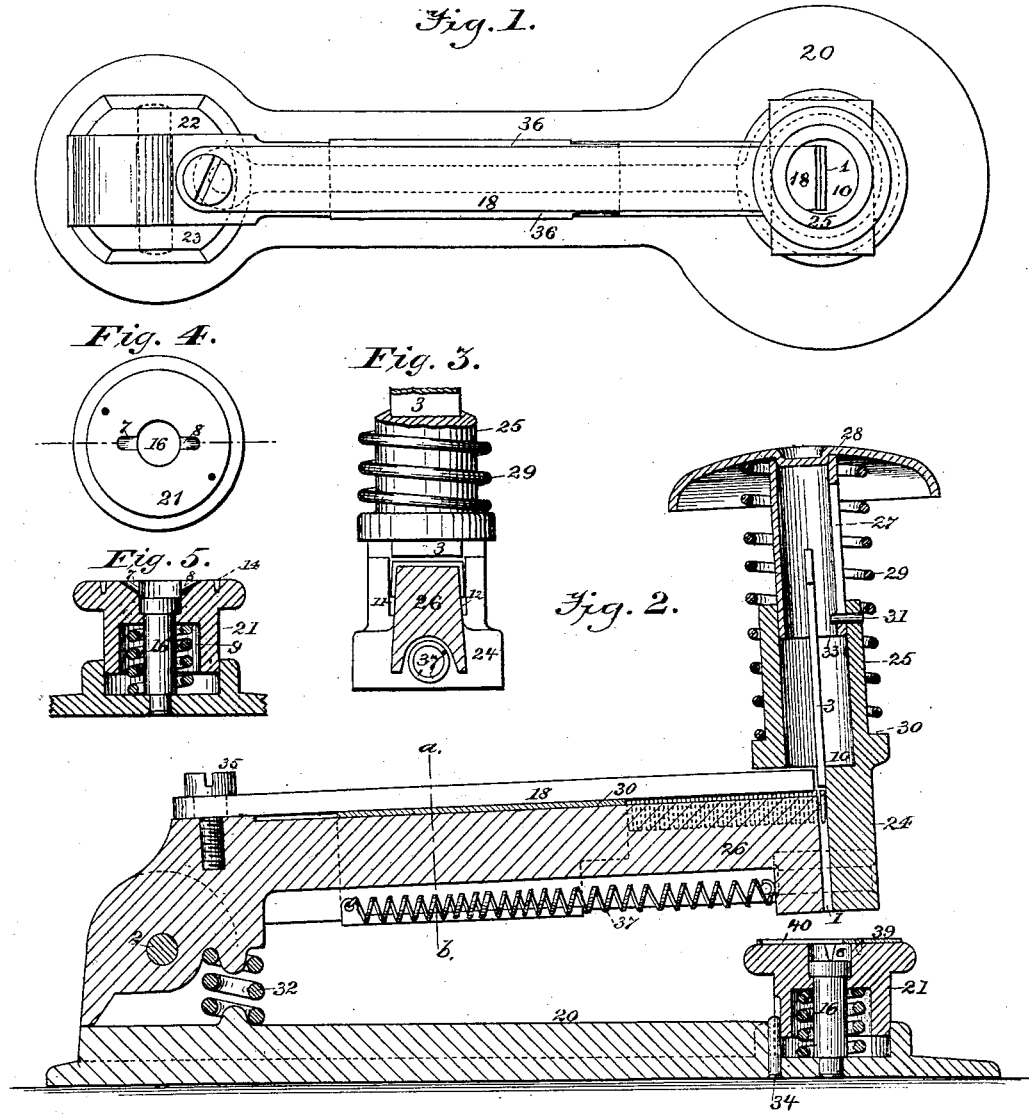

Attest;
A. Scott
M. Gardner

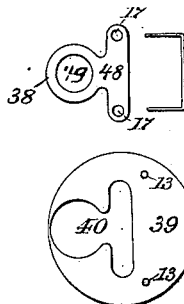

Fig. 6. Inventor
Daniel M. Somers,
by *Munson & Philipp*
attys.

D. M. SOMERS.

Machine for Inserting and Clinching Metallic Staples.
No. 200,774. Patented Feb. 26, 1878.

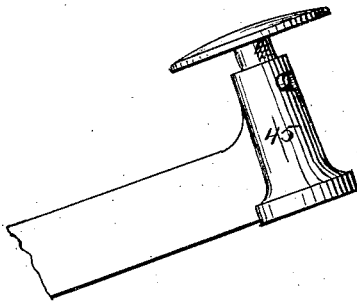
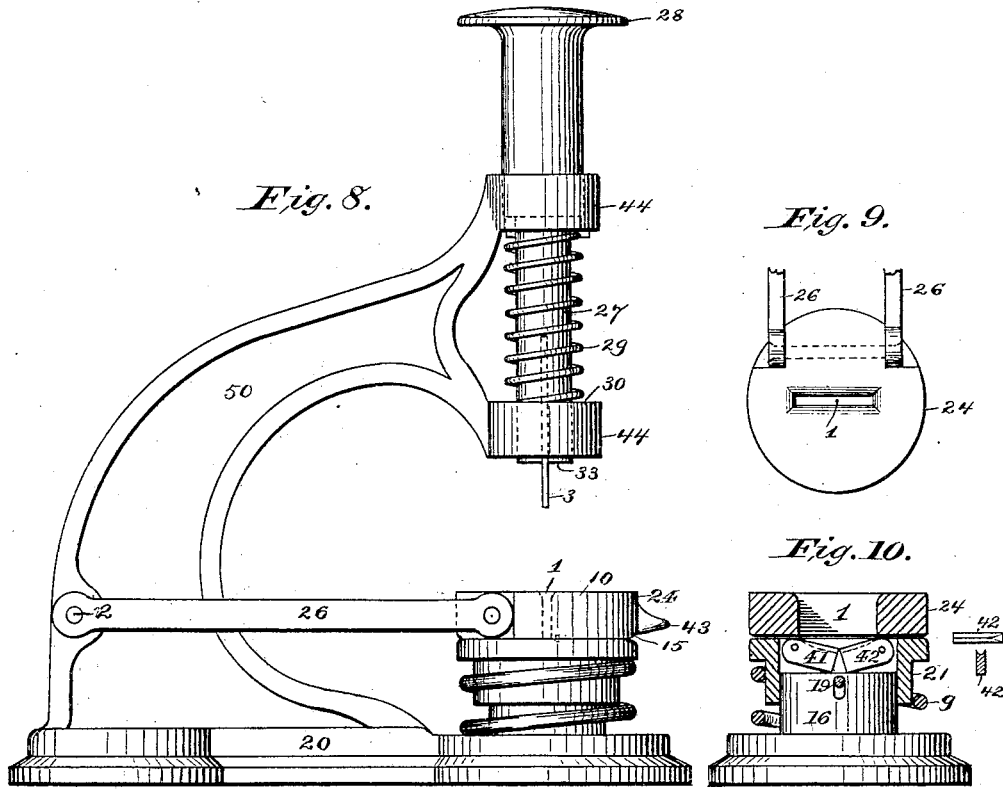

Fig. 11.

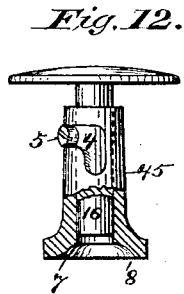

Fig. 12.

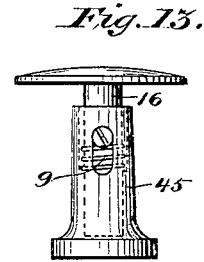
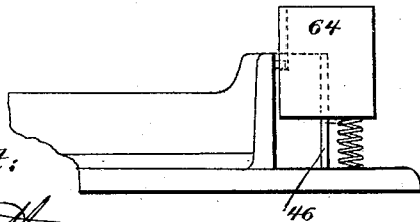

Fig. 13.



Attest:

A. Scott
My hand

Inventor:

Daniel M. Somers,
by Munson & Philipp
attys.

UNITED STATES PATENT OFFICE.

DANIEL M. SOMERS, OF NEW YORK, N. Y.

IMPROVEMENT IN MACHINES FOR INSERTING AND CLINCHING METALLIC STAPLES.

Specification forming part of Letters Patent No. **200,774**, dated February 26, 1878; application filed November 26, 1877.

To all whom it may concern:

Be it known that I, DANIEL M. SOMERS, of the city, county, and State of New York, have invented an Improvement in Machines for Inserting and Clinching Metallic Staples, of which the following is a specification:

This invention relates to that class of machines which are adapted to insert metallic staples through one or more thicknesses or sheets of paper, cloth, and similar material, and fasten the same by clinching their protruding legs down onto the face of the material.

The invention consists in a machine so constructed that one continuous operation of its devices inserts the staple through the material and clinches its legs down upon the face thereof, the particulars of which are too fully hereinafter set forth to need preliminary description.

In the drawings illustrating this invention, Figure 1 is a plan view of the machine; Fig. 2, a longitudinal section; Fig. 3, a rear elevation taken on the line *a b* of Fig. 2; Fig. 4, a plan view of the rest-block; Fig. 5, a section thereof taken on a line at right angles to that upon which the section, Fig. 2, is made. Fig. 6 shows a staple and a suspension-ring, and Fig. 7 a guide-plate, by the aid of which said suspension-ring may be attached by means of a staple. Fig. 8 represents a modification of the machine. Fig. 9 shows a plan view of the staple-guiding block, and Fig. 10 a section of the staple-guiding block and the rest-block. Figs. 11, 12, and 13 show the staple-clinching mechanism adapted to another form of staple-setting machine.

The machine, as illustrated in Sheet 1, is constructed as follows: A metal base-plate, 20, supports at one end, in a circular socket provided therein, a clinching-head, 21, and at the opposite end has upwardly-projecting lugs 22 23, between which a swinging arm, 26, is hung upon a pivot, 2. This swinging arm 26, which may gravitate or be upheld by a spring, as 32, supports at its forward end a staple-guiding block, 24, and a hollow standard, 25, in which a plunger, 3, and the plunger-stock 27 slide. This plunger-stock is surmounted by a cap, 28, and, together with the

plunger, is held in a raised position in the standard 25 by means of a spiral spring, 29, which, bearing on the under side of the cap 28, is coiled about said standard and seated upon a shoulder, 30, formed thereon.

The clinching-head 21 is formed with a circular body, which fits into the circular socket in the base-plate 20 in such a manner as to be capable of reciprocating therein, and it is prevented from turning horizontally by means of a guide-pin, 34, entering a slot in its side. This clinching-head is cored out at its under side to receive a spiral spring, 9, upon which it is seated, and it is held from vertical displacement by a clinching-anvil, 16, which has a shouldered head, the flange of which rests upon the bottom of a recess, 6, formed in the upper end of said head 21. The shank of the anvil 16 passes through the clinching-head 21, and is riveted in the base-plate. Two inclined slots, 7 8, opening into the recess 6, are cut into the face of this clinching-head, and their position and extent are such that they are aligned with and correspond in length to the slot 1 in the staple-guiding block 24. Their inclination is such that at their innermost ends their bottoms will preferably be nearly even with the upper face of the anvil 16, as is best observed in Fig. 5, and their inclination may form a straight or curved line, the latter being preferable, as their office is to bend the legs of a staple forced into them by the plunger 3 inwardly toward each other, so that they may be readily clinched down upon the material through which they protrude, as will presently more fully appear.

The plunger-stock 27 and the plunger 3, which is rigidly fixed to said stock, may, when the resistance of the spring 29 is overcome by pressure applied to its cap 28, slide in the standard 25, the plunger 3 moving in the guiding-slot 1, with which the staple-guiding block 24 is pierced, being prevented from protruding beyond the face of said guiding-block by the shoulder 33 of the plunger-stock 27, which seats itself upon the upper surface 10 of said block.

The swinging arm 26 is shaped in its cross-section so as to provide a flat top and slightly angular sides, as in Fig. 3, thus forming a

support adapted to receive and sustain a series of staples placed upon it, as in Figs. 2 and 3. These staples are held in place upon the arm 26 by means of a plate, 18, fixed by a pivot, 35, so as to oscillate over said arm 26, being moved to one side when the staples are being placed in position, and with its front end entering a recess cut into the standard 25 when holding said staples in place. (See Fig. 2.) This plate extends nearly up to the plunger 3, and, with the arm 26, forms a guideway which will perfectly direct the staples into the slot 1 in the guiding-block 24, passage-ways 11 12, Fig. 3, being cut into the rear sides of said block to admit the staples through it into said slot 1.

In order that the staples may be moved forward automatically, a feeding-slide, 36, fitting over the arm 26 and moving under the plate 18, is provided. This slide is attached to one end of a spring, 37, whose opposite end is fastened to the rear of the block 24, by the resilient power of which spring the said slide constantly presses the staples forward against the front face of the slot 1, thus always holding one staple in said slot, and consequently directly beneath the plunger 3 when the same is in its uppermost position, as in Fig. 2.

To operate this machine, the sheets of paper or other material designed to receive the staple and be fastened together by it, are placed in position upon the clinching-head 21, in the space between it and the staple-guiding block 24. The hand of the operator, pressing upon the cap 28, causes the swinging arm 26 to descend, thereby reciprocating the guiding-block 24, and causing it to clamp the material to be stapled between its face and that of the clinching-head 21; and when the guiding-block 24 is thus seated, a continued pressure upon the cap 28 will cause the plunger 3 to descend, and carry before it, through the slot 1, the single staple, which the feeding-slide 36 has forced into and holds suspended beneath it in said slot 1. As the plunger 3 bears upon the entire surface of the crown of the staple, and the staple-legs rest against the end walls of the slot 1, it is snugly confined on three sides, and is thus so rigidly supported that, as its legs are forced against the sheets of material, they will enter and pass through the same, and as they protrude beyond the lower surface of the material, they will enter the slots 7 8 in the clinching-head 21, and be turned or bent at angles toward each other. As the end of the plunger 3, when in its lowermost position, is flush, or nearly so, with the under face of the guiding-block 24, it follows that at that time the crown of the staple must be pressed down snugly upon the upper surface of the material through which it has been forced, and also that the protruding portions of its legs will have been bent toward each other as far as may be required by their length. And, as at this time the shoulder 33 of the plunger-stock is seated upon the upper surface 10 of the guiding-block 24, it also follows that any pressure then ex-

erted upon the plunger-stock will be transmitted through the guiding-block 24 and the material upon which it rests to the clinching-head 21, and if this pressure be sufficient to overcome the power of the spring 9, said clinching-head will be depressed or reciprocated vertically. Such a movement of the rest-block taking place while the clinching-anvil 16 remains stationary causes the bent ends of the staple-legs, which rest upon or over by this anvil, to be further bent, and thus clinched down flat upon the under surface of the material, while the plunger 3 remains seated upon the crown of the staple.

These operations are all caused by one continuous pressing movement applied to the cap 28, and when released the parts will all move upward together into the positions shown in Fig. 2, the stapled material being thus left free to be removed. The feeding-slide will also move forward and feed a new staple into the slot 1 under the plunger 3, so soon as it clears said slot, and the machine is ready to repeat the operation.

This machine is provided with means for attaching suspension-rings, such as that marked 38 in Fig. 6, which, though made of sheet metal in the common form—that is, with a ring, 49, and an attaching-shank, 48—has the ends of the latter perforated by holes 17 to receive the legs of the staple 51. To do this expeditiously a guide-plate, 39, having a recess, 40, in its face, into which the suspension-ring snugly fits, is adapted to be temporarily attached to the face of the clinching-head 21, as in Fig. 2, the means of its securement being pins 13, which enter holes, Fig. 5, therein. It is apparent that, when this guide-plate is adjusted in place, a suspension-ring, provided with the holes 17 and placed in the recess 40, will be attached to any material rested upon it, by means of a staple inserted and clinched by the mechanisms just described.

The mechanism for clinching the staple-legs may be of the construction shown in Fig. 10, wherein the clinching-head 21 is provided with a staple-leg-bending slot, as before, but which slot, in this instance, is provided at each end with pivoted clinchers 41 42, whose free ends rest upon the clinching-anvil 16. The upper faces of these clinchers are grooved, preferably to a depth equal to the thickness of the staple-legs, as is seen in the detached views of Fig. 10.

The clinching-head 21 is upheld, as before, by a spring, 9, which is here shown as applied outside of the anvil, and it has a pin, 19, limiting its upward movement.

In this modification the staple-guiding block 24, at the end of two swinging arms, 26, is shown as hinged to a standard, 50, and resting by gravity upon the clinching-head 21, as it may in the form of the machine shown in Fig. 2; and it is provided with an inclined front edge, as at 15, which may be extended as a finger-piece, 43. The object of this inclined edge, which may also be given to the

clinch-head 21, is to facilitate the entrance of the material, the edges of which thus readily enter between the guide-block 24 and clinching-head 21; or, by means of the said finger-piece, the guide-block 24 may be conveniently raised to facilitate the entrance of the work.

The stock 27, carrying the plunger 3, plays in heads 44, in which it is spring-seated, while the other parts of this modification corresponding to those in the main machine are marked with like reference characters.

To operate the machine thus modified, a staple is entered into the guiding-slot 1 with its legs downward, the ends and sides of said slot being rounded to facilitate its introduction. (See Figs. 9 and 10.) This having been done, and the material to be stapled placed between the block 24 and the clinching-head 21, as before, the plunger 3 is pressed down until it has entered the slot 1, engaged and carried the staple before it, forced the same through the material, and bent its legs inwardly by means of the inclined surfaces of the clinchers 41 42. This done, the shoulder 33 on the clincher-stock will have been seated upon the upper face 10 of the guiding-block 24, so that any further movement of it will, as before explained, cause the clinching-head 21 to descend. Now, as this clinching-head descends the stationary anvil 16 will cause the clinchers 41 42 to swing upon their pivots and press or bend the staple-legs snugly down onto the material, which may then be drawn out of the machine.

When the parts resume the position, Fig. 8, which takes place as soon as the pressure is removed from the cap 28, the operation may be repeated.

The clinching-head 21 might be made stationary, and the anvil 16 reciprocate within the same by means of an arrangement of levers operated at the proper time by the plunger 27. And in some instances the clinching mechanism may consist of a clinching-head, as 21, made stationary, and provided with a bending-slot, having its ends so inclined as to operate to turn the staple-legs down flat upon the material.

Either of the clinching mechanisms shown in Figs. 2 or 10 may be applied to an instrument which sets the staple with its legs uppermost—as, for instance, that forming the subject-matter of Patent No. 195,603, which requires one movement to insert the staple and bend its legs, and a second movement to clinch them. In that instrument a clinching-head, as 45, Figs. 10, 11, 12, is provided with a bending-recess, the ends 7 8 of which are inclined, which driving-head bends the legs of a staple supported on an anvil, 46, inwardly, as they are pressed into its bending-recess, by bringing said head 45 down onto the anvil 46. This done, the work is moved forward, so as to carry the staple in it out of alignment with the bending-recess and over the smooth surface of a block, 64; and a second move-

ment of the driving-head is made to press the staple-legs down onto the material.

In order to avoid the necessity for a second blow to clinch the bent staple-legs, the said clinching-head 45 is provided with my improved clinching mechanism—that is, the clinching-anvil 16 which slides therein may, when the clinching-head 45 is pressed down onto the material, be reciprocated to bear upon the bent staple-legs in the recess 7 8, and clinch the same snugly down upon the material before the parts clamping the same are disturbed with relation to each other or to the material operated upon. This clinching-anvil may be sustained against moving, with respect to the head 45, while the inserting operation is being performed, by means of a spring, 9, as in the structure, Figs. 1 to 10, or by a right-angular slot, 4, in which a stop-pin, 5, plays. In the latter form a swinging turn of the anvil at the end of the downward stroke of the clinching-head 45 permits its reciprocating movement.

When this form of the device is applied to the machine shown in Figs. 2, 8, a mechanical movement operated by the plunger 3 may throw off the stop-pin 5.

By my improvement, the movement necessary to insert the staple, bend its legs inwardly, and clinch them down upon the material, is practically a continuous or single one, which mode of operation is highly important and advantageous, as it does not admit of the staple getting out of place or canting before it is completely fastened or clinched into the material; and when the staples it sets are used as paper-fasteners, or for other similar purposes, this machine will be found desirable, for the reason that it so inserts the staples that their crowns are on the face side of the material.

The suspension-ring illustrated and described is not claimed herein; but

What is claimed is—

1. In a machine for setting staples, the combination, with a staple-inserting plunger, of a clinching-head, provided with a bending-slot, having inclined ends, and a clinching-anvil, the said clinching-head and anvil being constructed to reciprocate, with respect to each other, substantially as described.
2. The staple-clinching mechanism consisting of a reciprocating clinching-head, as 21, and a stationary anvil, as 16, having the clinchers 41 42, substantially as described.
3. The combination of the plunger 3, reciprocating staple-guiding block 24, and the clinching-head 21, having a bending-slot, with inclined ends, substantially as described.
4. The combination, with the reciprocating staple-guiding block 24, and the plunger 3 operating through the same, of the clinching-head 21 and clinching-anvil 16, substantially as described.
5. The combination with the swinging arm 26 and staple-guiding block 24, of the feeding-

slide 36 and passage-ways 11 12, substantially as described.

6. In a machine for setting staples, the combination of a reciprocating plunger, as 3, and a reciprocating staple-guiding block, as 24, with a staple-clinching mechanism, whereby the latter mechanism is automatically operated by said plunger, substantially as described.

7. The combination of the guide-plate 39,

having a recess, 40, with the clinching-head 21 and staple inserting and clinching mechanisms, substantially as described.

In testimony whereof I have signed my name to this specification in the presence of two subscribing witnesses.

DANIEL M. SOMERS.

Witnesses:

H. T. MUNSON,
M. B. PHILIPP.