

R. CARTWRIGHT.
Hopper for Pneumatic Dredging-Scows.
No. 200,821. Patented March 5, 1878.
Fig. 1

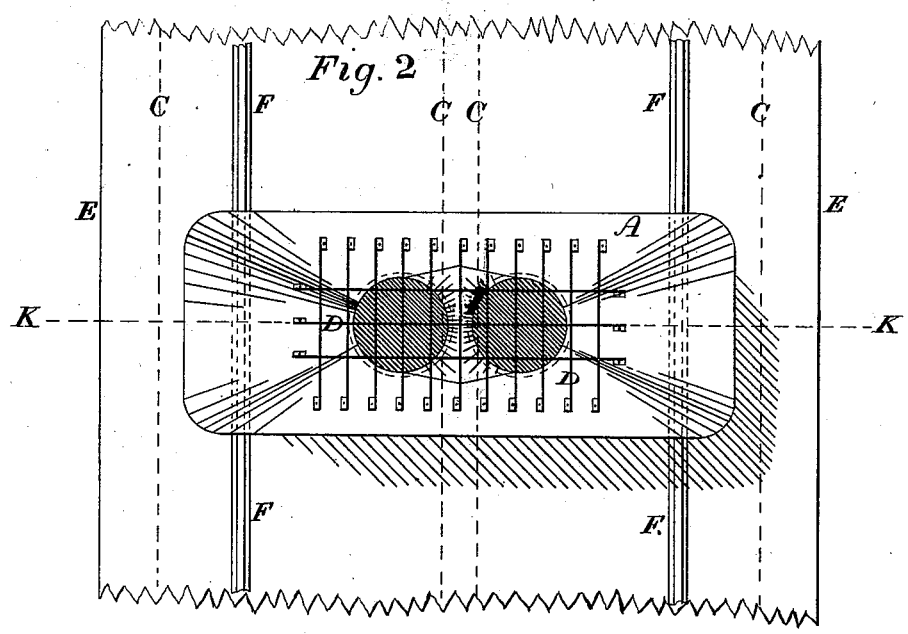
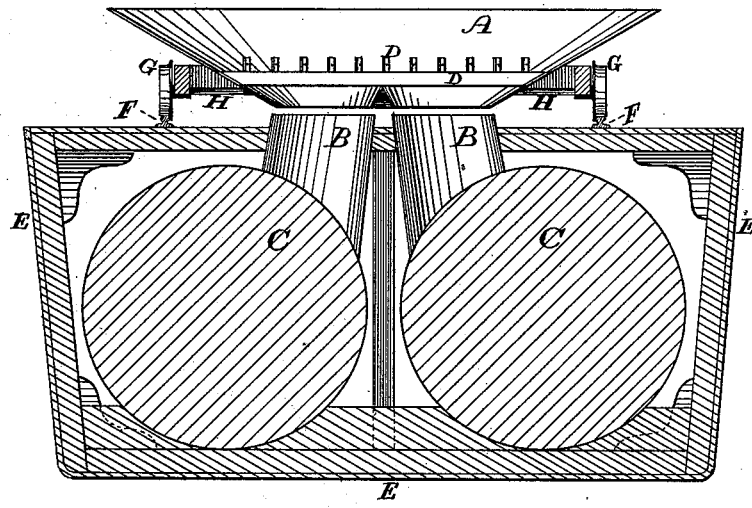

Attest:
Harry Jackson
Waldo S. Morse.

Inventor
Robt Cartwright

UNITED STATES PATENT OFFICE.

ROBERT CARTWRIGHT, OF ROCHESTER, NEW YORK.

IMPROVEMENT IN HOPPERS FOR PNEUMATIC DREDGING-SCOWS.

Specification forming part of Letters Patent No. **200,821**, dated March 5, 1878; application filed January 28, 1878.

To all whom it may concern:

Be it known that I, ROBERT CARTWRIGHT, of Rochester, in the county of Monroe and State of New York, have invented a new and useful Improvement in the Hoppers for Pneumatic Scows, which improvement is fully set forth in the following specification and in the accompanying drawings, in which—

Figure 1 is a transverse section of the scow at the point designated by a dotted line and letters K K on Fig. 2, showing hopper, chutes, and cylinders. Fig. 2 is a plan of a portion of the scow, showing the hopper with grating, as herein described.

The nature of my invention applies to rendering the material being dredged of such form as to permit its being discharged by pneumatic pressure more readily than if allowed to drop into the cylinders or tanks in large bulk.

In order to explain my invention, I will describe dredging by the pneumatic process.

Tanks or cylinders are placed in the hold of a scow of such capacity as may be required, said tanks being nine or ten feet in diameter and sixty or seventy feet long, and having at one end, on the bottom, a discharge-pipe, say, two feet diameter. A system of small pipes is arranged inside, near the bottom, through which air and water are forced. The air and water, percolating the material in the tanks, cause it to assume a semi-fluid condition, and by the accumulation of the air-pressure the material is ejected through the discharge-pipe to such location as may be desired, the discharge-pipe being sometimes a thousand feet long. With clay or river-mud the material is so tenacious and compacted that it will not discharge itself, and the herein-described invention is for the purpose of reducing the mass to such sizes as the more readily to assimilate with the water, and to pass freely out of the discharge-pipe.

In the drawings, E E represent portions of

the pneumatic scow, having upon its deck rails F F, running fore and aft of the scow. A A is a hopper, set upon a frame, H H, said frame being provided with car-wheels G G, as shown. C C are large tanks or cylinders, running lengthwise of the scow, and being in the hold. B B are chutes or tubes, forming the connection between the bottom of the hopper A and the tanks C, and through which the tanks are filled with the material. There are several of these chutes on the tanks at intervals, for the purpose of distributing the material inside, so as to trim the scow. Each chute is fitted with a cap, making it air-tight.

As the tanks are filled with material below one set of chutes, the hopper is moved to another until the tanks are filled as much as may be desired.

D D are bars, forming a grating in the hopper. Said bars may have their top edges sharp or beveled, the better to cut up the clay or other material into such size as to facilitate its ready assimilation with the water, and enable it to pass through the discharge-pipe of the tanks, serving also to arrest any sticks, stumps, or stones that otherwise might pass into the tanks and lodge and clog up the discharge-pipe.

In dredging comparatively dry material to load the tanks, it may be necessary to lubricate the bars or grating to prevent its clogging. In such an event a stream of water thrown on it will afford the desired relief.

Having thus described my invention, I claim as new and desire to secure by Letters Patent—

The grating D D, adapted to cut up the dredged material, in combination with tanks C C, having inlets B B, as shown, and for the purpose described.

ROBT. CARTWRIGHT.

Witnesses:

HARRY JACKSON,
WALDO G. MORSE.