



W. HAILES & J. GRAY.  
Coal-Oil Stove.

No. 200,864.

Patented March 5, 1878.

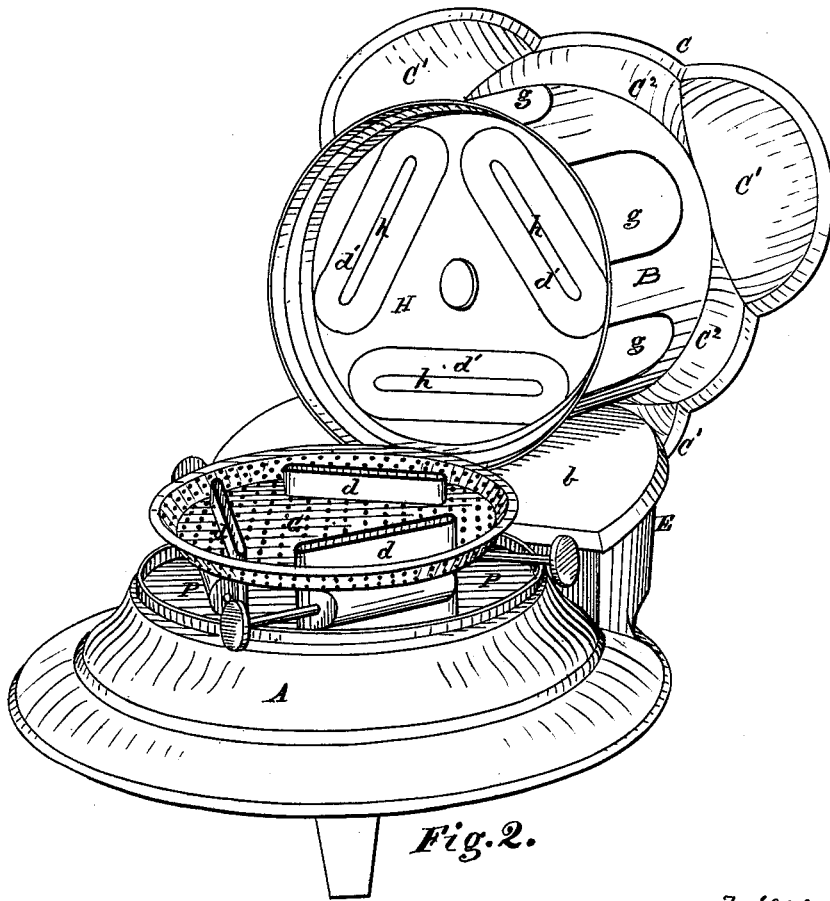

Fig. 2.

Witnesses {  
 William F. Selkirk  
 Chas. J. Selkirk

William Hailes  
 James Gray  
 Inventors.  
 By their Attorney  
 Alex. Selkirk.

W. HAILES & J. GRAY.  
Coal-Oil Stove.

No. 200,864.

Patented March 5, 1878.

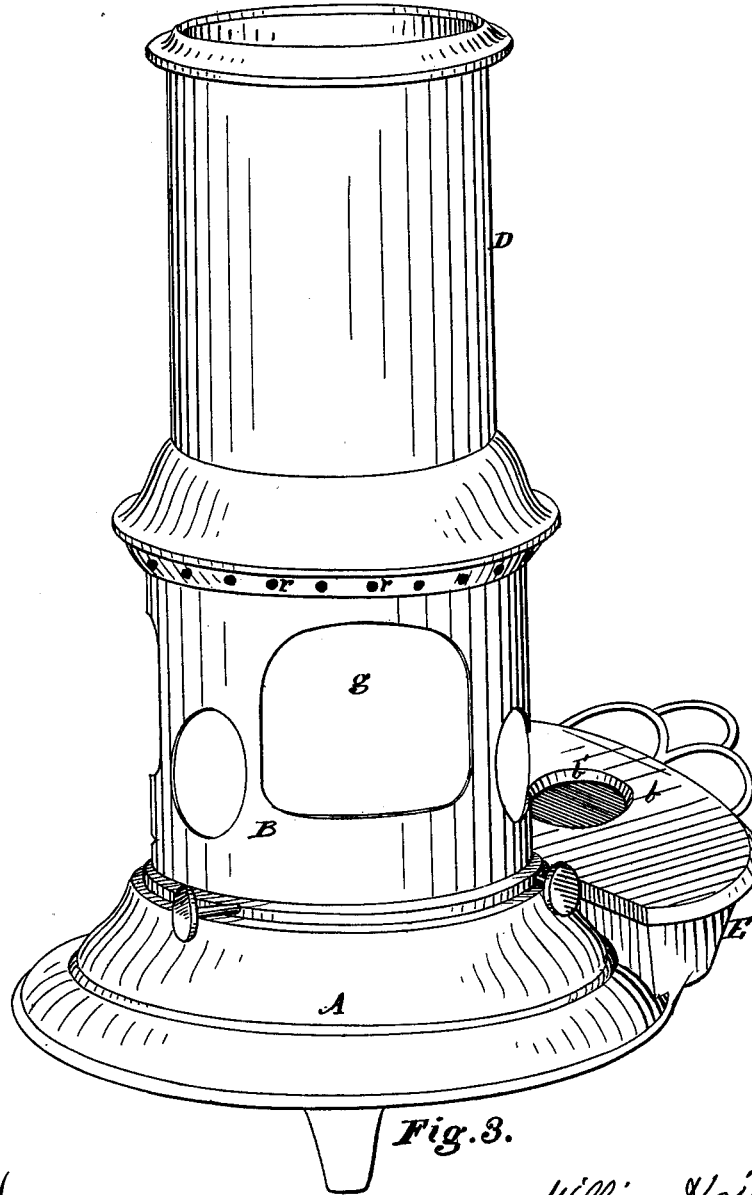

Fig. 3.

Witnesses. {  
 William F. Subbitt  
 Chas. J. Seckitt

William Hailes  
 James Gray  
 Inventors.  
 J. H. Allen  
 Alex. Seckitt

W. HAILES & J. GRAY.  
Coal-Oil Stove.

No. 200,864.

Patented March 5, 1878.

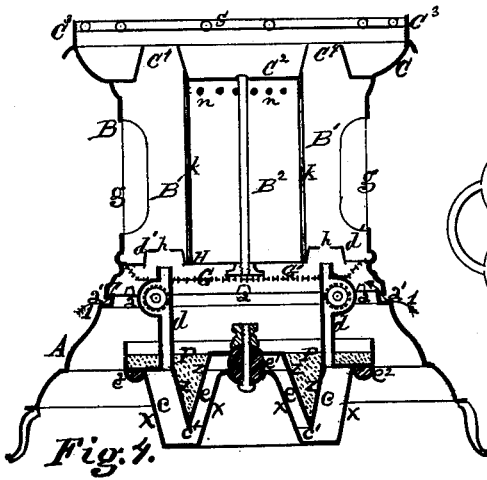

Fig. 1.

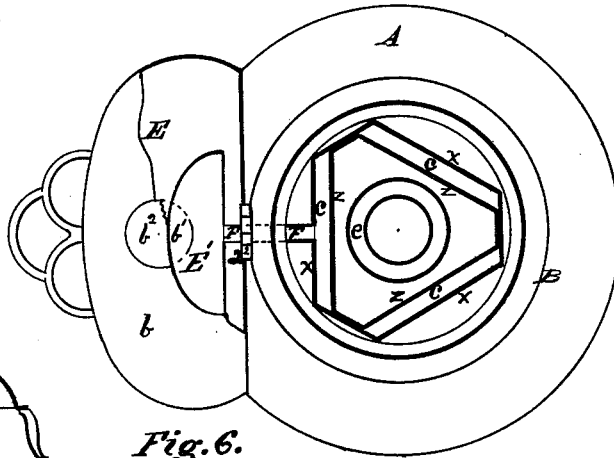

Fig. 6.

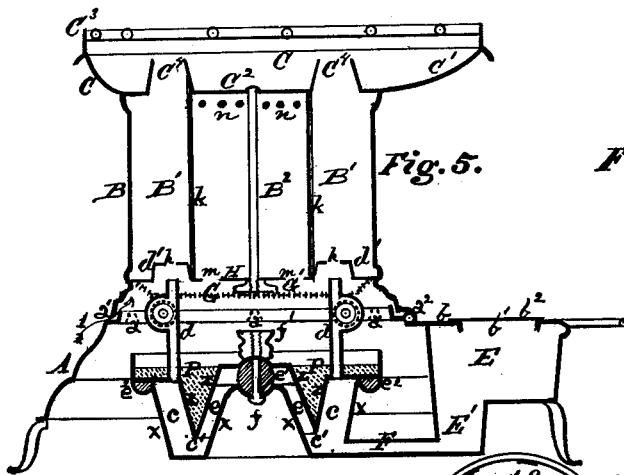

Fig. 5.

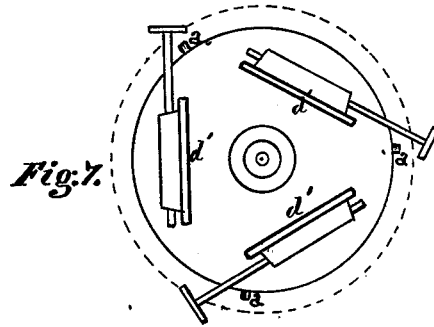

Fig. 7.

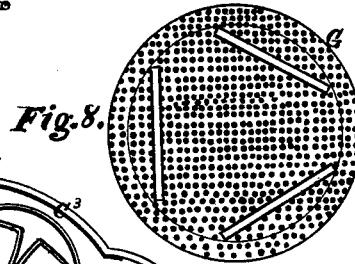

Fig. 8.

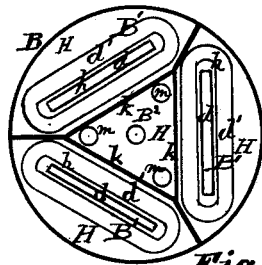

Fig. 9.

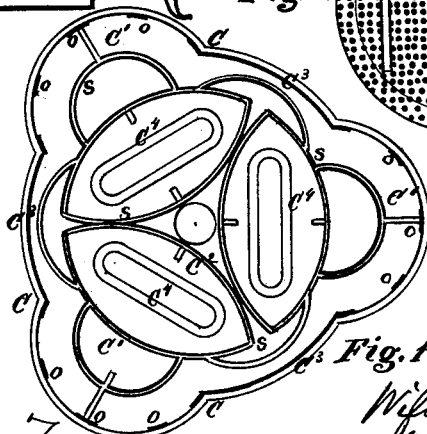

Fig. 10.

Witnesses

William F. Selbink  
Chas. J. Selbink

William Hailes  
James Gray  
of their atty  
Chas. J. Selbink,  
Inventors.

W. HAILES & J. GRAY.  
Coal-Oil Stove.

No. 200,864.

Patented March 5, 1878.

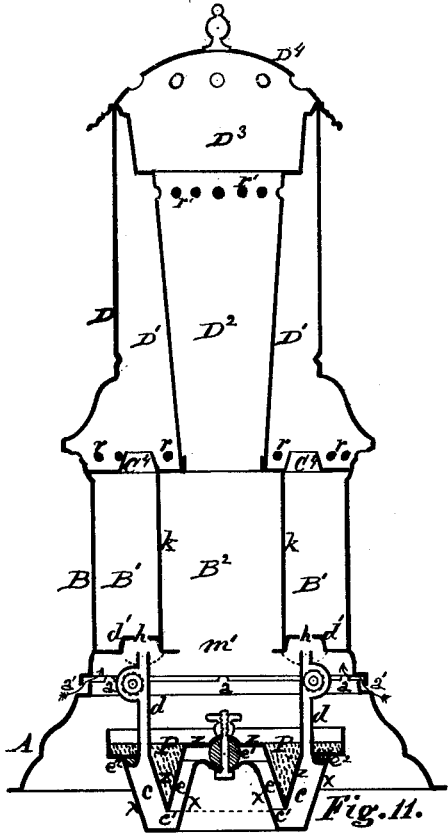

Fig. 11.

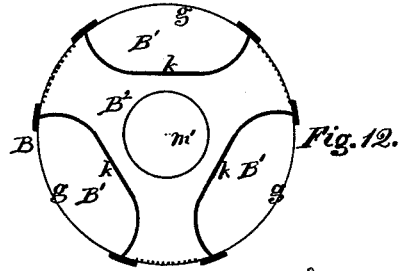

Fig. 12.

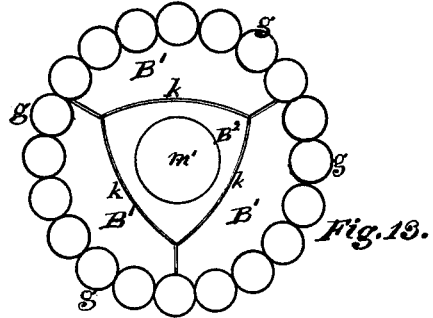

Fig. 13.

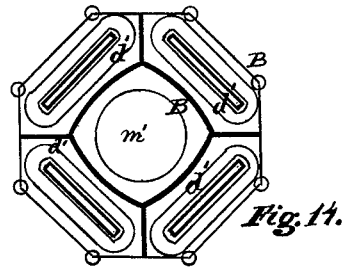

Fig. 14.

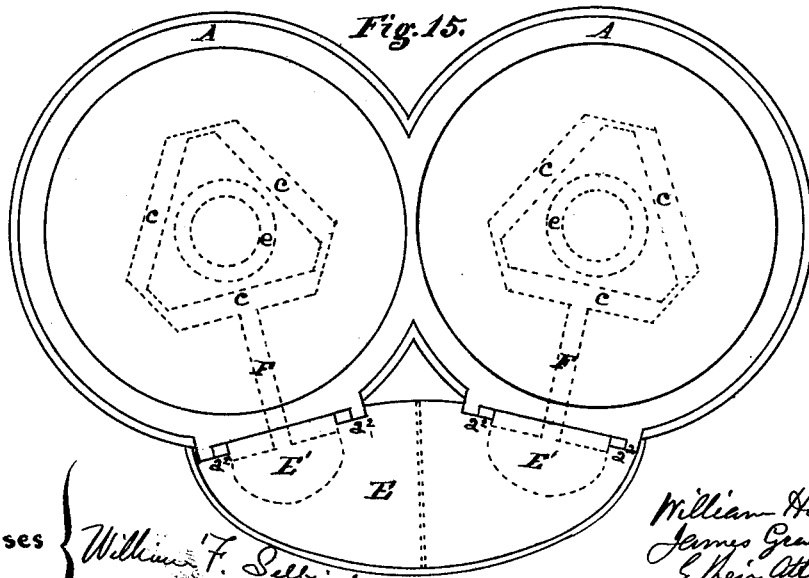

Fig. 15.

Witnesses

*William F. Selwick*  
*Chas. J. Sierant*

*William Hailes*  
*James Gray*  
*of their Attorneys*  
*Alex. Selwick*  
**Inventors.**

# UNITED STATES PATENT OFFICE.

WILLIAM HAILES AND JAMES GRAY, OF ALBANY, NEW YORK.

## IMPROVEMENT IN COAL-OIL STOVES.

Specification forming part of Letters Patent No. **200,864**, dated March 5, 1878; application filed March 27, 1877.

*To all whom it may concern:*

Be it known that we, WILLIAM HAILES and JAMES GRAY, both of the city and county of Albany and State of New York, have invented certain new and useful Improvements in Coal-Oil Stoves, which improvements are fully set forth in the following specification and accompanying drawings in five sheets, in which—

Figure 1 represents a perspective view of a coal-oil stove embodying the improvements in this invention, and adapted for cooking purposes. Fig. 2 is a perspective view of the same, illustrating the combustion-chamber section turned over from the base. Fig. 3 is a perspective view of the same adapted for heating purposes. Fig. 4 is a sectional elevation taken from side to side. Fig. 5 is a sectional elevation taken from front to rear. Fig. 6 is a plan view of the base and the arrangements of the parts connected with the same. Fig. 7 is a plan view of the arrangement of the burners. Fig. 8 is a plan view of the perforated diaphragm below the upper ends of the wick-tubes. Fig. 9 is a horizontal sectional view taken through the combustion-chamber B, Figs. 4 and 5. Fig. 10 is a plan view of the cooking-section. Fig. 11 is a sectional elevation of the stove adapted for heating purposes. Figs. 12, 13, and 14 are horizontal sectional views taken through the combustion-chamber B, Figs. 4, 5, and 11, illustrating modifications of the form of construction of the combustion-chamber section that may be employed; and Fig. 15 is a plan view of a duplex stove made with the improvements in this invention.

The object of our invention is to produce, in stoves for burning coal-oil, devices or means by which oil may be supplied to the wicks in a uniform manner without danger of explosion of gases, the wicks be held in separate chambers free from entanglement with each other, the flames be made to burn in separate chambers, and the hot products of combustion be conducted directly against the bottom or bottoms of the vessels placed on the stove, and made to move outward in contact with said bottom or bottoms without the outer atmosphere affecting the said hot products of combustion in the least.

In the drawings, A represents the base of

the stove, to which is hinged, by hinge  $a^2$ , the combustion-chamber B and its adjunctive parts. They are supported from the said base by several projecting pieces,  $a$ , cast solid with said base. An air-passage,  $a^1$ , is thus made between the combustion-chamber and base, through which the air may pass or circulate, as indicated by arrow 1 in Figs. 4 and 5.

C is the cooking-chamber section, and D is the heating-section, intended to be employed with the combustion-chamber section for heating purposes when said cooking-section is not employed, the said two sections being intended to be used interchangeably with each other, as may be required.

Made continuous with the base A, and located at the rear side of the same, is the oil-reservoir E, provided with a tight cover,  $b$ , having a flanged opening,  $b^1$ , through which oil is introduced to supply said reservoir. The said opening is closed by a stopper,  $b^2$ .

Made in the bottom of the reservoir E is a sub-reservoir,  $E'$ , having a small extension in a horizontal direction, and with a depth below the reservoir E sufficient to bring the bottom of said sub-reservoir on a plane with the bottoms of the wick-chambers  $c c c$ , located centrally within the base-section.

A supply-tube, F, connects the said sub-reservoir with said wick-chambers, and conducts the oil to be burned to the same.

The wick-chambers  $c c c$  are arranged in relation with each other, so as to be in a polygonal form, as shown, they communicating with each other at their bottoms, so as to lead the oil supplied by the supply-tube F from one chamber to another.

Communicating with the wick-chambers  $c c c$  is the air-chamber  $e$ , Figs. 4, 5, and 6, which air-chamber commences near the bottoms of the wick-chambers and extends upward to about the same plane with the upper ends of said wick-chambers.

The wick-chambers and connecting air-chamber are produced by means of the reversed angular plate  $z z$  sitting within the reversed angular plate  $x x$ , as shown in Figs. 4, 5, and 6. The said two plates thus forming the air and wick chambers are made gas-tight at their lines of connection by a rubber ball,  $e^1$ , central

between plates *x* and *z*, and the rubber gasket *e*<sup>2</sup> at the outer periphery of said plates, and by the additional use of the central draw-bolt *f* provided with a thumb-nut, *f'*, by which the said two plates are drawn toward each other, and bind on the gasket and ball between. The inner surface-walls of said wick-chamber and air-chamber are coated with enamel or other substance through which the oil will not pass.

Leading from each wick-chamber is a wick-tube, *d*, provided with a wick-raising wheel and thumb-wheel, such as heretofore employed for raising and lowering wicks of oil-lamps. Placed a little below the upper end of the wick-tubes *d d* is the perforated diaphragm *G*, made of a saucer shape, with its outer sides or rim inclined, as shown in Figs. 4 and 5. Above the diaphragm *G* is the solid or imperforated plate *H*, provided with arches or caps *d' d'*, having slots *h h* directly over the ends of the wick-tubes *d d*, through which slots the flames burn.

The combustion-chamber *B*, in which the flames of the several wicks burn, may be made of metal, or metal set with mica or glass, or wholly of glass, and may have a circular or other form, as may be elected. The interior of said chamber is divided into three or more compartments or flues, *B<sup>1</sup>B<sup>1</sup>*, which we denominate "flame-chambers," and an interior air-chamber, *B<sup>2</sup>*, formed by the plates *k k*, Figs. 4, 5, 11, 12, and 13. The flame-chambers *B<sup>1</sup>B<sup>1</sup>* are each formed by a plate, *k*, and a portion of the wall of the combustion-chamber section opposite, and are intended to operate as flues, to conduct the hot products of combustion to the horizontal and radial flues in the cooking-chamber section above.

The cooking-section *C* is composed of a single plate, made with horizontal flues *C<sup>1</sup>C<sup>1</sup>*, running radial from the exits *C<sup>4</sup>C<sup>4</sup>*, made with the bottom *C<sup>2</sup>* of the said cooking-section, as shown in Figs. 5 and 10. The said horizontal flues are made with concave bottoms, as shown in Fig. 5, which extend outward considerably beyond the intermediate vertical wall *C<sup>3</sup>*, and are intended to operate as passage-ways for the hot gases, from the exit *C<sup>4</sup>* beneath the bottom of any vessel placed over the said exits and their said radial horizontal flues, of which flues the bottom of the vessel thereon will form the upper plate in effect. The upper edges of the flues *C<sup>1</sup>* most remote from the exits *C<sup>4</sup>* terminate on or about the same plane with the upper ends of said exits, and are provided with a series of short standards, *O O*, projecting upward and terminating on a plane with the upper edge of the intermediate walls *C<sup>3</sup>*. The said standards are intended to operate as supports for that portion of a vessel that may extend over the farthest projection of said horizontal flues. A skeleton platform, *S*, is placed over the said cooking-section, to form an open-work platform for the support of several vessels or sad-irons, as may be required to be used.

The central air-chamber *B<sup>2</sup>* in the combustion-chamber section is supplied with air drawn from chamber *G* through several small openings, *m m*, Figs. 4 and 5, or through a large opening, *m'*, Fig. 11. In the upper portion of the walls of the air-chamber are made a series of openings, *n n*, through which the air heated in the air-chamber may escape into the combustion or flame chamber at a point slightly below the exits.

When the cooking-section is not employed, and it is desirable to employ the stove for warming purposes, the heating-section *D* is to be placed over the combustion-chamber section, the cooking-section first being removed. The said heating-section is composed of an outer annular chamber, *D<sup>1</sup>*, and a central air-chamber, *D<sup>2</sup>*, made continuous with the air-chamber *B<sup>2</sup>*. At the base of the outer chamber *D<sup>1</sup>* are made a series of small openings, *r r*, through which air may be admitted into said chamber, to be heated by the heat rising through exits *C<sup>4</sup>* from the chambers below. The inner wall of the said outer chamber is made flaring outward as it runs upward, so as to incline over the exits *C<sup>4</sup>* and become heated. In the upper portion of the said flaring wall is made a series of openings, *r<sup>1</sup>r<sup>1</sup>*, through which the air in the chamber *D<sup>1</sup>* may pass, to enter the upper portion of the inner chamber *D<sup>2</sup>* and pass out into the super-chamber *D<sup>3</sup>*. A cover, *D<sup>4</sup>*, provided with openings, through which the heated air may escape, is also provided. The said cover may be removed, and a vessel may be set over the said super-chamber for heating water.

To prevent the wick-chambers becoming heated, we cover the plate *z z* with plaster-of-paris or other non-conducting material, which will prevent the downward flashing of heat from the burners above heating the said wick-chambers.

It may be readily seen that, by the arrangement of the air-chamber *e* with the wick-chambers and their supply-pipe and oil-reservoir, the air in said chamber will prevent the oil rising up to a line with the tops of the said wick-chamber, while at the same time it will operate to press back on the oil in the reservoir through the supply-tube, and thereby exert on the oil in the wick-chambers a degree of pneumatic pressure equal to the weight of the oil in the reservoir. By forming the said wick-chambers and air-chamber of the plates *x* and *z* with corresponding reverse angles of wall-surfaces, and uniting the said plates, by means of a single bolt, with packings *e<sup>1</sup>* and *e<sup>2</sup>* between, the said plates may be readily separated to expose their inner surfaces for cleaning or other purposes, as may be required.

It may also be readily seen that by dividing the combustion-chamber section by the vertical walls *k k* each flame may have its own chamber to burn in, while the said plates will at the same time operate to prevent any excessive diversion of heat from a passage through the exits above.

By reason of the attachment to the cooking-section of the horizontal flues  $C^1$  radial from the exits  $C^4$ , and having the vertical intermediate walls  $C^3$ , when a vessel is placed over the said flues they will operate to lead the hot gases from the said exits outward to a considerable distance, and cause them to move in contact with the bottom of the vessel sitting over the same, in which case the bottom of the vessel will form, in fact, the top plates of said flues, while at the same time the air of the room will be prevented from mingling with the hot gases until they have been made to pass the full distance or length of said flues, in contact with the bottom of the vessel thereon.

It may also be readily seen that, by the heating-section being composed of an outer and inner chamber, with a tapering form of dividing-wall between, and provided with the openings above described, the air entering within said chambers will become highly heated by reason of the heating of the tapering dividing-wall, which will cause said wall to act as a radiator, to heat the air moving upward through said chambers, which air will, when heated, escape into the room.

Another advantage is that the air of the room will be kept in circulation by the heated air being continuously replaced by fresh cool air.

Having described our invention, we claim—

1. The combination, with the oil-reservoir E, supply-pipe F, and wick-chambers  $c c c$ , of the air-chamber  $e$ , communicating with said wick-chambers near the bottom of the same, substantially as and for the purpose set forth.
2. The combination of plates  $x$  and  $z$ , each

having the form shown and described, with the rubber packings  $e^1$  and  $e^2$ , bolt  $f$ , and nut  $f'$ , substantially as and for the purpose set forth.

3. The combination, with the combustion-chamber section and burners, of vertical partition-plates  $k k$ , arranged polygonally, and separating an inner air-chamber from the flame-chambers, substantially as set forth.

4. In an oil-stove, the combination, with the combustion-chamber section, of the cooking-section C, having radial horizontal flues  $C^1 C^1$  leading outward from exits  $C^4 C^4$ , and separated from each other by the intermediate vertical walls  $C^3 C^3$ , when all are arranged to adapt said horizontal flues to lead the hot gaseous products from the said exits outward and in contact with the bottom of a vessel placed over the same, substantially as and for the purpose set forth.

5. The combination, with the combustion-chamber section and a central air-chamber receiving air from beneath, of the heating-chamber, composed of an air-chamber provided with vent-openings above, and inclosed by an outer chamber situated vertically over the said combustion-chamber section, said outer chamber being provided with openings at its base, and having a tapering form of dividing-wall between said outer chamber and said heating-chamber, all arranged and constructed in the manner and for the purpose set forth.

WM. HAILES.  
JAMES GRAY.

Witnesses:

ALEX. SELKIRK,  
WILLIAM F. SELKIRK.