

C. E. ALBRO.
Hoisting Apparatus.

No. 200,961.

Patented March 5, 1878.

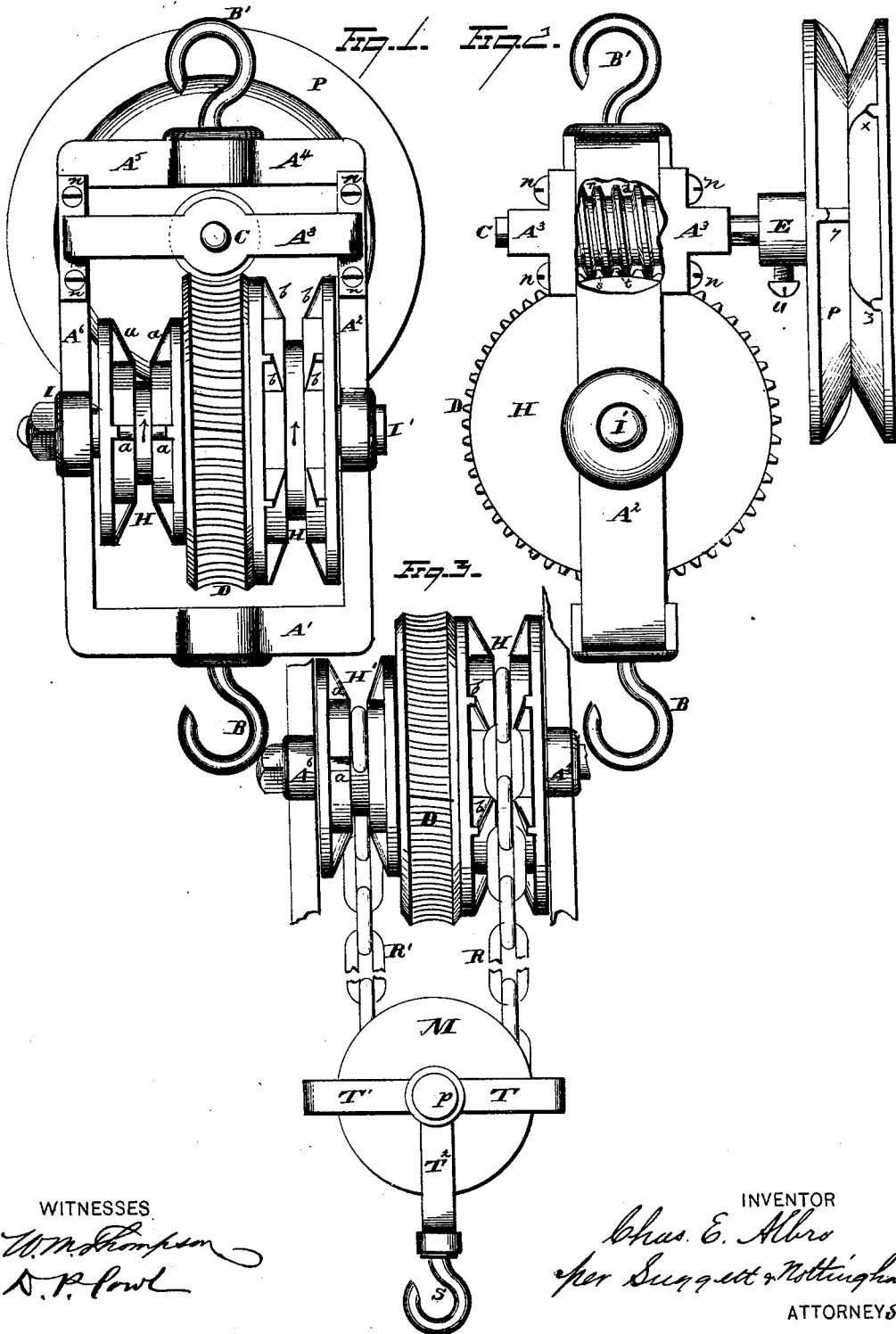

WITNESSES
W. M. Thompson
A. P. Low

INVENTOR
Chas. E. Albro
per Suggert & Nottingham
ATTORNEYS

C. E. ALBRO.

Hoisting Apparatus.

No. 200,961.

Patented March 5, 1878.

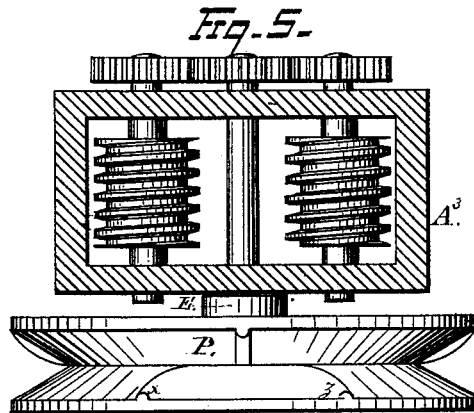
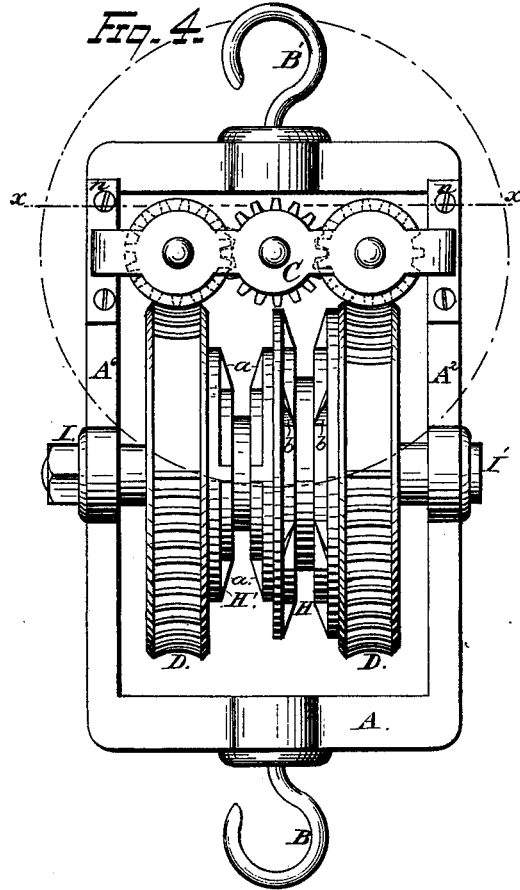

WITNESSES

W. M. Thompson
D. P. Fowl

INVENTOR:

Chas. E. Albro
per Suggett & Nottingham
attys

UNITED STATES PATENT OFFICE.

CHARLES E. ALBRO, OF CORTLAND, NEW YORK.

IMPROVEMENT IN HOISTING APPARATUS.

Specification forming part of Letters Patent No. **200,961**, dated March 5, 1878; application filed December 22, 1877.

To all whom it may concern:

Be it known that I, CHARLES E. ALBRO, of the village of Cortland, county of Cortland and State of New York, have invented new and useful Improvements in Self-Sustaining Differential Hoisting Apparatus, which improvements are fully set forth in the following specification and accompanying drawings, reference being had to the said drawings, and to the letters and figures of reference marked thereon.

The object of my invention is to provide a self-sustaining differential hoisting apparatus, the mechanism of the same being placed in a suitable frame-work or shell, so that it can be used like an ordinary pulley-block to raise and lower heavy weights, as required in machine-shops, and for the various other purposes for which the ordinary pulley-block and tackle and differential pulleys are now used.

My invention relates to that class of hoisting apparatus in which the mechanism of the same is placed in a suitable frame-work, and can be hung up or suspended like an ordinary pulley-block; and my invention consists in a suitable frame, in which is journaled a shaft carrying two differential pulleys, between which is mounted a worm-gear wheel, in combination with a screw mounted in bearings detachably secured to the frame, said screw being adapted to mesh with the worm-wheel, thereby making the common endless screw, and carrying a drive-wheel on one end, the whole being constructed to operate as more fully hereinafter specified.

In the drawings, Figure 1 is a side view of my self-sustaining differential hoisting apparatus. Fig. 2 is a plain side view of another side of the apparatus, with part of the side broken away, showing the endless screw. Fig. 3 represents a front view of the wheel part of the endless screw and the differential pulleys, with a portion of the supporting-frame. Fig. 4 represents a view showing the wheel part of two endless screws, the connecting spur-wheels, and a different arrangement of the differential pulleys with the supporting-frame. Fig. 5 represents a horizontal sectional view on the line *xx* of Fig. 4.

In the drawings the same letters on the different figures indicate the same parts.

In the drawings, A^1 , A^2 , A^3 , A^4 , A^5 , and A^6 is the frame-work, which is made in the form shown in the different figures, and of metals of sufficient size and strength to stand the strains to which it will be subjected. B and B' are swivel hooks on this frame. Their use is evident. D is the wheel part of the endless screw. Fastened rigidly to the wheel part D are the two chain-pulleys H and H', all of which revolve on the shaft or axle I I'. The chain-pulley H is of a larger diameter than the chain-pulley H'.

In chain-wheel H, *b b b*, and in chain-wheel H' *a a a*, are sprockets, to keep the chain from slipping or sliding. P is the drive-pulley, the axle C of which has the screw part of the endless screw, as shown in Fig. 2, the said axle C having bearings in the parts A^3 and A^3 of the said frame-work, which parts are fastened to the other part by the screws *n n*.

In Fig. 2, *t* and *s* are teeth on the wheel, and *r* and *d* threads of screw, showing how they engage each other.

The drive-pulley P is fastened to the axle C by the hub E and screw J. This drive-pulley P has sprockets *x*, *y*, and *z* in its concave rim, for the purpose of preventing the endless rope or chain used thereon from slipping or sliding.

In Fig. 3, M is the sheave of the snatch-block; *p*, the axle of the same. T, T', and T² are guards. S is a hook in the same.

In the construction of all of the parts of my apparatus I make use of materials of such a size and strength as will stand all the strains to which the apparatus will be subjected in the use for which it is intended.

Having thus described the construction of my apparatus, I will now proceed to describe its use and operation.

The frame-work is suitably suspended by the swivel-hook B'. Over the chain-pulleys H and H' is placed the chain, as shown in Fig. 3. R and R' is the chain. This chain then passes under the sheave M, and the weight to be raised is connected with the hook S. It will be noticed that the chain R passes over the larger

chain-pulley H on a different side than the chain R' does on the smaller chain-pulley H', so that the chain R' unwinds while the chain R winds up, and vice versa. The chain R and R' can be made endless.

It will thus be seen that a differential motion is produced, and that comparatively little power is required to turn the pulley P, as the thrust on the screw on the axle C is only slight.

It will readily be further seen that the screw on the axle C, when turned by the pulley P, imparts motion to the wheel part D; but the wheel part D cannot in any way impart motion to the screw on the axle C, from which it is plain that the apparatus is self-sustaining, and the weight must remain suspended at any point desired, and cannot run down.

It will be seen that when the chain is put on the chain-pulleys H and H', as shown in Fig. 3, the weight is raised very slowly; but when greater speed is required, with a corresponding loss of power, I put the chains R and R' on the chain-pulleys H and H', both on the same side, so that they both wind up, as shown by the arrows in Fig. 1; but when put on in this way power is exchanged for space and time. The chain R can be put, if desired, on only one of the chain-pulleys, as H, the other end being put on the hook B; or the said other end may be hitched direct to the weight to be raised.

It will be readily seen that the important feature of my invention is the endless screw with the chain-pulleys fastened rigidly to the wheel part of the said endless screw, and that the said chain-pulleys H and H' can be made to vary greater in diameter than the sheaves in the ordinary differential pulley, for the reason that the screw part of the said endless screw makes my apparatus absolutely self-sustaining, and it cannot run down; and, in addition, I get all the advantages of the power produced by the said endless screw.

It will be further seen that where great power is not required I can dispense with one of the said chain-pulleys and let the chain pass over the other one, and thus form a self-sustaining hoisting apparatus, which will be found cheap and convenient in many places where great

power is not required. Where very great power is required, and there may be danger of tearing the teeth off the wheel part D or the thread of the screw part on the axle C, I make use of two endless screws, connected together by suitable spur-gearing, the wheel parts of the said endless screws being where the chain-pulleys H and H' now are, and next to A² and A⁶, and the said chain-pulleys being side by side between the said wheel parts of the said endless screws.

In the form and construction of the framework A¹, A², A³, A⁴, A⁵, and A⁶ the form shown need not be exactly followed; but the framework must be made strongly and substantially, with proportions adapted to the use for which it is intended.

I am aware that differential-pulleys operated by an endless screw have heretofore been employed in hoisting apparatus, and this I do not claim broadly; but

What I claim is—

1. In combination with the wheel part of the endless screw, the differential pulleys mounted at each side thereof, and the supporting-frame of the screw part journaled in detachable bearings A³, the whole constructed and arranged substantially as specified.

2. In a hoisting apparatus, the combination, with the differential pulleys of the wheel part, of two endless screws located one on each side of the pulleys and on the same shaft, and two screw parts gearing into said wheel parts and journaled in detachable bearings, substantially as and for the purpose specified.

3. In a hoisting apparatus, the framework A¹, A², A³, A⁴, A⁵, and A⁶, swivel-hooks B and B', substantially as described, in combination with one or more endless screws, the differential pulleys H and H', drive-wheel P, and axle or shaft I I', all substantially in the manner and for the purpose herein shown and specified.

CHAS. E. ALBRO.

Witnesses:

FRANKLIN PIERCE,
H. J. HARRINGTON.