

W. KRUTZSCH.  
Lathe-Head.

No. 201,021.

Patented March 5, 1878.

Fig. 1.

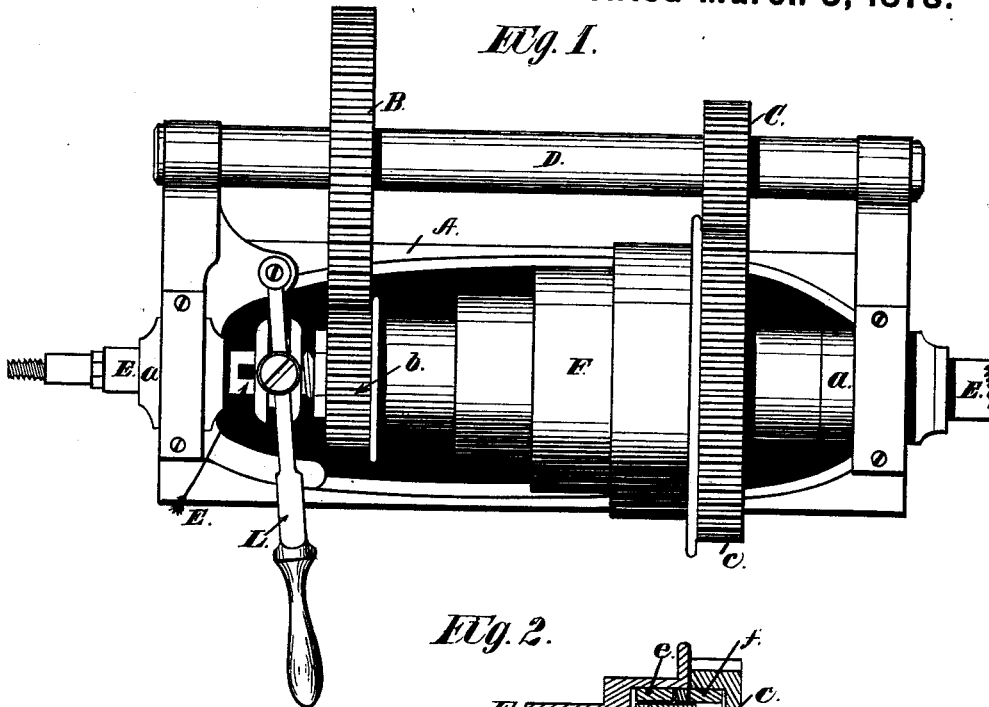

Fig. 2.

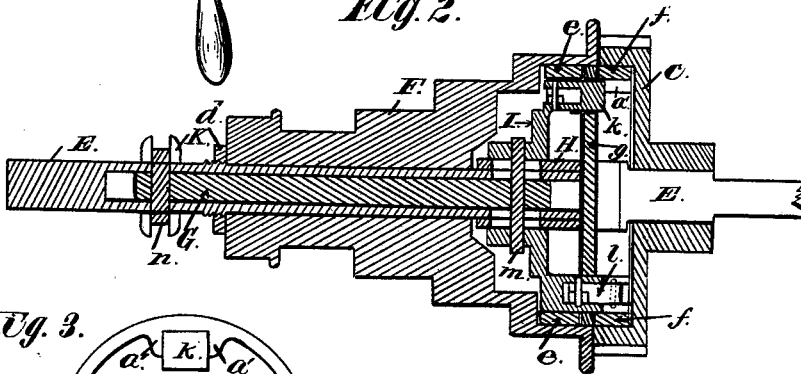

Fig. 3.

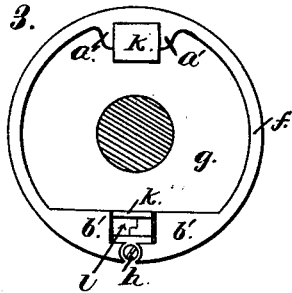
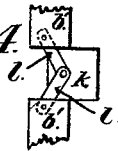

Fig. 4.



Witnesses;  
Chas. M. Peck  
Wm. Ritchie

Inventor;  
William Krutzsch  
by his Atty's.  
Peck & Co.

# UNITED STATES PATENT OFFICE.

WILLIAM KRUTZSCH, OF DAYTON, OHIO, ASSIGNOR TO BUCKEYE IRON  
AND BRASS WORKS, OF SAME PLACE.

## IMPROVEMENT IN LATHE-HEADS.

Specification forming part of Letters Patent No. **201,021**, dated March 5, 1878; application filed  
September 3, 1877.

*To all whom it may concern:*

Be it known that I, WILLIAM KRUTZSCH, of Dayton, in the county of Montgomery and State of Ohio, have invented certain new and useful Improvements in Lathe-Heads; and I do hereby declare the following to be a full, clear, and exact description of the same.

This invention has for its object the production of a metal-working lathe-head in which the construction is such that the speed of the carrying-mandrel can be instantly changed from fast to slow, or vice versa, to suit the kind of work operated on, and without changing or interfering with the speed of the driving pulleys or cone.

My improvement consists in the construction and employment, within the cone, of a double expansible chuck operated by a rod within the mandrel and controlled by a lever, by means of which either the large gear-wheel of the mandrel or the cone may be alternately made fast to the mandrel to regulate its speed, or by which both may be freed and the mandrel stopped without stopping the revolution of the cone, all as will be herewith described.

Figure 1 represents a plan view of my improved lathe-head. Fig. 2 is a central longitudinal sectional view of the mandrel, cone, gear-wheel, and operating devices. Fig. 3 is an end elevation of the expansible chuck. Fig. 4 is a sectional detail view of the expansion-toggle.

A is the frame-work or spindle-head, of the usual or any suitable shape and construction. B and C are the back gear-wheels, mounted upon the shaft D in the usual manner. Upon the mandrel E, which is journaled in the boxes *a*, are the cone F and small gear-wheel *b*, of one piece, and the large gear-wheel *c*. The cone and wheel *c* are loose upon the mandrel, and are held in position by the nut *d* and the box *a*, as shown. The wheels B and *b*, C and *c*, mesh together, as in all lathe-heads.

The interiors of the cone and wheel *c* are hollowed, as seen in Fig. 2, to form a recess, in which the expansible chucks or friction-disks are contained and work. These latter consist of two annular disks, *e* and *f*, arranged upon opposite sides of a disk, *g*, which is keyed upon or forms part of the mandrel E.

By reference to Fig. 3 the construction of one of the rings is clearly seen. On its inner periphery are two diametrical bearings, *a'* and *b'*, and half-way between the latter the ring is cut in two to allow the passage of the screw *h* into the disk *g*, and to permit of its expansion and contraction. The two screws *h* are arranged diametrically and on opposite sides of the disk *g*, and serve as means for attaching the rings to the disk, but do not prevent their expansion.

The mandrel E is hollow, and contains a rod, G, which extends from near the disk *g* to a point some little distance beyond the nut *d*. The mandrel is slotted longitudinally and diametrically at points near the extremities of the rod G, and within the recess of the cone is a collar, H, upon the mandrel, with slots through it corresponding with slots at that portion of the mandrel. Over this fits a second collar, I, from which extend diametrically two arms, *j*, with right-angular projecting pieces *k*, that pass through the disk *g*, and between the lugs *a'* and *b'* of the rings. Pivoted in recesses in the pieces *k* are toggle-levers *l*, Figs. 2, 3, and 4, with their outer ends pivoted in the lugs *b'*.

A key, *m*, passed through the slots in the collar H and the mandrel, connects the collar I to the rod G, and upon the mandrel, over its other slots, is a grooved collar, K, which is also keyed to the rod G by a pin, *n*.

By means of a lever, L, pivoted at *o* upon the frame A, the collar K, carrying the rod G, can be moved to the right or left. As the rod G is moved to the right the pieces *k* pass through the disk *g*, and extend the toggles of the ring *f*, thereby expanding it, and locking it tightly to the inner periphery of the wheel *c*. The mandrel will then receive its motion as follows: The loose cone will drive the wheel B, and the wheel C will drive the wheel *c*, and with it the mandrel. This will be the lowest rate of speed. By shifting the lever L to the extreme left the pieces *k* will be withdrawn, contracting the ring *f*, and freeing it from contact with the wheel *c*, and at the same time expanding the ring *e* until it locks the cone to the mandrel. The wheel *c* is then loose, and the mandrel is driven directly from the cone.

By placing the lever half-way between its extreme points both rings are partially contracted, and both the cone and the wheel *c* are loose, so that the mandrel will not revolve. By this means I can dispense with eccentric back gear, and at the same time the operator can instantly stop or change the speed of the mandrel without reaching over the lathe at the risk of his life or limbs.

Having thus fully described my invention, I claim—

1. The combination, with a hollow mandrel and its contained rod, of the collar I, having right-angular recessed blocks *k*, provided with toggle-levers *l*, for alternately expanding or contracting the rings *e* and *f*, whereby the cone F and gear-wheel *c* are alternately locked to the mandrel, as and for the purpose specified.

2. The combination, with a recessed cone

and gear-wheel upon a lathe-mandrel, of the rings *e* and *f*, constructed and arranged as described, and operated by the toggle-levers *l* in the collar I, whereby they may be respectively and alternately expanded or contracted to connect the cone or gear-wheel to the mandrel, in the manner and for the purpose specified.

3. The herein-described lathe-head, consisting of the frame A, back gear B C, cone F, and gear-wheel *c*, hollow mandrel with its rod G and lever L, collar I, with its toggles *l*, disk *g*, and rings *e f*, the whole being constructed and united substantially as specified.

Witness my hand this 20th day of July, A. D. 1877.

WILLIAM KRUTZSCH.

Witnesses:

CHAS. M. PECK,  
WM. RITCHIE.