

T. LANGHAM.  
Knitting Machine.

No. 201,024.

Patented March 5, 1878.

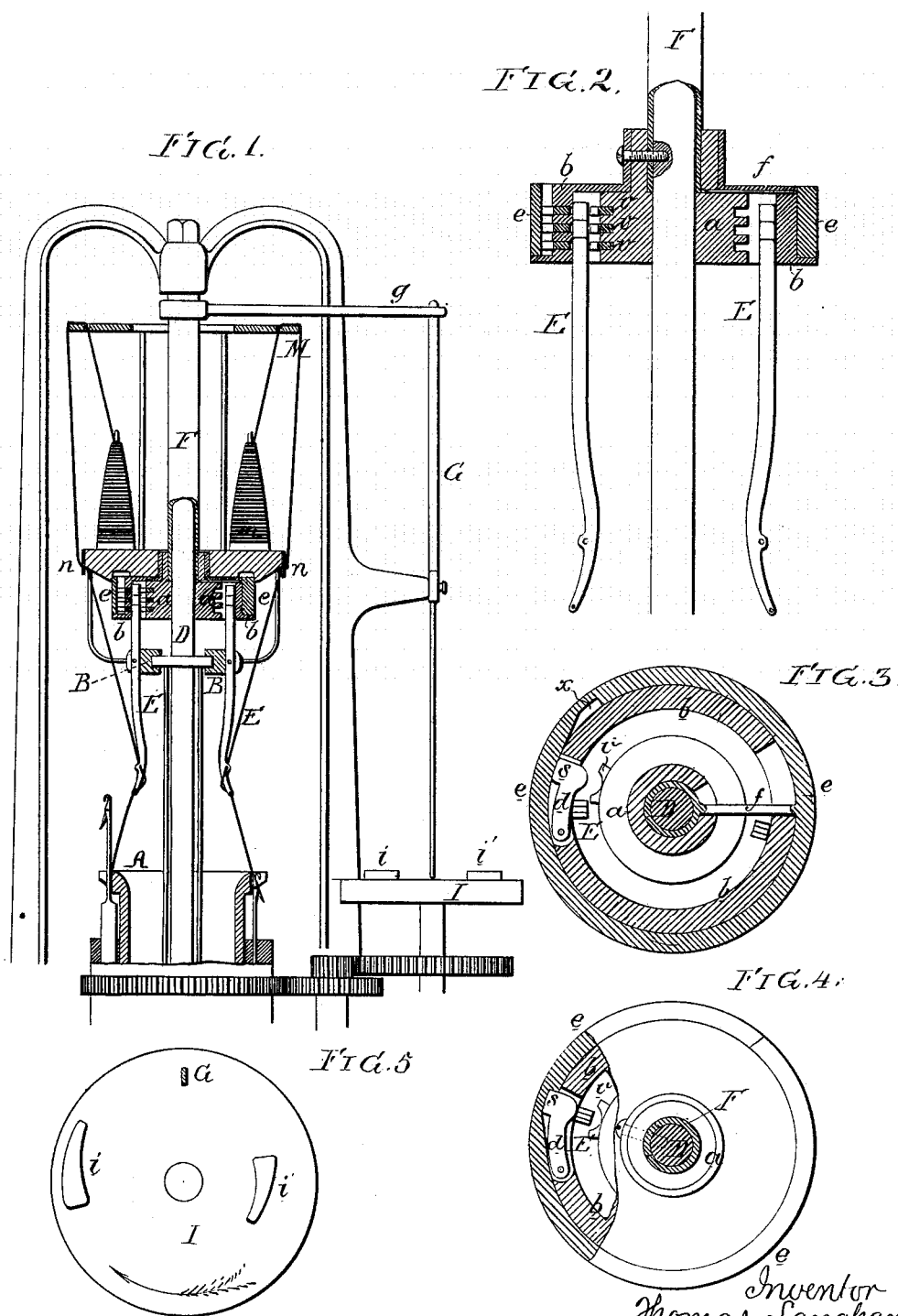

Witnesses, Harry Smith  
John W. Bremer

Inventor  
Thomas Langham  
by his Attorneys  
Howson & Son

# UNITED STATES PATENT OFFICE.

THOMAS LANGHAM, OF ELWOOD, NEW JERSEY.

## IMPROVEMENT IN KNITTING-MACHINES.

Specification forming part of Letters Patent No. 201,024, dated March 5, 1878; application filed January 12, 1878.

*To all whom it may concern:*

Be it known that I, THOMAS LANGHAM, of Elwood, Atlantic county, New Jersey, have invented a new and useful Improvement in Knitting-Machines, of which the following is a specification:

My invention relates to certain improvements in the knitting-machine for which Letters Patent of the United States No. 178,167 were granted to me on the 30th day of May, A. D. 1876, the object of my present improvements being to render automatic the action of the levers which carry the supplementary or figuring threads. This object I attain in the following manner, reference being had to the accompanying drawing, in which—

Figure 1 is a sectional view of the knitting-machine with my improvements applied thereto; Fig. 2, an enlarged vertical section of a portion of the machine; and Figs. 3, 4, and 5, sectional plans.

The above-mentioned patented machine illustrated and described a series of levers arranged adjacent to the needles of an ordinary circular head, and carrying threads, which were at intervals carried by the levers to the front of the needles of the head, and looped around the same, so as to form extra stitches, which appeared upon the face of the fabric in the form of stripes or figures. These levers were operated by cams at suitable intervals; and hitherto, when it was desired to interrupt the formation of the stripe or figure upon the fabric, it was necessary that the machine should be stopped, and the cams so manipulated that they ceased to act upon the levers, which remained quiescent, and laid their threads straight along the back of the fabric.

The same stoppage in the operation of the machine and manipulation of the cams was demanded when it was desired to again commence the formation of stripes or figures. These stoppages and changes of the cams by hand are objectionable, partly on account of the loss of time which they necessarily occasion, but even more so on account of the unevenness of the work which is produced on account of the stoppage of the machine sooner at one time than at another. These objections I overcome in the following manner: Above the circular frame or head A, carrying the needles,

I arrange a ring, B, which embraces the central fixed shaft D, and is attached to the rotating portion of the head, so as to turn with the same. This ring is slotted for the reception of the levers E, which are pivoted to the ring, and extend above and below the same, their lower ends having eyes for the passage of the threads, and their upper ends projecting into the annular space which intervenes between a collar, *a*, secured to the shaft D, and a ring, *b*, secured to said collar.

I have shown in the present instance two sets of levers, E, three levers being comprised in each set. It should be understood, however, that in practice a greater or less number of sets of levers, or of levers in each set, may be employed, as desired.

In the ring *b* are formed, in the present instance, three slots adapted for the reception of three pivoted cams, *d*, the cams being arranged one above the other, and each cam having at the rear a projecting lug, *s*.

The upper ends of the levers E are of unequal lengths, one lever extending to the level of the uppermost cam *d*, the next lever to the middle cam, and the last lever to the lowermost cam only, so that each cam acts upon a separate lever. In practice, instead of having one cam only for each lever of a set, there is a row of cams for each of said levers, the number of rows equaling the number of levers in a set, and the number of cams in each row depending upon the desired character of the pattern to be produced by the supplementary or figuring threads.

Surrounding the ring *b* is a ring, *e*, which is connected by an arm, *f*, to a sleeve, F, embracing the shaft D, the inner face of the ring *e* being furnished with a recess, *x*. In a working machine these recesses will correspond in number to the largest number of cams in any of the rows carried by the ring *b*.

The upper end of the sleeve F is furnished with an arm, *g*, arranged to be acted upon by the upper arm of a vertical lever, G, pivoted to the frame of the machine, the lower arm of this lever projecting into the path of cams *i i'* on a horizontal disk, I, which is operated in any suitable manner from some working part of the machine. One of the cams, *i*, is arranged to move the lever in one direction, while the

other cam moves it in the opposite direction and restores it to its first position.

Above the collar *a* is a disk, *m*, which is supported by arms projecting upward from the ring *B*, and carries a number of spools or bobbins for furnishing thread to the levers *E*, the threads passing through holes in a ring, *M*, above the spools, thence through openings in plates *n* secured to the edge of the disk, and thence to the eyes of the levers.

The operation of the machine is as follows: When it is desired to form stripes or figures upon the fabric, the ring *e* is turned to the position shown in Fig. 3—that is, with its recess out of line with the lugs *s* on the cams *d*. As the ring *B* revolves the upper ends of the levers *E* come in contact with the cams, and as the latter cannot move outward, owing to the resistance of the ring *e*, the said upper ends of the levers are moved inward, and enter recesses formed in plates *v* secured to the collar *a* in line with the cams *d*. The lower ends of the levers are thus thrown outward, so as to wrap their threads around the needles in the manner described in my former patent.

The cams *i* on the disk *I* are so placed that when the stripe or figure has to be discontinued the lever *G* will be so operated as to cause a partial revolution of the sleeve *F* and ring *e*, in order to bring the recess of the latter into line with the lugs *s* on the cams *d*, as shown in Fig. 4. In this case the levers *E*, on coming in contact with the cams *d*, press the latter outward, the levers themselves remaining quiescent, so that their threads are not carried to

the front of the needles, and no striping or figuring stitches are formed.

When the formation of the stripe or figure is to be continued, the other cam on the disk *I* moves the lever *G* in a direction contrary to that in which it was previously moved, so that the parts are again restored to the position shown in Fig. 3.

The movement of the ring *e* is thus rendered entirely automatic, so that no stoppage of the machine occurs when a change in the fabric is made. Moreover, as the changes are made by the machine itself, it follows that the work produced must be perfectly uniform.

I do not desire to confine myself to the exact arrangement shown for effecting the changes in the position of the ring *e*, as other devices might be substituted for the same; but

I claim as my invention—

1. The combination of the levers *E*, the ring *b* and its cams, the recessed ring *e*, and the sleeve *F*, connected to the said ring *e*, all substantially as specified.

2. The combination of the levers *E*, the ring *b* and its cams, and the recessed ring *e* with devices, operated substantially as described, for causing the partial turning of said ring *e*, as set forth.

In testimony whereof I have signed my name to this specification in presence of two subscribing witnesses.

THOMAS LANGHAM.

Witnesses:

JOHN LANGHAM,  
THEO. W. HOLDEN.