

C. H. MORGAN.  
Hydraulic Elevator.

No. 201,037.

Patented March 5, 1878.

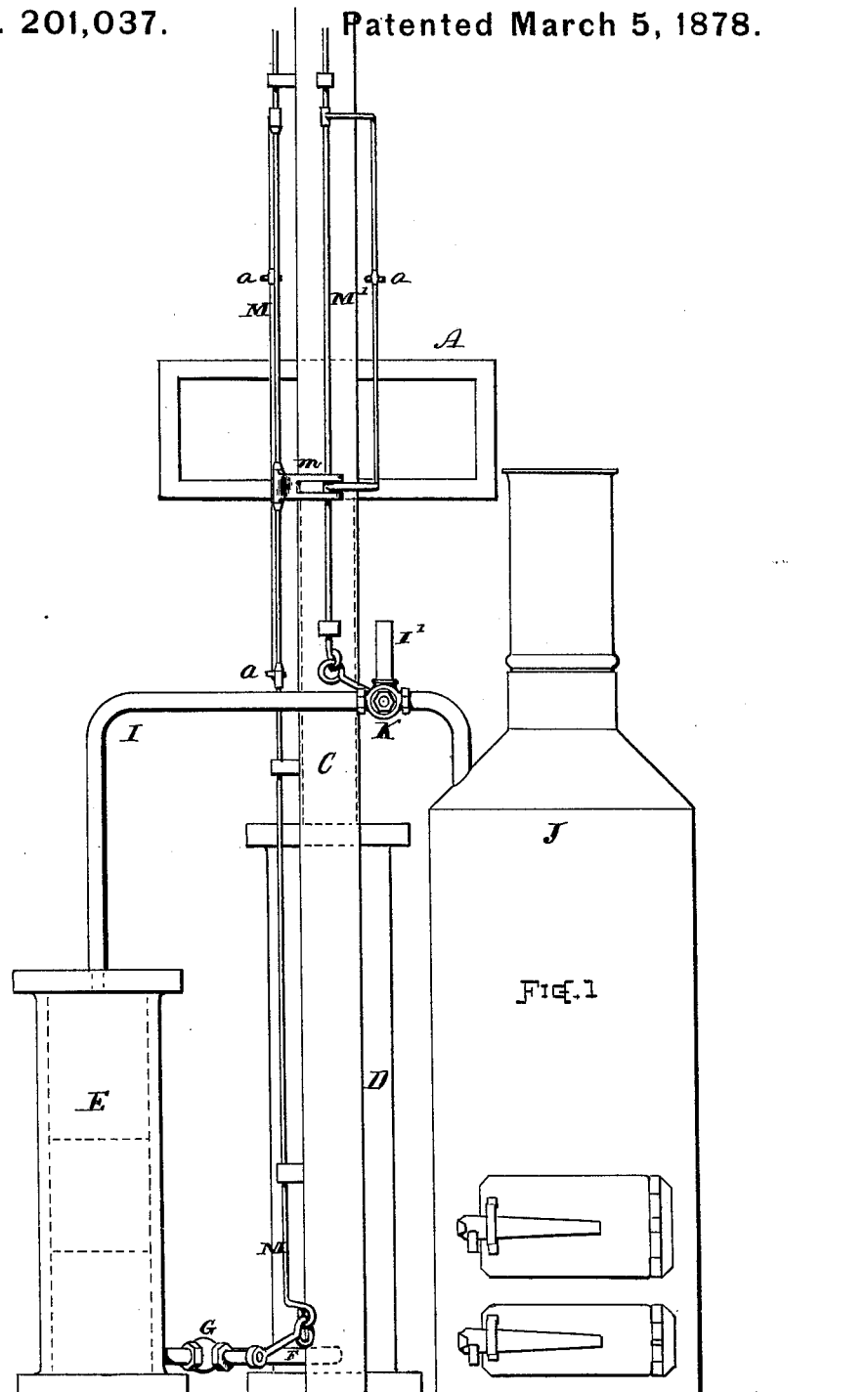

Witnesses

*S. R. Barton*  
*D. C. Barton*

Inventor

*Charles H. Morgan*  
by *Chas. H. Purling*  
*Att'y.*

C. H. MORGAN.  
Hydraulic Elevator.

No. 201,037.

Patented March 5, 1878.

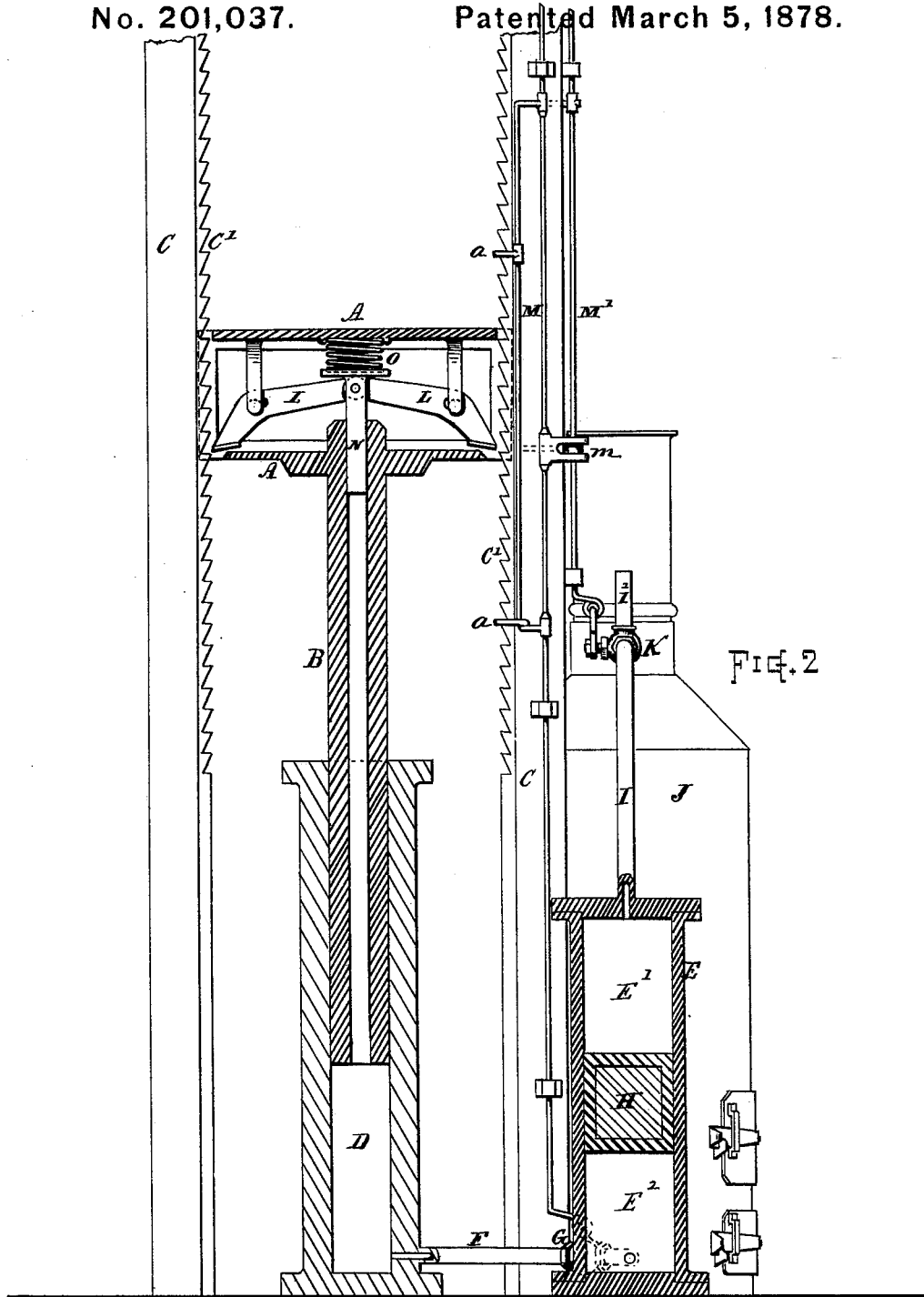

FIG. 2

Witnesses  
*S. M. Barton*  
*S. M. Barton*

Inventor  
*Charles H. Morgan*  
 by *Chas. H. Doolittle*  
*Atty.*

C. H. MORGAN.  
Hydraulic Elevator.

No. 201,037.

Patented March 5, 1878.

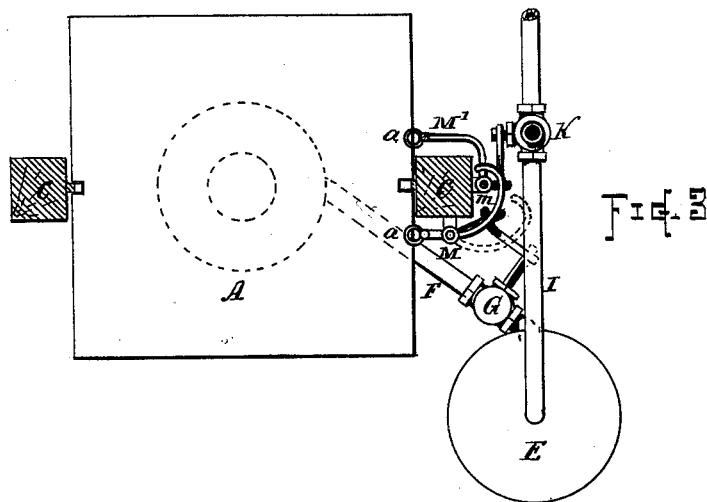

FIG. 3

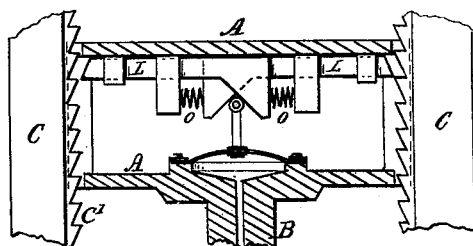

FIG. 4

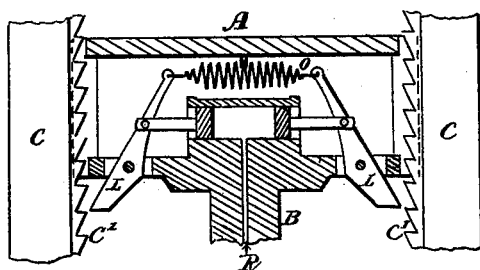

FIG. 5

Witnesses.

*S. R. Barton*  
*S. Ira Barton*

Inventor.

*Charles H. Morgan*  
by *Charles H. Burleigh*  
*Att'y*

# UNITED STATES PATENT OFFICE.

CHARLES H. MORGAN, OF WORCESTER, MASSACHUSETTS.

## IMPROVEMENT IN HYDRAULIC ELEVATORS.

Specification forming part of Letters Patent No. **201,037**, dated March 5, 1878; application filed July 16, 1877.

### *To all whom it may concern:*

Be it known that I, CHARLES H. MORGAN, of the city and county of Worcester, and State of Massachusetts, have invented certain new and useful Improvements in Hydraulic Elevators; and I declare the following to be a description of my said invention sufficiently full, clear, and exact to enable others skilled in the art to which it appertains to make and use the same, reference being had to the accompanying drawings, which form a part of this specification, and in which—

Figure 1 represents a side view of such parts of a hydraulic elevator as are necessary to illustrate the nature of my invention. Fig. 2 represents a part front, part sectional, view of the same, and Fig. 3 represents a plan view of portions of the valve-operating mechanism. Figs. 4 and 5 indicate modifications in the safety-stop mechanism.

One feature of my invention consists in the employment, in a hydraulic-elevator mechanism, of a safety-stop or platform-locking device operated or governed by the pressure of the water in the elevator-cylinder, substantially as hereinafter explained.

Another feature of my invention consists in the employment, in an elevator mechanism operated by hydraulic and steam power, of duplex governing devices and valves, arranged for separate or combined operation, substantially as hereinafter described, for regulating the action of the steam and water, and subjecting their forces to more perfect control from the elevator-platform, and adjusting the power to the desired effect, or adapting it to the amount of work to be performed, as hereinafter explained.

Another feature of my invention consists in the combination, with the steam or reservoir cylinder, of a buoyant or floating piston, as hereinafter described.

Minor features of the invention are explained in the following description, the subject-matter claimed being hereinafter definitely specified.

In the drawings, A denotes the elevator car or platform supported on the upper end of the piston-column B, and arranged to move up and down between the guides C C, in the ordinary manner, by the pressure of water

within the cylinder D. E indicates the reservoir-cylinder, from which the water is forced into cylinder D for elevating the piston B, and into which the water returns when the piston descends.

The cylinders E and D are connected near their lower ends by a channel or pipe, F, which is provided with a stop-cock or valve, G, for closing the passage or regulating the flow of water through, into, and from the cylinder D. The water is forced from the cylinder or reservoir E by steam entering the upper portion E' of said cylinder, above the piston H, through the pipe I, which leads from a suitable steam-supply boiler, J, placed at any convenient position. The steam-pipe I is provided with a stop-cock or valve, K, for shutting off or regulating the flow of steam, and with an escape pipe or nozzle, I', also opened and closed by the same valve K.

The valves G and K are respectively connected for operation to the governing rods or lines M and M', which extend up to the top of the guides C at a convenient position to be operated from the elevator-platform A, or at any height as desired. The governing-lines are provided with a suitable coupling device, m, whereby the two lines M and M' can be connected with each other, so that they operate the valves G K in unison, or be disconnected, so that each line and valve may be operated separately and independently of the other.

The coupling device may, if desired, be arranged so as to be operated from the platform A while in motion. Stop-lugs a a, or other suitable devices such as are commonly used, may be combined with the lines M and M', for engagement with the platform or car A, to close the valves when the car has reached a given height or position.

I do not desire to confine my claim to the particular construction of the governing-lines herein shown for operating the valves G and K, or to the particular devices for coupling said lines to each other, since any other construction effecting similar combined and independent action could be employed without departing from the spirit of my invention.

The piston H is made so as to float on the surface of the water within the cylinder E,

and may be formed of wood or other light material, or as a hollow metallic shell filled with air or buoyant gas. Said piston H separates the steam in the upper chamber E<sup>1</sup> of the cylinder from the water in the lower chamber E<sup>2</sup>, and thus prevents condensation of the steam.

The platform or car A is provided with a safety mechanism for locking it to the ratchets C' on the guides C. This safety mechanism I combine with the piston-column B in such manner that the pressure of the water used within the cylinder D for raising the platform serves to actuate or govern the action of the locking devices. In the present instance the safety mechanism consists of a pair of latch-levers, L, fulcrumed on a portion of the platform-frame, with their outer ends in position to engage the ratchets. The inner ends of said levers L are pivoted to a small piston-rod, N, working into a cylindrical opening in the upper part of the piston-column B, while a spring, O, is arranged in opposition to the piston N for depressing the parts. (See Fig. 2.)

The piston-column B is formed hollow, and while the water is confined in the cylinder D, and supports the weight of the platform A and its load, the pressure, acting on the piston N through the hollow column B, compresses the spring O, and keeps the levers L from locking into the ratchets C'. But in case of the bursting of the cylinder, or any occurrence that would reduce the pressure on the piston N below the adjusted force of the spring O, the levers L are moved downward and outward to engage the ratchets and support the platform.

In lieu of the piston N for actuating or retaining the locking devices, a diaphragm may be employed for utilizing the pressure, as in Fig. 4, or, if desired, an additional or auxiliary cylinder may be arranged on the car, from the interior of which cylinder communication is established with the interior of the main cylinder D by means of a pipe or channel, R, leading through the column B. (See Fig. 5.)

The detail of construction of the locking mechanism may be varied without change in the nature of the invention.

The operation of my improved mechanism is briefly as follows: The valves G and K being opened, steam from the boiler J passes into the reservoir-cylinder E, driving the water from thence into the elevator-cylinder D, where it forces up the piston B and platform A. When the load is comparatively light the valve K may be closed when a part of the distance has been run, and the remainder of the distance be

accomplished by the expansion of the steam in the cylinder E. By closing the valve G the car or platform A is detained at any desired position. To descend or run downward, the valve K is turned so as to permit the steam to escape from the cylinder E through the pipe I', and, the valve G being open, the water flows back into the reservoir-cylinder E.

Among the advantages attained by my invention may be mentioned the great economy of power by the utilization of the expansive force of the steam and adaptation of the power to the load, the perfect control of the car by the duplex action of the governing mechanism, also the permanent locking of the car or platform in position at any reduction of the sustaining force below a given pressure.

Having described my improvements in hydraulic elevators, what I claim therein as new and of my invention, and desire to secure by Letters Patent, is—

1. In a hydraulic elevator, the combination, with the car or platform, of a safety-stop or locking mechanism governed in its action by pressure from the water within the elevator or water-cylinder, and automatically operating to uphold or lock the elevator-car in position when sudden reduction of the ordinary supporting pressure occurs, substantially as hereinbefore set forth.

2. In combination with the cylinder D, platform A, and ratcheted guides C C', the hollow piston-column B, piston N, spring O, and locking-levers L, substantially as and for the purposes set forth.

3. In an elevator mechanism operated by hydraulic and steam power, a duplex governing apparatus the parts of which are arranged for combined or independent action, in combination with valves for regulating the flow of steam and the flow of water into and from the reservoir or intermediate cylinder, substantially as hereinbefore set forth.

4. In combination with the cylinder E and pipes F I, the stop-cocks or valves G and K and governing-rods M M', substantially as and for the purposes set forth.

5. The combination, with the elevator-platform A, piston B, cylinder D, intermediate reservoir-cylinder E, and steam-supply boiler J, of the pipes F I, valves G K, governing-rods M M', and coupling m, substantially as and for the purposes set forth.

CHAS. H. MORGAN.

Witnesses:

CHAS. H. BURLEIGH,  
S. H. CLARY.