

T. B. FOGARTY.
Vapor-Jet Gas-Machines.

No. 201,101.

Patented March 12, 1878.

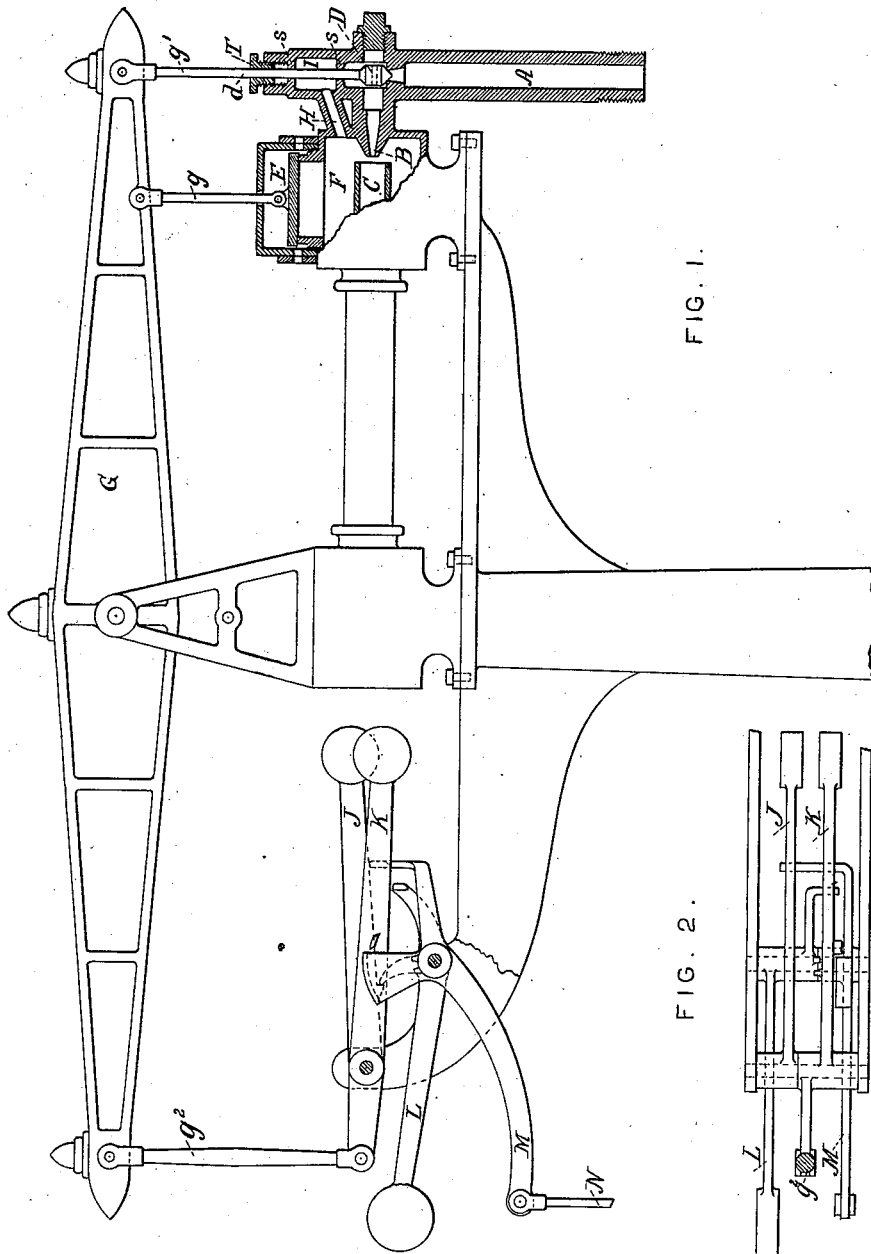

FIG. 1.

FIG. 2.

WITNESSES:

R. A. Vernon.
Walter Pell

Inventor
Thomas B. Fogarty
by his Attorney
Wm. Lemble Hall.

UNITED STATES PATENT OFFICE.

THOMAS B. FOGARTY, OF JERSEY CITY, NEW JERSEY.

IMPROVEMENT IN VAPOR-JET GAS-MACHINES.

Specification forming part of Letters Patent No. **201,101**, dated March 12, 1878; application filed December 20, 1876.

To all whom it may concern:

Be it known that I, THOMAS B. FOGARTY, of Jersey City, in the county of Hudson and State of New Jersey, have invented a new and useful Improvement in Gas-Machines, of which the following is a specification:

The said invention relates to machines for making gas from hydrocarbon vaporized under pressure in a heated retort, and mixed with air by induction, the process being regulated by the motion of the gas-holder consequent upon the consumption of the gas; and the object of the invention is to make the valve-gearing positive in its action, and to remove the valve-stem from the induction-tube, and enable its stem to be effectively packed.

Figure 1 is a side elevation, partly in section, of my said improved valve-gear; and Fig. 2 is a plan of the same.

A is the vapor-tube leading from the retort. B is the vapor or induction jet. C is the induction-tube, placed in front of the induction-jet. D is a double-seated vapor-valve, made to seat itself at both the top and bottom of its stroke. E is the air-valve, by which air is admitted to the chamber F, whence it is drawn into the induction-tube by the inductive force of the vapor escaping from the jet. G is a walking-beam, connected at one end to the valves E and F by the rods g and g^1 , and at the other to the system of actuating-levers by the rod g^2 . H is a tube or chamber, forming a connection between the air-chamber F and a chamber, I, that incloses the stem of the valve D. The system of valve-levers J, K, L, and

M is connected with the gas-holder by the rod N, and is essentially the same as that described in the Patent No. 171,607, issued to me December 28, 1875, from which it differs by operating the valves through the intervention of the beam G.

For the efficient working of the machine, it is necessary that the stem d of the valve D work freely through its guides $s s$, as well as through the stuffing-box T. As the guides cannot be relied on to prevent the escape of gas, and the packing in the stuffing-box may not be sufficient to resist an accidental pressure arising in the retort, I have devised the chamber I and the pipe or chamber H, forming a communication between that and the air-chamber F, so that any leakage of vapor from the valve will pass into the chamber F through the pipe H, and thence to the gas-holder.

It is evident that while the chamber I is kept in communication with the gas-holder by the pipe H the pressure in it can never rise higher than that in the gas-holder.

I claim as my invention in automatically-working gas-machines, and desire to secure by Letters Patent—

1. The chamber, I placed between the stuffing-box T and the vapor-valve D.
2. The combination of the chamber I with the pipe H and the air-chamber F, substantially as described.

THOS. B. FOGARTY.

Witnesses:

WALTER PELL,
WM. KEMBLE HALL.