

F. H. TRENHOLM.  
Cart-Body.

No. 201,209

Patented March 12, 1878.

Fig. 1.

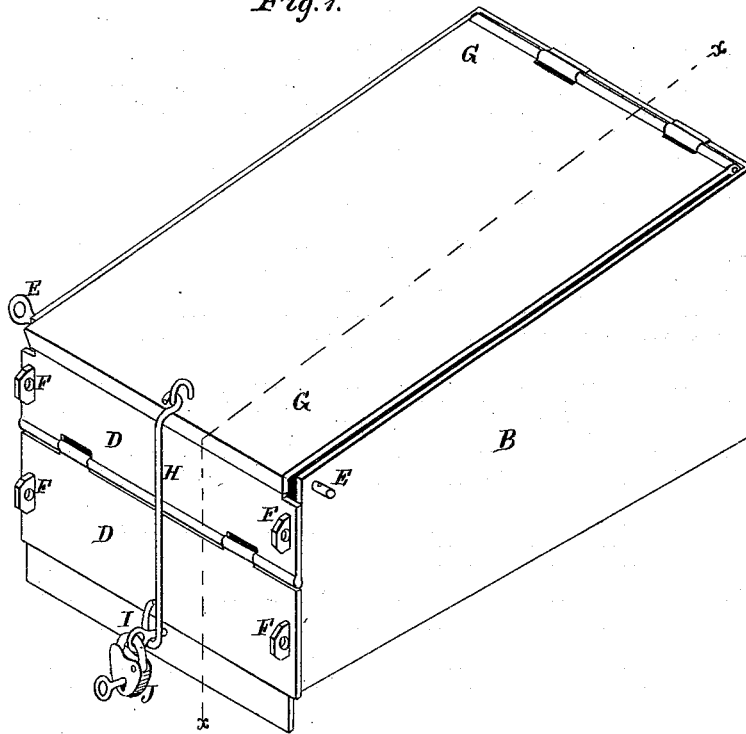
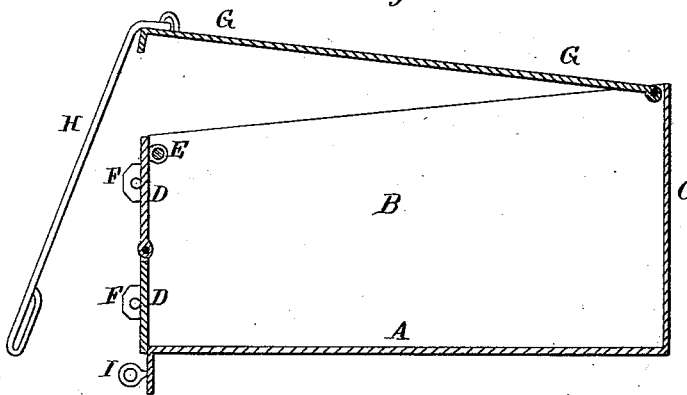

Fig. 2.



WITNESSES:

Henry N. Miller  
C. Sedgwick

INVENTOR:

F. H. Trenholm  
BY Munn & Co.

ATTORNEYS.

# UNITED STATES PATENT OFFICE.

FRANCIS H. TRENHOLM, OF CHARLESTON, SOUTH CAROLINA.

## IMPROVEMENT IN CART-BODIES.

Specification forming part of Letters Patent No. **201,209**, dated March 12, 1878; application filed February 19, 1878.

*To all whom it may concern:*

Be it known that I, FRANCIS H. TRENHOLM, of the city and county of Charleston, and State of South Carolina, have invented a new and useful Improvement in Cart-Bodies, of which the following is a specification:

Figure 1 is a perspective view of one of my improved cart-bodies. Fig. 2 is a vertical longitudinal section of the same, taken through the line *x x*, Fig. 1.

Similar letters of reference indicate corresponding parts.

The object of this invention is to furnish improved cart-bodies for carrying coal, fruit, and other substances, which shall be so constructed as to prevent the driver or others from abstracting any of the contents, and which at the same time shall be simple in construction and convenient in use.

The invention consists in a cart-body provided with a tail-board made in two parts, hinged to each other at their adjacent edges, hinged at its upper edge to the rear upper corners of the side-boards, and having its ends slotted, to receive the lugs by which it is secured to the said side-boards; and in a cart-body provided with a cover hinged at its forward end to the upper edge of the front end-board, and provided with a hinged rod, bar, or hasp, to pass down across the tail-board, and be locked to an eye or staple below the bottom of the said cart-body, as hereinafter fully described.

A represents the bottom, B the sides, and C the forward end, of a cart-body, about the construction of which parts there is nothing new. D is the tail-board, which is made in two parts, hinged to each other at their adjacent edges. The upper edge of the tail-board D is hinged to a rod, E, which passes through holes in the upper rear corners of the side-boards B, and is detachably secured in place by a key or other convenient means. In the ends of the parts of the tail-board D are formed cross-slots to receive the lugs F, attached to the rear ends of the sides B. The lugs F have holes formed through them, through which rods or pins are passed at the outer side of the tail-board.

With this construction the lower part of the tail-board D may be released and turned up, or the upper part may be released and turned down, or both parts may be released, and the said tail-board allowed to swing upon the rod E, or detached, as circumstances may require.

The cart-body is provided with a cover, G, which is hinged at its forward end to the upper edge of the forward end C of the cart-body, so that its rear end can be raised when required. To the rear end of the cover G is hinged a rod, bar, or hasp, H, which has a loop or slot formed in its lower end to receive an eyebolt or staple, I, attached to a cross-bar or other support below the rear end of the bottom A.

The rod, bar, or hasp H is secured in place upon the eyebolt or staple I by a padlock, J. The bar, rod, or hasp H thus fastens both the cover G and the tail-board D, so that they cannot be opened to abstract any of the contents of the cart-body without breaking into the said cart-body.

In using the cart, the design is for the party sending the load to lock the cart-body, seal up the key in an envelope having a receipt for the load written or printed upon its outer side, and deliver the sealed envelope to the driver. When the driver reaches his destination he delivers the sealed envelope to the party receiving the load, who opens the envelope, takes out the key, hands it to the driver, and sees him unlock the cart-body and deliver the load. He then signs the receipt and delivers it to the driver, who takes it and the key back to the party sending the load.

With this arrangement it will be impossible for the driver or others to abstract part of a load while taking it to its destination.

Having thus described my invention, I claim as new and desire to secure by Letters Patent—

1. A cart-body provided with a tail-board, D, made in two parts, hinged to each other at their adjacent edges, hinged at its upper edge to the rear upper corners of the side-boards B, and having its ends slotted to receive the lugs F, by which it is secured to the said side-

boards, substantially as herein shown and described.

2. A cart-body provided with a cover, G, hinged at its forward end to the upper edge of the front-end-board C, and provided with a hinged rod, bar, or hasp, H, to pass down across the tail-board D, and be locked to an

eye or staple, I, below the bottom of the said cart-body, substantially as herein shown and described.

FRANCIS H. TRENHOLM.

Witnesses:

JOHN E. PHILLIPS,

SHAND SMITH.